

Directional seat valves, direct-operated, with solenoid actuation

(Area of application according to technical rules EAC TR CU 012/2011,
explosion protection marking: 2Ex e mc IIC T4 Gc X)

Type SED6 ..1X/...XE...SO710



Operating instructions
RE 22049-XE-710-B/02.20

Replaces: 11.15
Document no.: RA83517207_AB
English

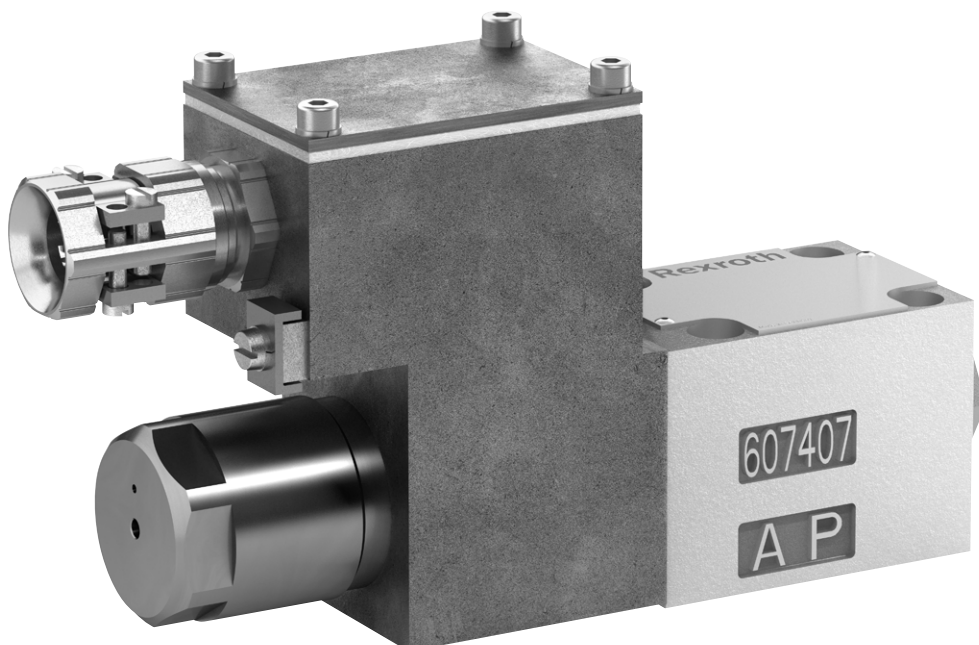

The data specified serves to describe the product. If information on the use of the product is given, it is only to be regarded as application examples and recommendations. Catalog information does not constitute warranted properties. The information given does not release the user from the obligation of own judgment and verification. Our products are subject to a natural process of wear and aging.

© All rights with Bosch Rexroth AG, also in case of applications for industrial property protection. It may not be reproduced or given to third parties without consent of Bosch Rexroth AG.

The cover shows an example configuration. The product supplied may therefore differ from the figure shown.

The original operating instructions were prepared in German.

Contents

1	About this documentation	5
1.1	Validity of the documentation	5
1.2	Required and amending documentation	5
1.3	Representation of information	5
2	Safety instructions	7
2.1	General information on this chapter	7
2.2	Intended use	7
2.3	Improper use	8
2.4	Qualification of personnel	8
2.5	General safety instructions	9
2.6	Product-specific safety instructions	10
2.7	Notices on the valve use	12
2.8	Personal protective equipment	12
2.9	Obligations of the machine end-user	13
3	General information on damage to property and damage to product	14
4	Scope of delivery	15
5	Product information	15
5.1	Product identification	16
6	Transport and storage	17
6.1	Valve transport	17
6.2	Storing the hydraulic valve	18
7	Assembly	19
7.1	Unpacking	19
7.2	Changes to the surface protection of the valve	19
7.3	Installation conditions	20
7.4	Prior to assembly	20
7.5	Required tools	21
7.6	Required accessories	21
7.7	Assembling the valve	22
8	Commissioning	30
9	Operation	32
9.1	General information	32
9.2	Operating the manual override	32
10	Maintenance and repair	33
10.1	Cleaning and care	33
10.2	Inspection and maintenance	34
10.3	Maintenance schedule	35
10.4	Repair	35
10.5	Rectifying external leakages	36
10.6	Spare parts	36
11	Disassembly and removal	37
12	Disposal	38
12.1	Environmental protection	38
12.2	Return to Bosch Rexroth AG	38
12.3	Packaging	38
12.4	Materials used	38

12.5	Recycling	39
13	Extension and modification	39
14	Troubleshooting	39
14.1	How to proceed for troubleshooting	39
15	Technical data	40
16	Appendix	41
16.1	List of addresses	41
16.2	Certificate according to technical rules EAC TR CU 012/2011 (excerpt)	42
17	Index	45

1 About this documentation

1.1 Validity of the documentation

This documentation applies to the following products:

- SED6..1X/...XE...SO710

This documentation is intended for assemblers, operators, service engineers, system end-users, machine and system manufacturers.

This documentation contains important information on the safe and proper assembly, transport, commissioning, operation, use, maintenance, disassembly and simple troubleshooting of the product.

- ▶ You should read this documentation thoroughly and in particular chapter 2 "Safety instructions" and chapter 3 "General information on damage to property and damage to product", before working with the product.



The documentation version with which the product was supplied is valid.

1.2 Required and amending documentation



- ▶ The product may not be commissioned until you have been provided with the documentation marked with the book symbol  and you have understood and observed it.

Table 1: Required and amending documentation

Title	Document number	Document type
 Directional seat valves, direct operated, with solenoid actuation	22049-XE-710	Data sheet
 General product information on hydraulic products	07008	Data sheet
Certificate according to technical rules EAC TR CU 012/2011	Document	see chapter 16.2

1.3 Representation of information

Uniform safety instructions, symbols, terms and abbreviations are used to ensure quick and safe working with the product using this documentation. For a better understanding, they are explained in the following sections.

1.3.1 Safety instructions



In this documentation, safety instructions are included in chapter 2.6 "Product-specific safety instructions" and in chapter 3 "General information on damage to property and damage to product" and whenever a sequence of actions or instructions is explained which bear the danger of personal injury or damage to property. The hazard avoidance measures described must be observed.

Safety instructions are structured as follows:

 SIGNAL WORD
<p>Type and source of danger! Consequences in case of non-compliance</p> <ul style="list-style-type: none"> ▶ Hazard avoidance measures ▶ <Enumeration>

- **Warning sign:** draws attention to the danger
- **Signal word:** identifies the degree of danger
- **Type and source of danger!:** specifies the type and source of danger
- **Consequences:** describes the consequences in case of non-compliance
- **Precaution:** specifies how the danger can be prevented

Table 2: Risk classes according to ANSI Z535.6

Warning sign, signal word	Meaning
 DANGER	Indicates a dangerous situation which will cause death or severe injury if not avoided.
 WARNING	Indicates a dangerous situation which may cause death or severe injury if not avoided.
 CAUTION	Indicates a dangerous situation which may cause minor or medium personal injury if not avoided.
NOTICE	Damage to property: The product or the environment could be damaged.

1.3.2 Symbols

The following symbols indicate notices which are not safety-relevant but increase the comprehensibility of the documentation.

Table 3: Meaning of the symbols

Symbol	Meaning
	If this information is not observed, the product cannot be used and/or operated optimally.
▶	Individual, independent action
1.	Numbered instruction: The numbers indicate that the actions must be carried out one after the other.
2.	
3.	

1.3.3 Abbreviations

The following abbreviations are used in this documentation:

Table 4: Abbreviations

Abbreviation	Meaning
EN	European Standard
ISO	International Organization for Standardization
IEC	International Electrotechnical Commission

Abbreviation	Meaning
RE	Rexroth document in English language
IP	Ingress protection class of electric operating equipment
A, B	Hydraulic connections (actuators)
T	Hydraulic connection (tank)
P	Hydraulic connection (pump)
ANSI	American National Standards Institute
EAC	<i>Eurasian Conformity</i>
TR	Technical rules of the Eurasian Economic Union (EAEU)

2 Safety instructions

2.1 General information on this chapter

The product has been manufactured according to the generally accepted codes of practice. However, there is still the danger of personal injury and damage to property if you do not observe this chapter and the safety instructions in this documentation.

- ▶ Read this documentation completely and thoroughly before working with the product.
- ▶ Keep this documentation in a location where it is accessible to all users at all times.
- ▶ Always include the required documentation when you pass the product on to third parties.

2.2 Intended use

The product is a hydraulic component.

You may use the product as follows:

- as direct operated directional seat valve with solenoid actuation for intended use in explosive atmospheres.

The product is intended for professional use only; private use is excluded.

Intended use includes having read and understood this documentation completely, especially chapter 2 "Safety instructions".

The valve is designed and constructed for the control of oil flows. It complies with the requirements of technical rules EAC TR CU 012/2011.

Information on the type of protection can be found in "*Data sheet 22049-XE-710*" under "*Information on explosion protection*" and on the name plate of the valve.

The valve may only be operated in a technically perfect condition and used as described in these operating instructions. The connection conditions, application conditions and performance data defined in these operating instructions must not be changed.

If you intend to use the valve with other connection, application or performance data than those defined by Bosch Rexroth AG in these operating instructions, please contact Bosch Rexroth AG beforehand. The valve must not be used with other connection, application and performance data than the data defined in these operating instructions without the written approval by Bosch Rexroth AG.

2.3 Improper use

Any use deviating from the intended use is improper and thus not admissible. The installation or use of inappropriate products in safety-relevant applications could result in unintended operating states when being used which in turn could cause personal injuries and/or damage to property. Therefore, please only use a product for safety-relevant applications if this use is expressly specified and permitted in the documentation of the product. For example, in explosion-protected areas or in safety-related control components (functional safety).

Improper use of the product includes:

- Faulty assembly
- Incorrect transport
- Lack of cleanliness during storage and assembly
- Incorrect installation
- Use of inappropriate/non-admissible hydraulic fluids
- Non-compliance with the specified performance limits

Changes are only permitted according to chapter 13 "Extension and modification". Bosch Rexroth AG does not assume any liability for damage caused by improper use. The user assumes all risks involved with improper use.

2.4 Qualification of personnel

The activities described in this documentation require basic knowledge of mechanics, electrics, hydraulics, pneumatics as well as knowledge of the appropriate technical terms. For transporting and handling the product, additional knowledge of how to handle lifting gear and the necessary attachment devices is required. In order to ensure safe use, these activities may only be carried out by an expert in the respective field or an instructed person under the direction and supervision of an expert.

Experts are those who are able to recognize potential dangers and apply the appropriate safety measures due to their professional training, knowledge and experience, as well as their understanding of the relevant conditions pertaining to the work to be undertaken. An expert must observe the relevant specific professional rules and have the necessary expert knowledge.

For example, for hydraulic products, the term expert knowledge refers to the following:

- Reading and completely understanding hydraulic schemes,
- In particular, completely understanding the correlations regarding the safety equipment and
- Knowledge of the function and set-up of hydraulic components.

**Qualification of personnel
for the installation and
commissioning of valves in
explosion-proof areas**

Personnel shall be qualified as follows to the extent necessary to fulfill their tasks:

- Understanding of the general principles of explosion protection, protection classes and device identification
- Understanding of the corresponding aspects affecting the protection concept
- Understanding of the contents of certificates and relevant parts of this standard
- General understanding of the test, maintenance and repair requirements from IEC 60079-17
- Familiarity with the specific methods to be used for selection and construction of devices referenced in this standard
- Understanding of the additional importance of work authorization systems and safe electrical isolation with regards to explosion protection



Bosch Rexroth offers measures supporting training in specific fields.

Please find an overview of the training contents on the Internet at:

<http://www.boschrexroth.de/didactic>

2.5 General safety instructions

- Observe the valid regulations on accident prevention and environmental protection.
- Observe the safety regulations and provisions of the country in which the product is used/applied.
- Only use Bosch Rexroth products in a technically perfect condition.
- Observe all notes on the product.
- Persons assembling, operating, disassembling or maintaining Bosch Rexroth products must not be under the influence of alcohol, other drugs or medications influencing the ability to react.
- Only use original Bosch Rexroth accessories and spare parts in order to prevent any hazard to persons due to unsuitable spare parts.
- Comply with the technical data and environmental conditions specified in the product documentation.
- The installation or use of inappropriate products in safety-relevant applications could result in unintended operating states when being used which in turn could cause personal injuries and/or damage to property. Therefore, only use a product for safety-relevant applications if this use is expressly specified and permitted in the documentation of the product, e.g. in explosion protection zones or in safety-related parts of control systems (functional safety).
- Do not commission the product until you can be sure that the end product (for example a machine or system) in which the Bosch Rexroth products are installed complies with the country-specific provisions, safety regulations and standards of the application.

2.6 Product-specific safety instructions

The following safety instructions apply to chapters 6 to 14.



WARNING

Explosion hazard due to ignitable atmosphere during all work on the valve!

During all work on the valve (assembly, disassembly etc.), an explosive atmosphere must be avoided! Otherwise, an ignition may be triggered which may lead to an explosion.

- ▶ Before working at the valve, make sure that no explosive atmosphere can occur during the work.

Electrostatic charging!

Immediate opening of the terminal box after shut-off of the power supply leads to electric charging and may be an inadmissible source of ignition resulting in an explosion hazard.

- ▶ After having switched off the power supply, you must wait 30 minutes before opening the cover of the terminal box.

Easily inflammable liquid!

In connection with an explosive atmosphere or other heat sources, the use of fluids (e.g. hydraulic fluid, coolants etc.) may lead to explosions.

- ▶ Only use the valve in the intended explosion protection area.
- ▶ The ignition temperature of the liquid used must be 50 K higher than the maximum surface temperature.
- ▶ The self-ignition temperature of the liquids used must be > 320 °C.

Exceedance of the maximum temperatures!

The use of the valve outside the approved temperature ranges may lead to functional failures like overheating of the valve solenoid. Explosion protection is therefore no longer ensured.

- ▶ Only use the valve within the intended environmental and hydraulic fluid temperature range.

Valve solenoid has hot surface!

Risk of burning!

- ▶ Provide a suitable touch guard.
- ▶ During operation, only touch the valve solenoid with heat-protective gloves. Allow the valve solenoid to cool down to room temperature before touching it directly with your hands during maintenance works.

 **WARNING****Pressurized system parts and leaking hydraulic fluid!**

When working at hydraulic systems with stored energy (accumulator or cylinders working under gravity), valves may even be pressurized after switching off the pressure supply. During assembly and disassembly works, the valve or parts may be ejected and cause personal injury and/or damage to property. Furthermore, there is the danger of severe injury caused by a powerful leaking hydraulic fluid jet.

- ▶ Ensure before working at the hydraulic product that the hydraulic system is depressurized and the electrical control de-energized.
- ▶ Completely unload the pressure at machines and systems before working at the valve.

Non-compliance with functional safety!

The valve controls movements in machines or systems. In case of mechanical and electric faults, e.g. failure of the energy supply, persons may be caught by the system, kicked away or bruised.

- ▶ During set-up of your circuit, observe functional safety e.g. according to ISO 13849.

Penetrating water and humidity!

In case of use in humid or wet environments, water or humidity may penetrate electrical connections or the valve electronics. This may cause malfunctions at the valve and unexpected movements in the hydraulic system, which may result in personal injury and damage to property.

- ▶ Only use the valve within the intended IP protection class or lower.
- ▶ Before the assembly, ensure that all seals and caps of the plug-in connections are tight and intact.

CAUTION

Contaminated hydraulic fluid!

Contamination in the hydraulic fluid may cause functional failures e.g. jamming or blocking of nozzles of the valve. In the worst case, this may result in unexpected system movements and thus constitute a risk of injury for persons.

- ▶ Ensure an adequate hydraulic fluid cleanliness according to the details in the data sheet over the entire operating range.

Leakage in case of incorrect working temperatures!

Use of the valve outside the approved temperature range may lead to permanent leakage at the valves. Thus, hydraulic fluid in the form of a leaking hydraulic fluid jet may injure persons, lead to damage to property and endanger the environment.

- ▶ Only use the valve within the intended environmental and hydraulic fluid temperature range.
- ▶ In case of leakage, immediately exchange damaged seal rings or the valve.

Corrosion!

The valve described features surface protection (see "*Data sheet 22049-XE-710*"). Use of the valve in humid environments still holds the danger of corrosion on the valve and on the valve mounting screws and thus a reduction of the preload force of the screw connection. To prevent the valve from becoming loose and causing a risk of injury:

- ▶ Exchange the valves with corrosion damages as soon as possible.
- ▶ Regularly check the surface protection on the valve and the valve mounting screws.



Contact with salt water leads to increased corrosion on the valve. This can lead to chemical corrosion of individual valve components. Therefore, take suitable corrosion protection measures.

2.7 Notices on the valve use

- ▶ The valve must always be filled with hydraulic fluid.
- ▶ To ensure proper functioning, the valve must be vented.
- ▶ Pressure peaks in the joint return line of more than one valve may cause an unintended movement of the control spool and thus unintended switching processes. We recommend using separate return lines.

2.8 Personal protective equipment

The machine end-user must provide the personal protective equipment (such as gloves, working shoes, safety goggles, working clothes, etc...).

2.9 Obligations of the machine end-user

The machine end-user is obliged to check in the order confirmation whether the delivered valve corresponds to the required area of application.

The end-user of the Bosch Rexroth valve is responsible that

- the valve is only being used according to the intended use as defined in these operating instructions.
- the valve is only stored, operated and maintained according to the technical data, operating and environmental conditions indicated in "*Data sheet 22049-XE-710*", in particular that the limit values indicated in "*Data sheet 22049-XE-710*" are not exceeded.
- the applicable provisions, rules and directives on explosion protection are being complied with.
- the operating personnel are instructed at regular intervals.
- a danger zone is marked, if required.
- the safety measures for their specific area of application of the valve are complied with.

3 General information on damage to property and damage to product

The warranty only applies to the delivered configuration.

- The claim to warranty expires in the event of a faulty assembly, commissioning and operation of the product as well as unintended use and/or improper handling.
- The following safety instructions apply to chapters 6 to 14.

NOTICE

Inadmissible mechanical load!

Impact or shock forces on the valve may damage or even destroy it.

- ▶ Never use the valve as handle or step. Do not place/put any objects on top of it.

Dirt and foreign particles in the valve!

Penetrating dirt and foreign particles in the valve lead to wear and malfunctions. The safe function of the valve can no longer be ensured.

- ▶ During installation, ensure utmost cleanliness in order to prevent foreign particles, such as welding beads or metal chips, from getting into the hydraulic lines.
- ▶ Before commissioning, ensure that all hydraulic connections are tight and that all seals and caps of the plug-in connections are correctly installed and undamaged.
- ▶ Do not use linting fabric for cleaning.
- ▶ Ensure that no cleaning agents are able to penetrate the hydraulic system.

Environmentally harmful hydraulic fluid

Leaking hydraulic fluid leads to environmental pollution.

- ▶ Immediately remedy possible leakage.
- ▶ Dispose of the hydraulic fluid in accordance with the currently applicable national regulations in your country.

4 Scope of delivery

The scope of delivery includes:

- Directional seat valve, direct operated, with solenoid actuation
Type SED6..1X/...XE...SO710
 - Product documentation (operating instructions with certificate according to technical rules EAC TR CU 012/2011; data sheet)
- ▶ Check the scope of delivery for completeness.
- ▶ Check the scope of delivery for possible transport damage, see chapter 6 "Transport and storage".



In case of complaints, please contact Bosch Rexroth AG, see chapter 16.1 "List of addresses".

Accessories such as valve subplates and valve mounting screws are not included in the scope of delivery and must be ordered separately. See chapter 7.6 "Required accessories" and 10.6 "Spare parts".

5 Product information



For information on the performance and product description please refer to "Data sheet 22049-XE-710" of your valve.

5.1 Product identification

5.1.1 Information on the name plate and the valve solenoid housing

The meaning of the information on the name plate can be obtained from the correspondingly numbered fields of the following table.

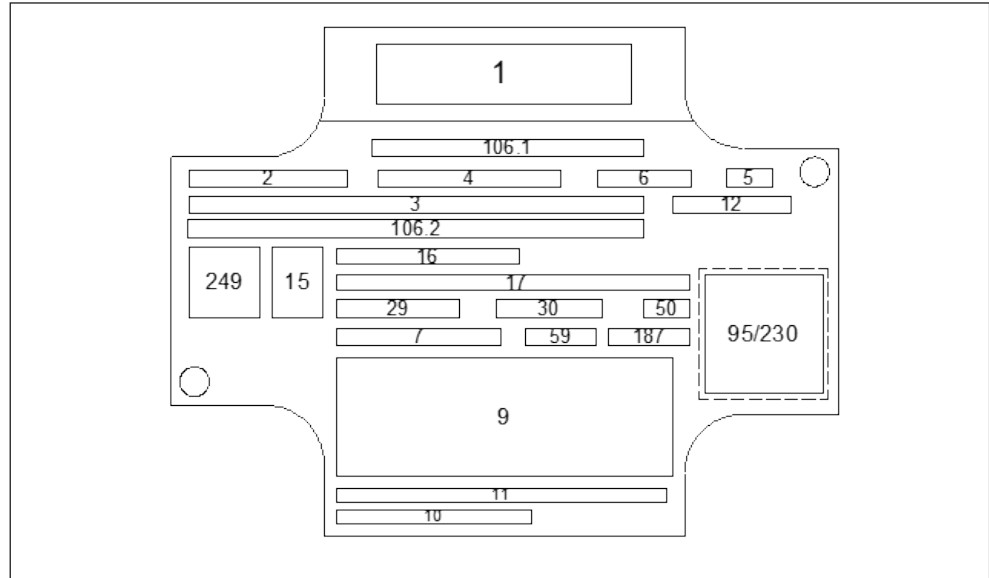

Fig. 1: Name plate for the complete valve

Table 5: Information on the name plate

No.	Type of information
1	Manufacturer's logo
2	Material no. of the valve
3	Type designation complete valve
4	Serial number of the valve
5	Manufacturer's factory number
6	Date of manufacture (year and week)
7	Maximum operating pressure
9	Hydraulic symbol according to ISO 1219
10	Designation of origin
11	Name and address of the manufacturer
12	Customer or production order number
15	Explosion protection mark
16	Marking according to technical rules EAC TR CU 012/2011
17	Other marking according to technical rules EAC TR CU 012/2011
29	Rated voltage
30	Rated current
50	Protection class by housing
59	Graphical pre-fuse symbol
106.1	КЛАПАН ВЗРЫВОЗАЩИЩЕННЫЙ (explosion-protected valve)
106.2	Certification body and approval number
187	Maximum pre-fuse
230	Bosch Rexroth QR code
249	EAC mark

The meaning of the information given on the valve solenoid mounted on the valve is explained in the correspondingly numbered fields of the following table.

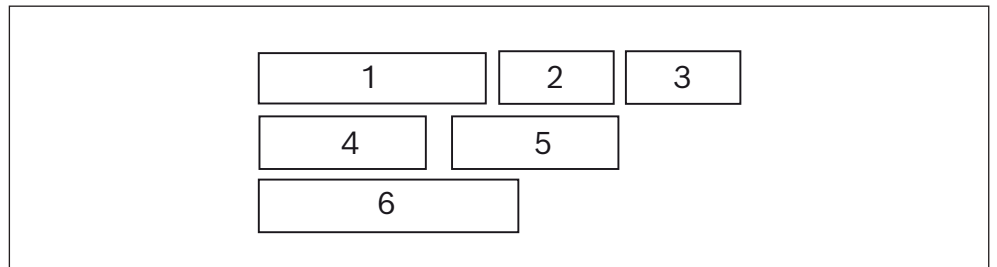

Fig. 2: Solenoid information

Table 6: Solenoid information

No.	Type of information
1	Material number of the valve solenoid
2	Internal code
3	Date of production of the valve solenoid
4	Rated voltage
5	Rated current
6	Serial number of the valve solenoid

6 Transport and storage

6.1 Valve transport

CAUTION

Danger of damage to property and personal injuries!

With improper transport, the valve can fall and lead to damages and/or injuries since the parts are e.g. sharp-edged, oily, instable, loose or bulky.

- ▶ Use the original packaging for transport.
- ▶ Use personal protective equipment (such as gloves, working shoes, safety goggles, working clothes, etc.)
- ▶ Comply with the national laws and regulations regarding occupational health and safety and transport.
- ▶ Do not transport the valve using components with low stability, e.g. solenoids, connectors or cables.

Sharp edges!

Danger of cut injuries!

- ▶ Wear suitable protective equipment for the transport of the safety valve.



Further information regarding transport is available from Bosch Rexroth, see chapter 16.1 "List of addresses".



Report any transport damage to your responsible sales contact person within one week. The addresses of the sales subsidiaries can be found on the Internet on: <http://www.boschrexroth.com/adressen>

6.2 Storing the hydraulic valve

Valves are delivered in a perfect state.



For transporting and storing the product, always observe the environmental conditions specified in "*Data sheet 22049-XE-710*". Improper storage may damage the valve.

Valves can be stored for up to 12 months under the following conditions:

- ▶ Observe the storage temperature range indicated in "*Data sheet 22049-XE-710*".
- ▶ The relative air humidity must not exceed 65 %.
- ▶ The storage rooms must provide 100 % UV protection.
- ▶ No ozone formation may occur near the storage facility.
- ▶ The storage facilities must be free from etching substances and gases.
- ▶ Do not store the valve outdoors but in a well-ventilated room.
- ▶ Protect the valve against humidity, particularly ground humidity. Store the valve on a shelf or on a pallet.
- ▶ Store the valve protected against impacts and sliding and do not stack it.
- ▶ Store the valve in the original packaging or comparable packaging in order to protect it from dust and dirt.
- ▶ All connections at the valve must be closed with cap elements.
- ▶ After opening the transport packaging, it must be closed properly again for storage. Use the original packaging for storage.

Procedure after expiry of the maximum storage time of 12 months

1. Check the complete valve for damages and corrosion prior to installation.
2. In a test run, check the valve for correct function and leak-tightness.



After expiry of the maximum storage time, we recommend having the valve checked by your competent Bosch Rexroth service. In case of questions regarding spare parts, please contact the Bosch Rexroth service responsible for your valve, see chapter 10.6 "Spare parts".

After disassembly

If a dismantled valve is to be stored, it has to be preserved for protection against corrosion for the duration of storage.

Bosch Rexroth recommends the following procedure:

1. Clean the valve; refer to chapter 10.1 "Cleaning and care".
2. Close all connections so that they are airtight.
3. Pack the valve with a desiccant air-tightly in corrosion protection film.
4. Store the valve protected against shocks.

- ▶ In each case, please observe any applicable provisions and laws regarding the handling of substances hazardous to water or to health.

7 Assembly

CAUTION

High pressure!

Risk of injury due to parts shooting out during works at hydraulic accumulators which have not been unloaded.

- ▶ Only work on the valve after the system has been depressurized.
- ▶ Unload accumulators which may have been mounted at the system.
- ▶ Check the system with test pressure according to ISO 4413.
- ▶ Assembly and commissioning may only be carried out by specialists.

7.1 Unpacking

CAUTION

Falling parts!

Risk of injury! If the packaging is opened improperly, parts may fall out and cause injuries or damage of the parts.

- ▶ Put the packaging on level, bearing ground.
- ▶ Only open the packaging from the top.

- ▶ Dispose of the packaging in accordance with the national regulations of your country.

7.2 Changes to the surface protection of the valve

WARNING

Explosion hazard due to modifications to the valve!

In the event of changes to the surface protection of the valve, the following points must be observed:

- ▶ The valve solenoid must not be painted or otherwise coated with non-conductive substances. This leads to a loss of the explosion protection.
- ▶ The valve housing may only be painted according to the provisions of ISO 80079-36, section 6.7; otherwise, explosion protection can no longer be ensured.

7.3 Installation conditions

- ▶ When installing the product, always observe the environmental conditions specified in "*Data sheet 22049-XE-710*".
- ▶ It is imperative to provide for absolute cleanliness. The valve must be protected from dirt during installation. Contamination of the hydraulic fluid may considerably reduce the life cycle of the valve.
- ▶ Observe the installation position specified in the "*Data sheet 22049-XE-710*".

7.3.1 Requirements on the valve subplate

WARNING

Explosion hazard caused by overheating!

Non-compliance with the requirements for the valve subplate will void the explosion protection.

- ▶ Observe the prescribed minimum distance when assembling several valves to form a valve battery, see "*Data sheet 22049-XE-710*".
- ▶ Observe the prescribed minimum size and minimum thermal conductivity of the valve connection surface, see "*Data sheet 22049-XE-710*".

Selection of incorrect subplates!

If subplates are used which are not listed in chapter 7.6, explosion protection will become void.

- ▶ You may only mount the valve on the subplates listed in chapter 7.6.
- ▶ If several valve subplates are assembled in battery operation, it must be observed that the minimum distance between the valve axes must be at least 55 mm.

7.4 Prior to assembly

WARNING

Explosion hazard due to wrong area of application!

A valve which is not approved for the area of application may cause an explosion!

- ▶ Check whether all the explosion protection marks on the name plate of the valve comply with the information in these operating instructions.
 - ▶ Please check if you have the right valve type by means of the type designation on the name plate of the valve.
 - ▶ Make sure that the zone and the temperature class correspond to the area of application of the valve.
- ▶ Check the scope of delivery for completeness and possible transport damage.
 - ▶ Also observe the safety instructions in chapter 2.6 "Product-specific safety instructions".
 - ▶ Transport protection elements (e.g. cover plates, protective plugs) must be removed prior to use in an explosive atmosphere.

7.5 Required tools

In order to assemble the valve, you need standard tools only.

7.6 Required accessories

The following accessories are recommended for the connection of the valve. These accessories are not included in the scope of delivery and can be ordered separately from Bosch Rexroth:

Subplates **Table 7: Subplates**

Type designation	Subplate type designation	Material number
M-3SED6 CK ...XE...SO710	HSA 06 R071-3X/P18 MT 00 SO710	R901231724
	HSA 06 R071-3X/P08 MT 00 SO710	R901333462
	HSA 06 R071-3X/MT 00 SO710	R901517496
M-3SED6 UK ...XE...SO710	HSA 06 R075-3X/P08 MT 00 SO710	R901338319

Valve mounting screws



The valve mounting screws are included in the scope of delivery of the subplates. They can also be ordered separately, see the following information.

Table 8: Valve mounting screws

Type	Quantity	Friction coefficient according to VDA 235-101	Material number
Hexagon socket head cap screw ISO 4762-M5x50-10.9 (corrosion-protected)	4	0.09...0.14	R913043758

Special tool



The special tool is used to operate the manual override.

Table 9: Special tool

	Material number
Special tool	R900024943

Address for ordering accessories and valves

The address of our responsible sales organizations can be found on the Intranet at www.boschrexroth.com and in the appendix 16.1 "List of addresses".

7.7 Assembling the valve

7.7.1 Installing the valve in the system

WARNING

Faulty installation of plug screws and lines!

Improperly fastened plug screws and lines may become loose during subsequent operation and may be ejected due to the pressure. This may cause severe injuries!

- ▶ Only pressurize your system after all plug screws and lines have been completely and properly mounted according to the specification.

Faulty mounting!

Mounting of the valve with valve mounting screws of reduced stability, insufficient mounting or fastening at blocks and plates with insufficient stability may lead to the valve becoming loose and falling down. Consequently, hydraulic fluid may leak and lead to personal injuries and/or damage to property. Particular caution applies to valves with suspended installation.

- ▶ Completely assemble the valve according to the assembly specifications by means of suitable assembly aids.
- ▶ Only assemble the valve at blocks or plates suitable for the weight of the valve.
- ▶ Observe the tightening torques, screw stability and the minimum length of the valve mounting screws.

CAUTION

Insufficient installation space!

Insufficient installation space may lead to jamming or abrasions in case of actuation and adjustment work at the valve.

- ▶ Provide for sufficient installation space.
- ▶ Ensure that actuation, adjustment elements and plug-in connectors are easily accessible.

Leaking hydraulic fluid!

Hydraulic fluid may leak during assembly and disassembly of the valve. This might cause persons to slip or fall.

- ▶ Do not remove the protective caps of the valve until assembly.
- ▶ After disassembly, seal the hydraulic fluid bores with suitable cap elements.
- ▶ Immediately remove hydraulic fluid that has leaked out.

NOTICE

Wear, tear and malfunctions!

The cleanliness of the hydraulic fluid has a considerable impact on the cleanliness and life cycle of the valve. Any contamination of the hydraulic fluid will result in wear and malfunctions. Particularly foreign particles may damage the valve.

- ▶ Always ensure absolute cleanliness.
- ▶ Install the valve in clean condition.
- ▶ Make sure that all connections, hydraulic lines and attachment parts are clean.
- ▶ Ensure that no cleaning agents are able to penetrate the hydraulic system.
- ▶ Only use seal kits as listed in chapter 10.6 "Spare parts".

1. Before any assembly and disassembly work starts, the environment must be cleaned so that no dirt can get into the oil circuit. Only fiber-free cloth or special paper may be used for cleaning.
2. Remove existing preservative agent.
3. Check the valve contact surface for the required surface quality (see "*Data sheet 22049-XE-710*"). Remove the protective plate from the valve and keep it safe for returns in case any repairs become necessary later.
4. Dry the valve connection surface using suitable cleaning materials.
5. Check the seal rings at the valve connection surface for completeness. Other sealants are not admissible.
6. Check whether at the subplate, the pressure connecting line is connected to P and the return line to T.



Exchanging P and T may cause damage at the valve in case of pressurization.

7. Place the valve on the contact surface.



Only use valve mounting screws with the thread diameters, screw lengths and strength properties listed in chapter 10.6 "Spare parts".

Always fasten the valve with all 4 valve mounting screws, otherwise leak-tightness is not guaranteed.

8. When using the subplates mentioned under 7.6 "Required accessories", tighten all four valve mounting screws with a tightening torque of $7 \text{ Nm} \pm 0.7 \text{ Nm}$ (with a friction coefficient of $\mu_{\text{total}} = 0.09 \dots 0.14$). This tightening torque refers to the maximum admissible operating pressure.

7.7.2 Hydraulic connection of the valve

CAUTION

Damage to the valve!

During operation, hydraulic lines and hoses installed under mechanical stress create additional mechanical forces, which reduces the life cycle of the valve and the complete machine or system.

- ▶ Assemble lines and hoses without stress.

1. Depressurize the relevant system part.
2. Establish all connections observing the operating instructions of the system.
3. Make sure that pipes and/or hoses are connected to all ports and/or that the ports are closed with plug screws.
4. Carry out a special check to make sure that the cap nuts and flanges are correctly tightened at the pipe fittings and flanges.



Mark all checked fittings, e.g. using a permanent marker.

5. Make sure that all pipes and hose lines and every combination of connection pieces, couplings or connection points with hoses or pipes are checked for their operational safety by a person with appropriate knowledge and experience.

7.7.3 Establishing the electrical connection

WARNING

High electrical voltage!

Danger to life, risk of injury caused by electric shock due to incorrect connection and faulty pin assignment.

- ▶ The valve may only be connected by or under the supervision of a specialized electrician.
- ▶ De-energize the system before the assembly, pulling and connecting plug-in connectors and all other installation works. Secure the electrical equipment against restarting.
- ▶ Provide for proper, safe PE connection.
- ▶ Check before switch-on whether the protective grounding conductors at all electric devices are firmly connected according to the connection diagram.
- ▶ Close the terminal box according to the guidelines in these operating instructions.

Explosion hazard due to missing equipotential bonding!

Electrostatic processes, an incorrect grounding concept or a lack of equipotential bonding may lead to an explosion. Apart from this, malfunctions or uncontrolled movements at the machine may be caused!

- ▶ Provide for correct grounding and provide for proper equipotential bonding.
- ▶ The base plate or subplate on which the valve is attached must be electrically conductive and included in the equipotential bonding according to IEC 60079-14 and IEC 60364-4-41.

Explosion hazard caused by overheating!

An incorrectly dimensioned fuse protection may lead to overheating and thus cause an explosion!

- ▶ Corresponding to the rated current, a fuse according to IEC 60127-2 has to be connected upstream of every valve solenoid (max. $3 \times I_{rated}$). The shut-off threshold of the fuse has to match the prospective short-circuit current of the supply source.
- ▶ The prospective short-circuit current of the supply source may amount to a maximum of 1500 A.
- ▶ This fuse may only be installed outside the potentially explosive atmospheres or must be of an explosion-proof design.

Explosion hazard caused by improper assembly!

No precautions are taken for safe connection of the shielding or sheathing in the terminal box of the valve solenoid and on the cable and line entry. The use of connection lines with shielding or sheathing can lead to potential backfeeding and is thus an explosion hazard!

- ▶ Only use connection lines without shielding or armoring.



For information on the prescribed pre-fuse, see "*Data sheet 22049-XE-710*".

CAUTION
Danger of damage to property and personal injuries!

Faulty energy supply may lead to uncontrolled valve movements. These could result in possible malfunctions or failure of the valve and cause injuries.

- ▶ Only use a power supply unit with safe separation.
- ▶ Always observe country-specific regulations.

Danger of short circuit caused by missing seals and caps!

Fluids may enter the valve and cause a short-circuit.

- ▶ Before commissioning, ensure that all seals and caps of the plug-in connections are leak-proof.

- ▶ When selecting the connection line, please observe the requirements regarding the temperature rating and/or avoid contact of the connection line with the surface of the valve solenoid. For selection and installation, observe the provisions of IEC 60079-14.
- ▶ Ensure that there are no bends in the connection line and braided wires to avoid short-circuits and interruptions.
- ▶ Only assemble the cable and line entries according to the assembly instructions. Before assembly, check whether the individual components of the cable and line entry are complete and that the sealing elements are undamaged.
- ▶ The sealing elements of the cable and line entry are only intended for single use.
- ▶ Only use finely stranded conductors if they have pressed-on wire end ferrules.
- ▶ Only use lines which satisfy the requirements for the terminal areas of the connection terminals and the cable and line entries, see "*Data sheet 22049-XE-710*".
- ▶ During the assembly, ensure leak-tightness between cable and line entry and terminal box. Route the connection line in a strain-relieved form. The first mounting point must be within 15 cm of the cable and line entry.



Connection of the valve solenoid is polarity-independent. Valve solenoids for connection to alternating voltage have a bridge rectifier which is integrated in the valve solenoid.

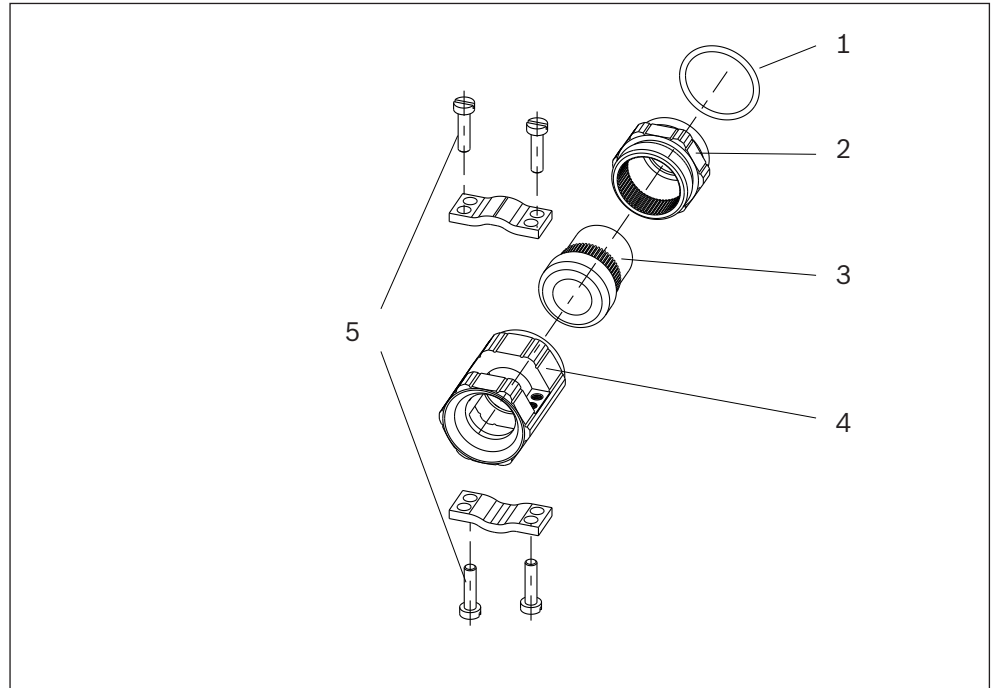

Fig. 3: Cable and line entry

- 1 O-ring
- 2 Double nipple
- 3 Seal insert
- 4 Screw-in bushing
- 5 Clamping screws of the strain relief



In the state as delivered, the cable and line entry is already screwed in the terminal box of the valve.

1. De-energize and depressurize the relevant system part.
2. Open the terminal box (internal hexagon, wrench size 3)
3. Remove the outer sheath of the connection line and the insulation of the individual conductors. Press the wire end ferrules to the individual conductors.



For the stripping lengths, refer to Fig. 4 and Table 10.

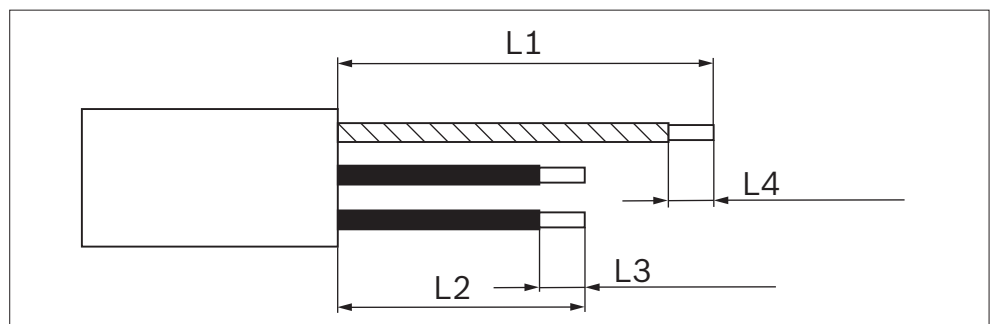

Fig. 4: Stripping lengths

- L1** Stripping length of the cable sheath and simultaneously resulting length of the individual conductor for the connection of the protective grounding conductor
- L2** Length of the individual conductors of the voltage supply
- L3** Stripping length of the insulation of the individual conductor for the attachment of the wire end ferrules
- L4** Stripping length of the individual conductor for protective equipotential bonding (PE) (internal)

Table 10: Stripping lengths

Cable and line entry position	Length L1 [mm]	Length L2 [mm]	Length L3 [mm]	Length L4 [mm]
Page manual override	≥ 44	24	5 +1	5 +1
Page valve housing	≥ 84	64	5 +1	5 +1

4. Disassemble the screw-in bushing and the clamping screws of the strain relief.
5. Ensure the correct seat of the seal insert in the double nipple.
6. Assemble the screw-in bushing **(4)** to the connection line and insert it through the seal insert **(3)** and the double nipple **(2)** in the terminal box.



The outer sheath of the connection line must lie in the sealing insert **(3)**. Otherwise, explosion protection and the IP protection are no longer ensured.

7. Screw the screw-in bushing **(4)** to the double nipple **(2)** and tighten it securely (hexagon nut, wrench size 22). When tightening the screw-in bushing **(4)**, the solenoid coil must be supported in an appropriate manner or held up at the double nipple **(2)** using an open-end wrench (wrench size 46).
8. Securely tighten the clamping screws of the strain relief **(5)**. The required tightening torque depends on the line diameter.
9. Guide the individual conductor into the connection terminal and screw this into place with the clamping screws.
Tightening torques for the clamping screws:

Table 11: Tightening torques

Operating voltage connection	0.4...0.5 Nm
Connection for protective grounding conductor	1.0...1.2 Nm
Connection for potential equalization conductor	2.0...2.4 Nm

10. Assemble the cover with the sealing device underneath.
Tighten the mounting screws with their spring washers diagonally, one after the other. Tightening torque of the cover screws: 1...1.1 Nm.

Assembling the cable and line entry on the opposite side of the terminal box

1. Dismount the solenoid coil (see chapter 7.7.4 "Rotating the solenoid coil by ± 90°").
2. Remove the plug screw (hexagon, wrench size 22).
3. Remove the cable and line entry. To do this, unscrew the cable and line entry from the double nipple **(2)**. Make sure not to lose the O-ring **(1)** between the housing and double nipple.

4. Assemble the cable and line entry at the opposite side of the terminal box.
Tightening torque of the double nipple **(2)**: 10..12 Nm
5. Assemble the plug screw. Tightening torque of the plug screw 7...9 Nm
6. Assemble the solenoid coil (see chapter 7.7.4 "Rotating the solenoid coil by $\pm 90^\circ$ ").

7.7.4 Rotating the solenoid coil by $\pm 90^\circ$

WARNING

Explosion hazard caused by improper assembly!

Improper assembly will result in the loss of the explosion protection!

- ▶ Strictly observe the following modification instructions for turning the valve solenoid.
- ▶ When turning the valve solenoid, make sure that it does not project over the valve connection surface.
- ▶ Make sure that the valve solenoid moves freely and does under no circumstance rest on the base plate.
- ▶ A gap between the valve housing and the valve solenoid is not admissible.
- ▶ Ensure that every solenoid coil is re-assigned to the original valve.
- ▶ After the rotation of the solenoid coil, the coil pin must engage in the bore of the valve housing.

Solenoid coils can be assembled in staggered assembly around the pole tube, i.e. the longitudinal axis of the valve, displaced by $\pm 90^\circ$.



The pole tube of the valve solenoid is completely sealed towards the oil circuit. The solenoid coil can therefore still be twisted if the valve has already been installed.

1. Detach the mounting nut of the valve solenoid at the pole tube (hexagon nut, wrench size 32).
2. Remove the solenoid coil and the O-ring from the valve and rotate it by 90° in the desired direction.
3. Re-attach the solenoid coil in the desired position. After the rotation of the solenoid coil, the coil pin must engage in the bore of the valve housing.
4. Assemble the O-ring onto the pole tube and slide it forward up to the solenoid coil.
5. Re-tighten the mounting nut of the valve solenoid (hexagon nut, wrench size 32, tightening torque 4 + 1 Nm). Afterwards, there must be no visible gap between the solenoid coil and the valve housing.

8 Commissioning

WARNING

Faulty assembly!

If the valve is not correctly mounted, persons might be injured and the valve or system could be damaged when commissioning the valve.

- ▶ Only commission your system after all hydraulic connections and the valve have been completely and properly mounted according to the specifications.
- ▶ Look out for defective sealing points and exchange defective seal rings immediately.
- ▶ Wear personal protective equipment during the initial commissioning.
- ▶ The solenoid coil may only be commissioned if mounted to the valve including pole tube and mounting nut and if the protective grounding conductor and the connection for potential equalization conductor are connected.

Inadmissibly high operating pressure!

In hydraulic applications with different area ratios, the hydraulic pressure is fortified and may - in case of incorrect design - lead to exceedance of the maximum admissible operating pressure. Thus, the valve may burst or the closing elements may be ejected and cause personal injury.

- ▶ Before commissioning the hydraulic system, ensure that the maximum admissible pressure of the valve in the system is not exceeded by any means.
- ▶ Ensure that in your system, the maximum admissible operating pressure is secured by means of a pressure limitation element.

Damage to persons and property!

Commissioning the valve requires basic hydraulic and electrical knowledge.

- ▶ Only qualified personnel (see chapter 2.4 "Qualification of personnel") is authorized to commission the valve.

NOTE

Risk of short-circuit!

Condensed water may form inside the terminal box and cause a short-circuit!

- ▶ Allow the valve to acclimatize for a few hours prior to commissioning as the electronics might be damaged by the generation of condensed water.

In order to commission the valve, proceed as described in the sections below:

Checking the connection line

The following applies to all valves irrespective of the type of connection:

- ▶ The connection line must be checked for proper condition by or under the guidance and supervision of a specialized electrician before the initial commissioning or any re-commissioning.
- ▶ Replace damaged connection lines.

Checking electrical connections

- ▶ Check the inside of the terminal box for corrosion. In case of visible corrosion, do not install the valve.
- ▶ Electrical connections in the terminal box must be checked for proper condition by or under the guidance and supervision of a specialized electrician before the initial commissioning or any re-commissioning.
- ▶ Seals are subject to a natural process of aging and, for this reason, check seals for damages every time the terminal box is opened and replace them if required.

Bleeding the hydraulic system

Observe the operating instructions of the device and/or system into which the valve is installed.

- ▶ Before the actual operation, switch the valve several times with reduced pressure (50 % operating pressure). This will press out any remaining air from the valve. Thus, mechanical damage caused by inadmissibly high acceleration of the fluid and the valve control spool is avoided and the life cycle of the valve is extended.



Do not switch the valve under operating pressure as this may cause damage.

- ▶ You can also achieve the switching movement of the valve control spool necessary for the bleeding procedure by manually actuating the manual override. For further information, refer to chapter 9.2 "Operating the manual override".

Performing a leak test

- ▶ Ensure that no hydraulic fluid leaks at the valve and the connections during operation.
- ▶ Check for internal leakage. The check must be carried out according to the possibilities present at the hydraulic system.



Internal leakage can be valve-specific but does not necessarily affect the functionality of the valve.

9 Operation

9.1 General information

WARNING

Explosion hazard caused by overheating!

Loss of explosion protection due to overheating!

- ▶ Simultaneously energizing both valves mounted on a subplate is not permitted, see "Data sheet 22049-XE-710".
- ▶ In case of bank assembly, adjacent valves must not be energized, see "Data sheet 22049-XE-710".

CAUTION

Loud noise!

An unfavorable arrangement of valves results in resonance or fluid noises, such as whistling. In continuous operation, these noises may cause hearing damage in persons or damage at the valves.

- ▶ In this case, contact a service engineer.

Only use the valve within the performance range provided in "Data sheet 22049-XE-710". The machine and/or system manufacturer is responsible for the correct project planning of the hydraulic system and its control. Changing the settings at the valve is not admissible.



For information on the operation, please refer to the operating instructions for the hydraulic system into which the valve is installed.

If errors occur, refer to chapter 14 "Troubleshooting".

9.2 Operating the manual override

NOTICE

Danger of damage to property!

An uncontrolled operation of the manual override bears the danger of damaging the system!

- ▶ Only operate the manual override if it is ensured that this will not trigger any dangerous working movement of the connected actuator.
- ▶ Do not use sharp-edged tools to operate the manual override.

The valves are equipped with a manual override. Using this manual override, the switching function of the valve can also be triggered if the solenoid is not energized. The manual override is only intended for manual operation. It is not suitable for frequently recurring manual operation.

The manual override is located on the side of the valve solenoid facing away from the valve.

- ▶ For operation, push the manual override in the direction of the valve housing using a rounded tool with a maximum diameter of 5 mm or using a dedicated special tool (see chapter 7.6 "Required accessories").

10 Maintenance and repair

10.1 Cleaning and care

NOTICE

Penetrating dirt and fluids will cause faults!

When dirt and fluids penetrate, safe function is no longer ensured.

- ▶ Always ensure absolute cleanliness when working at the valve.

Solvents and aggressive, highly inflammable cleaning agents!

Aggressive cleaning agents may damage the seals and the surface of the valve and let them age faster.

- ▶ Never use solvents or aggressive or highly inflammable cleaning agents.

Damage to the hydraulic system and seals!

A high-pressure washer's water pressure could damage the hydraulic system and the seals of the valve. The water displaces the hydraulic fluid from the hydraulic system and seals.

- ▶ Do not use a high-pressure washer for cleaning.

For cleaning and care of the valve, please observe the following:

- ▶ Close all openings with appropriate protective caps/devices.
- ▶ Check that all seals and caps of the plug-in connections are firmly fitted so that no humidity can penetrate the valve during cleaning.
- ▶ Remove external dirt and keep sensitive and important parts like valve solenoids clean.
- ▶ Remove dust and dirt accumulations from the valve at regular intervals.

10.2 Inspection and maintenance



WARNING

Uncontrolled machine movements!

Risk of injury due to maintenance work at an activated machine.

- ▶ Unless expressly prescribed otherwise, deactivate the machine via the main switch, lock it and remove the key before carrying out any work.

The following inspection, testing and maintenance work is to be carried out regularly. The intervals for the same have to be selected in a way that - also depending on the operating conditions - expected deficiencies are identified in good time. The check must, however, at least be carried out every **three years from the date of manufacture of the valve**. The date of manufacture of the valve can be seen on the name plate, see chapter 5.1.1 "Information on the name plate and the valve solenoid housing".



Before the initial commissioning or re-commissioning of the valve in a system, check whether the valve requires maintenance. If required, carry out maintenance.

For order details for seal kits, please refer to chapter 10.6 "Spare parts".

In order to ensure a long life cycle and functionality, include the following activities in your maintenance schedule for the overall system:

1. De-energize and de-pressurize the relevant system part.
2. Remove coarse dirt from the exterior.

CAUTION! Damage to persons and property caused by electrostatic charging!

- ▶ In order to avoid electrostatic charging, clean the valve using a damp cloth only.

3. Check all external fittings for completeness and tight seat.
4. Check the cable and line entry, plug screw, external grounding connection and connection line for tight seat.
5. Check the valve for external leakage and replace the sealing devices, if required, see chapter 10.5 "Rectifying external leakages".
6. Open the terminal box and replace any damaged seals. Observe the information on opening the terminal box from chapter 2.6.
7. Check the inside of the terminal box for corrosion. Corrosion is an indication of leakage. In case of visible corrosion, remove the valve and have it repaired.
8. Check the potting compound and internal lines and braided wires of the valve solenoid for visible damage. In case of visible damage, remove the valve and have it repaired.
9. Check all screws and connections for tight seat.
10. Check all connection lines for damage. Replace the connection line if there is any visible damage.

11. Replace all associated sealing elements with new ones each time the cable or line entry is released. The sealing elements are only intended for single use.
12. Re-assemble the cover of the terminal box with the seal beneath it. Tighten the mounting screws with the spring washers diagonally, one after the other. Tightening torque of the cover screws: 1...1.1 Nm.

10.3 Maintenance schedule

Valves require low maintenance if used as intended.

For a long and reliable operation of the valve, Bosch Rexroth recommends regularly checking the hydraulic system and the valve.

10.3.1 Checking for leakage

Check the valve for leakage. An early detection of hydraulic fluid loss may help you to identify and remedy errors. Bosch Rexroth therefore recommends that you keep the valve and/or the system permanently clean.

10.3.2 Checking for noise development

Check the valve for noise development. Based on noise development or the increase of noise development, a possible failure of one or several components can be recognized in time and consequential damage can be avoided.

10.3.3 Checking the mounting elements

Check that the mounting elements are attached firmly. All mounting elements are to be checked when the system is switched off, depressurized and has cooled down.

10.4 Repair

WARNING

Explosion hazard caused by improper repair!

Improper repair will void the explosion protection!

- ▶ For repair works, the valve may only be disassembled to the extent described in these operating instructions.
- ▶ Defective parts may only be replaced by new, interchangeable components in original equipment quality.

10.5 Rectifying external leakages

External leakage at the valve connection surface can be rectified on site. Other leakages have to be rectified by specialists of the manufacturer.

10.5.1 Rectifying leakage at the valve connection surface

1. Remove the valve, see chapter 11 "Disassembly and removal".
2. Inspect the contact surfaces for seal rings at the valve for cleanliness and damage.
3. Inspect the seal rings and recesses on the connection flanges for cleanliness and damage.
4. Dry the mounting surface and the contact surface using suitable cleaning materials.
5. Assemble the new sealing devices.
6. Re-assemble the valve at the contact surface, see chapter 7 "Assembly".

10.6 Spare parts

Seal kit for the valve connection surface

Table 12: Seal kit for the valve connection surface

Spare part	Material number
Seal kit for the valve connection surface	R961005258



Ensure the suitability of the sealing materials for the hydraulic fluid used! See "Data sheet 22049-XE-710".

Seal kit for the terminal box

Table 13: Seal kit for the terminal box

Spare part	Material number
Seal kit for the terminal box	R961009879

Valve mounting screws

Table 14: Valve mounting screws

Type	Quantity	Friction coefficient according to VDA 235-101	Material number
Hexagon socket head cap screw ISO 4762-M5x50-10.9 (corrosion-protected)	4	0.09...0.14	R913043758

In case of questions about spare parts, please contact your responsible Bosch Rexroth Service:
 Bosch Rexroth AG
 Service Hydraulics
 Bürgermeister-Dr.-Nebel-Str. 8
 97816 Lohr am Main
 Tel: +49 (0) 9352/40 50 60
 service@boschrexroth.de

For the addresses of our sales and service network please refer to:
www.boschrexroth.com/adressen

11 Disassembly and removal

WARNING

Danger of damage to property and personal injuries at pressurized or energized system parts!

For works at pressurized or energized system parts, there is a danger of injury by escaping hydraulic fluid or electric energy.

- ▶ Before disassembly, ensure that the hydraulic system is depressurized, and the electrical control is de-energized.

CAUTION

Falling of an incompletely disassembled valve!

An incompletely disassembled valve may fall down and cause injuries.

- ▶ During disassembly, secure the valve against falling.

Have sufficiently dimensioned collecting containers, sufficient cleaning cloths and medium-binding materials ready in order to collect or bind leaking hydraulic fluid.

1. De-energize and de-pressurize the relevant system part.
2. Disconnect the electrical connections professionally.
3. Prepare a container for collecting leaking hydraulic fluid.
4. Use suitable tools to loosen the valve mounting screws of the valve.
5. Remove the valve mounting screws and remove the valve from the mounting surface.
6. Collect escaping hydraulic fluid in the provided container and dispose of it properly.
7. If the valve is to be returned to the manufacturer for repair, please close the valve connection surface using the supplied protective plate or protect it using equivalent packaging in order to avoid contamination and damage.
8. Close the hydraulic channels of the subplate (on the customer side) to avoid contamination.

If the valve is exchanged, all further steps are analogous to mounting, see chapter 7 "Assembly".

12 Disposal

12.1 Environmental protection

Careless disposal of the valve and the hydraulic fluid may lead to environmental pollution.

- ▶ Thus, dispose of the product and the hydraulic fluid in accordance with the currently applicable national regulations in your country.
- ▶ Dispose of hydraulic fluid residues according to the applicable safety data sheets for these hydraulic fluids.
- ▶ Please observe the following information for the environmentally-friendly disposal of the valve.

12.2 Return to Bosch Rexroth AG

The hydraulic products manufactured by us can be returned to us for disposal purposes at no costs. There must be no inappropriate foreign substances or third-party components when products are returned. Valves must be drained before being returned. The components have to be delivered free to the following address:

Bosch Rexroth AG
Service Industriehydraulik [Industrial Hydraulics Service]
Bürgermeister-Dr.-Nebel-Straße 8
97816 Lohr am Main
Germany

12.3 Packaging

Upon request, reusable systems can be used for regular deliveries.

The materials for disposable packaging are mostly cardboard, wood, and expanded polystyrene. They can be recycled without any problems. For ecological reasons, disposable packaging should not be used for returning products to Bosch Rexroth.

12.4 Materials used

Hydraulic components from Bosch Rexroth do not contain any hazardous materials that could be released during intended use. Normally, no unfavorable effects on human beings and on the environment have to be expected.

The valves basically comprise of:

- Cast iron
- Steel
- Aluminum
- Copper
- Plastics
- Electronics components and assemblies
- Elastomers

12.5 Recycling

Due to the high metal content, hydraulic products can mostly be recycled. In order to achieve an ideal metal recovery, disassembly into individual assemblies is required. The metals contained in electric and electronic assemblies can be recovered by means of special separation procedures as well.

13 Extension and modification

WARNING

Explosion hazard caused by unauthorized modification!

Every non-permitted modification will void the explosion protection.

- ▶ Modifications exceeding the extent described in these operating instructions are not permitted.

14 Troubleshooting

14.1 How to proceed for troubleshooting

- ▶ Always work systematically and purposefully, even when under time pressure. In the worst case, random, thoughtless disassembly and changing settings might result in the inability to identify the original cause of error.
- ▶ First, get an overview of the functions of the valve in conjunction with the overall system.
- ▶ Try to find out whether the valve has worked properly in conjunction with the overall system before the error occurred.
- ▶ Try to determine any changes to the overall system in which the valve is integrated:
 - Were there any changes to the application conditions or area of application of the valve?
 - Have changes (e.g. refitting) or repair work been carried out at the overall system (machine/system, electrical systems, control) or at the valve?
If so: What were they?
 - Was the valve and/or the machine used as intended?
 - How did the fault become apparent?
- ▶ Try to get a clear idea of the cause of error. Ask the direct (machine) operator if required.

Fault table The valve is not sensitive to faults as long as the specified application conditions are complied with, in particular the oil quality and the operating temperature.

Table 15: Fault table

Error	Possible cause(s)	Remedy
Valve does not switch	Electrical connection interrupted, no current continuity	
	• Cable break	Replace connection line, refer to chapter 7.7.3 "Establishing the electrical connection"
	• Electrical defect in valve solenoid	Remove valve and have it repaired
	• Contact problems at the connection terminal	Check the mounting screws of the connection terminal and tighten using a manual torque wrench. Observe the instructions in chapter 7 "Assembly".
No pressure at P		Check and/or reapply pressure at port P
Control spool is jammed due to contamination		If possible, try to release the control spool by manually actuating the manual override. Refer to chapter 9.2 "Operating the manual override". If this fails: Remove valve and replace it with a new one.
External leakage	Seal defective	
	• Seal at the connection surface is defective	Remove the valve and replace the seals, refer to chapter 10.5.1 "Rectifying leakage at the valve connection surface"
	• Other leakage	Remove valve and replace it with a new one

In case of faults caused by contamination, it is important to check the oil quality in addition to the repair and improve it, if necessary, by suitable measures such as flushing or additional installation of filters.

15 Technical data

For the technical data of your valve, please refer to "*Data sheet 22049-XE-710*".

16 Appendix

16.1 List of addresses

Contacts for service and spare parts

Bosch Rexroth AG
Bürgermeister-Dr.-Nebel-Straße 8
97816 Lohr am Main
Germany

Phone +49 (0) 9352/40 50 60
Email service@boschrexroth.de



Headquarters

Bosch Rexroth AG
Zum Eisengießer 1
97816 Lohr am Main
Germany

Phone +49 (0) 9352/40 30 20
Email my.support@boschrexroth.de

The addresses of our sales and service network and sales organizations can be found at www.boschrexroth.com/adressen

16.2 Certificate according to technical rules EAC TR CU 012/2011 (excerpt)

ЕВРАЗИЙСКИЙ ЭКОНОМИЧЕСКИЙ СОЮЗ	
СЕРТИФИКАТ СООТВЕТСТВИЯ	
EAC	№ ЕАЭС <u>RU C-DE.BH02.B.00381/20</u>
	Серия RU № 0233478
<p>ОРГАН ПО СЕРТИФИКАЦИИ взрывозащищенных средств измерений, контроля и элементов автоматики федерального государственного унитарного предприятия «Всероссийский научно-исследовательский институт физико-технических и радиотехнических измерений» (ОС ВСИ «ВНИИФТРИ»). Место нахождения: 141570, Россия, Московская область, Солнечногорский район, город Солнечногорск, рабочий поселок Менделеево, промзона ФГУП ВНИИФТРИ, корпус 11. Адрес места осуществления деятельности: Россия, 141570, Московская область, Солнечногорский район, рабочий поселок Менделеево, промзона ВНИИФТРИ, корпус климатической лаборатории и специализированный полигон для испытаний оборудования, входящего в состав системы ГЛОНАСС. Регистрационный номер № RA.RU.11BH02 от 08.07.2015; телефон: +7 (495) 526-63-03; адрес электронной почты: ilvsi@vniiftri.ru</p>	
<p>ЗАЯВИТЕЛЬ Общество с ограниченной ответственностью «Бош Рексрот» Место нахождения: Россия, 141400, Московская область, город Химки, Вашпутинское шоссе, Владение 24. ОГРН: 1027700531451; телефон: +7 (495) 560 95 95; адрес электронной почты: info@boschrexroth.ru</p>	
<p>ИЗГОТОВИТЕЛЬ Bosch Rexroth AG (Германия) Место нахождения: Maria-Theresien-Strasse 23, 97816, Lohr am Main, Germany. Адрес места осуществления деятельности по изготовлению продукции: Bosch Automotive S.R.L., Aurel Vlaicu - Str. 2, 515400 Blaj, Romania.</p>	
<p>ПРОДУКЦИЯ Распределители клапанного типа M-3SED 6 CK1X/350CG24N9XEZ2 SO710 арт. R901238436, M-3SED 6 UK1X/350CG24N9XEZ2 SO710 арт. R901330744 Техническая документация изготовителя Серийный выпуск</p>	
КОД ТН ВЭД ЕАЭС	8481 20 100 9
СООТВЕТСТВУЕТ ТРЕБОВАНИЯМ	
Технического регламента Таможенного союза ТР ТС 012/2011 «О безопасности оборудования для работы во взрывоопасных средах»	
СЕРТИФИКАТ СООТВЕТСТВИЯ ВЫДАН НА ОСНОВАНИИ	
<ol style="list-style-type: none"> 1. Протокол испытаний № 20.3131 от 10.03.2020 выдан испытательной лабораторией взрывозащищенных средств измерений, контроля и элементов автоматики федерального государственного унитарного предприятия «Всероссийский научно-исследовательский институт физико-технических и радиотехнических измерений» (ИЛ ВСИ «ВНИИФТРИ») № RA.RU.21ИП09. 2. Акт о результатах анализа состояния производства № 1179 от 12.12.2019. 3. Техническая документация изготовителя. Эксплуатационные документы: Инструкция по эксплуатации R-RS 22049-XE-710-B / 02.20, техническая спецификация R-RS 22049-XE-710 / 2020-03. 4. Схема сертификации 1с. 	
ДОПОЛНИТЕЛЬНАЯ ИНФОРМАЦИЯ	
Сведения о стандартах, в результате применения которых на добровольной основе обеспечивается соблюдение требований технического регламента ТР ТС 012/2011, приведены в Приложении на бланке № 0736804. Сертификат действителен с Приложением на бланках № 0736804, № 0736805. Условия, сроки хранения, срок службы - в соответствии с Инструкцией по эксплуатации R-RS 22049-XE-710-B / 02.20, технической спецификацией R-RS 22049-XE-710 / 2020-03.	
СРОК ДЕЙСТВИЯ С	13.03.2020 ПО 12.02.2025
ВКЛЮЧИТЕЛЬНО	
Руководитель (уполномоченное лицо) органа по сертификации	 Елшина Галина Евгеньевна (ф.и.о.)
Эксперт (эксперт-аудитор) (эксперты (эксперты-аудиторы))	 Ольхов Николай Станиславович (ф.и.о.)
	
АО «Орикс», Минск, 2019 г. «Бюджетный № 02-05-09-000-000 РБ, ТЭ № 101. Тел: (495) 720-47-42, www.ors.ru	

ЕВРАЗИЙСКИЙ ЭКОНОМИЧЕСКИЙ СОЮЗ

ПРИЛОЖЕНИЕ

К СЕРТИФИКАТУ СООТВЕТСТВИЯ № ЕАЭС RU C-DE.BH02.B.00381/20

Серия RU № 0736804

1. Описание элементов конструкции и средств обеспечения взрывозащиты

Распределители клапанного типа M-3SED 6 CK1X/350CG24N9XEZ2 SO710 арт. R901238436, M-3SED 6 UK1X/350CG24N9XEZ2 SO710 арт. R901330744 (далее – клапаны) представляют собой распределители клапанного типа прямого действия с электромагнитным управлением. Клапаны предназначены для управления запуском, остановкой и направлением потока рабочей жидкости.

Распределители клапанного типа M-3SED 6 CK1X/350CG24N9XEZ2 SO710 арт. R901238436, M-3SED 6 UK1X/350CG24N9XEZ2 SO710 арт. R901330744 в части взрывозащиты соответствует требованиям ТР ТС 012/2011 «О безопасности оборудования для работы во взрывоопасных средах», ГОСТ 31610.0-2014 (IEC 60079-0:2011) «Взрывоопасные среды. Часть 0. Оборудование. Общие требования», ГОСТ Р МЭК 60079-7-2012 «Взрывоопасные среды. Часть 7. Оборудование. Повышенная защита вида «е», ГОСТ Р МЭК 60079-18-2012 «Взрывоопасные среды. Часть 18. Оборудование с видом взрывозащиты «герметизация компаундом «m» и им установлена Ех-маркировка по ГОСТ 31610.0-2014 (IEC 60079-0:2011):

2Ex e mc IIC T4 Gc X

Маркировка взрывозащиты, наносимая на оборудование и указанная в технической документации изготовителя, должна содержать специальный знак взрывобезопасности в соответствии с Приложением 2 ТР ТС 012/2011 и Ех-маркировку.

Клапаны выполнены в металлическом корпусе, состоящем из двух частей. Одна часть имеет вводное отделение и залитую компаундом электромагнитную катушку. Вводное отделение закрывается крышкой, закрепленной четырьмя болтами. В вводном отделении расположены клеммы для подсоединения проводов питания клапанов. Ввод проводов в вводное отделение осуществляется через кабельный ввод, свободное отверстие вводного отделения закрыто заглушкой. Во второй части клапана отсутствуют электрические цепи, в ней расположены седла клапана и запорный элемент.

Взрывозащита клапанов обеспечивается следующими средствами.

Клапаны не содержат искрящих элементов. Пути утечки и электрические зазоры между неизолированными токоведущими частями, имеющими различный потенциал, превышают минимальные значения, установленные ГОСТ Р МЭК 60079-7-2012.

Внутренние соединения выполнены так, что исключают возможность воздействия на них механических нагрузок.

Выводы для подключения внешних цепей имеют достаточный размер для надежного подсоединения проводов с поперечным сечением, соответствующим номинальному току, прочно закреплены и имеют конструкцию, исключающую их самоотсоединение или самоослабление.

Электромагнитная катушка клапанов изолирована от окружающей газовой среды заливкой компаундом. Заливка компаундом выполнена в соответствии с требованиями ГОСТ Р МЭК 60079-18-2012. Компаунд сохраняет свои свойства во всем диапазоне рабочих температур.

Конструкция клапанов выполнена с учетом общих требований ГОСТ 31610.0-2014 (IEC 60079-0:2011) для электрооборудования, размещаемого во взрывоопасных зонах. Уплотнения и соединения элементов конструкции обеспечивают степень защиты не ниже IP65 по ГОСТ 14254-2015 (IEC 60529:2013) «Степени защиты, обеспечиваемые оболочками (Код IP)». Механическая прочность оболочки соответствует требованиям ГОСТ 31610.0-2014 (IEC 60079-0:2011) для электрооборудования группы II с высокой степенью опасности механических повреждений. Фрикционная и электростатическая искробезопасность обеспечиваются характеристиками конструкционных материалов.

Максимальная температура нагрева поверхности и элементов клапанов в установленных условиях эксплуатации не превышает значений, допустимых для температурного класса Т4 по ГОСТ 31610.0-2014 (IEC 60079-0:2011).

На корпусе клапанов имеется табличка с указанием Ех-маркировки и знака «Х».

2 Условия применения

Распределители клапанного типа M-3SED 6 CK1X/350CG24N9XEZ2 SO710 арт. R901238436, M-3SED 6 UK1X/350CG24N9XEZ2 SO710 арт. R901330744 относятся к взрывозащищенному электрооборудованию группы II по ГОСТ 31610.0-2014 (IEC 60079-0:2011) и предназначены для применения во взрывоопасных зонах в соответствии с установленной маркировкой взрывозащиты, требованиями ТР ТС 012/2011, ГОСТ IEC 60079-14-2013 «Взрывоопасные среды. Часть 14. Проектирование, выбор и монтаж электроустановок», другими нормативными документами, регламентирующими применение электрооборудования во взрывоопасных зонах, инструкцией по эксплуатации R-RS 22049-XE-710-B / 02.20 и технической спецификацией R-RS 22049-XE-710 / 2020-03.

Возможные взрывоопасные зоны применения клапанов, категории взрывоопасных смесей газов и паров с воздухом – в соответствии с требованиями ГОСТ IEC 60079-10-1-2011 «Взрывоопасные среды. Часть 10-1. Классификация зон.

Руководитель (уполномоченное
лицо) органа по сертификации

Эксперт (эксперт-аудитор)
(эксперты (эксперты-аудиторы))

(подпись)

(подпись)



Елихина Галина Евгеньевна

(Ф.И.О.)

Ольхов Николай Станиславович

(Ф.И.О.)

Лист 1

ЕВРАЗИЙСКИЙ ЭКОНОМИЧЕСКИЙ СОЮЗ

ПРИЛОЖЕНИЕ

К СЕРТИФИКАТУ СООТВЕТСТВИЯ № ЕАЭС RU C- DE.BH02.B.00381/20

Серия **RU** № **0736805**

«Взрывоопасные газовые среды», ГОСТ Р МЭК 60079-20-1-2011 «Взрывоопасные среды. Часть 20-1. Характеристики веществ для классификации газа и пара. Методы испытаний и данные».

Установка, эксплуатация и техническое обслуживание клапанов должны проводиться в строгом соответствии с указаниями в инструкции по эксплуатации R-RS 22049-XE-710-B / 02.20 и технической спецификации R-RS 22049-XE-710 / 2020-03.

Знак «X», следующий за Ex-маркировкой, означает, что в температурном диапазоне от -43 до -10 °C допускается только максимально 50 переключений в течение всего срока службы распределителя клапанного типа.

Электрические параметры:

- номинальное напряжение, В.....24
- номинальная мощность, Вт.....17

Условия эксплуатации:

- температура окружающей среды, °C.....от -10 до +60
- относительная влажность воздуха при плюс 25 °C, %.....до 90

Внесение в конструкцию распределителей клапанного типа M-3SED 6 CK1X/350CG24N9XEZ2 SO710 арт. R901238436, M-3SED 6 UK1X/350CG24N9XEZ2 SO710 арт. R901330744 изменений, касающихся средств взрывозащиты, должно быть согласовано с ОС ВСИ «ВНИИФТРИ».

Руководитель (уполномоченное
лицо) органа по сертификации

Сидорова
(подпись)

Эксперт (эксперт-аудитор)
(эксперты (эксперты-аудиторы))

Ольхов
(подпись)



Евяхина Галина Евгеньевна

(Ф.И.О.)

Ольхов Николай Станиславович

(Ф.И.О.)

Лист 2

17 Index

▶ A		
Abbreviations	6	
Accessories	21	
Appendix	41	
Assembly	19	
▶ C		
Commissioning	30	
▶ D		
Damage to product	14	
Disassembly and removal	37	
Disposal	38	
▶ E		
Extension and modification	39	
▶ F		
Fault table	40	
▶ I		
Information	5	
Inspection	34	
Installation conditions	20	
Intended use	7	
▶ L		
List of addresses	41, 42	
▶ M		
Maintenance	34	
Maintenance and repair	33	
Maintenance schedule	35	
Manual override	32	
Materials used	38	
▶ N		
Name plate	16	
▶ O		
Obligations of the machine end-user	13	
Operation	32	
▶ P		
Packaging	38	
Personal protective equipment	12	
Product identification	16	
▶ Q		
Qualification of personnel	8	
▶ R		
Recycling	39	
Repair	35	
Required and amending documentation	5	
Risk classes	6	
▶ S		
Safety instructions	7	
Scope of delivery	15	
Spare parts	36	
Surface protection	19	
Symbols	6	
▶ T		
Technical data	40	
Transport and storage	17	
Troubleshooting	39	
▶ V		
Valve insert	12	
Valve subplate	20	

Bosch Rexroth AG

Zum Eisengießer 1

97816 Lohr a. Main

Germany

Tel: +49 (0) 9352/40 30 20

my.support@boschrexroth.de

www.boschrexroth.com