



# Industrial Pumps Catalog

A GLOBAL LEADER IN PUMP SOLUTIONS

**xylem**  
Let's Solve Water

# Contents

INDUSTRIAL PUMPS CATALOG

## 01 An Introduction to Pumps 4

How to Specify a Pump	6
CE Marking	7
Iconography	8
How Our Pumps Work	10

## 02 Centrifugal Pumps 14

Stainless Steel	16
Circulation	18
Mag Drive	21
Submersible	45

## 03 Diaphragm Pumps 48

Introduction	50
Motor Driven	52
Air Driven	70
Accessories & Fittings	76

## 04 Flexible Impeller Pumps 80

Introduction	82
Epoxy / Phenolic Plastic	84
Bronze	92
Stainless Steel	111
Introduction to Sanitary Pumps	118
Stainless Steel Sanitary Pumps	120
Model Variants	128
Impeller Replacement Guide	130

## 05 Hand Pumps 138

Portable & Manual	140
-------------------	-----

## 06 Rotary Lobe Pumps 142

Hygienic Pumps	144
----------------	-----

## 07 Oscillating Pumps 148

Oscillating Pumps	150
-------------------	-----

## 08 Sliding Vane Pumps 152

Diesel Sliding Vane	154
---------------------	-----

## 09 Specialty Products 156

Blowers	158
Bottled Water Systems	161
Oil Changers	164

## 10 Chemical Resistance Guide 168

Introduction	170
Chemical Resistance Guide	172

## 11 Additional Information 180

Conversion Data	182
Warranty & Return Policy	184

# An Introduction to Pumps 01

How to Specify a Pump

CE Marking

Iconography

How Our Pumps Work



# 01 An Introduction to Pumps

## INTRODUCTION

### How to Specify a Pump

The first step toward selecting the right pump is to develop the specifications for the pump. This involves knowledge of the application and the chemical solution for pumping. The following tips will be helpful in determining the right pump for any specific application. Please refer to the engineering data and tables within this catalog to assist you in this process.

#### FLOW

"Flow" is defined as the rate at which you want the liquid pumped. Several factors dictate the flow requirements in an application. Some of these are the size of the nozzle for spraying, cycle time for transferring and volume of the liquid per cycle for dispensing applications. In case there is a choice, it is always advisable to choose a lower flow rate which will increase the life and reliability of the pump.

#### HEAD/PRESSURE

Head or pressure in combination with the flow rate determine the power of a pump needed for a given application. This is a simple calculation in cases where the discharge is at a higher level than suction, and is determined by the differential height between the liquid level on the suction and discharge side. The pressure needed may also be controlled by the flow required through a nozzle, or other restrictions in the delivery line such as a long or narrow tube. The frictional loss through the tube and the fitting dictates the pressure required at a certain flow. The required pressure also includes difference in the pressure of the suction and the discharge vessel when pumping into a higher-pressured vessel or from a vacuum. As always when pumping at pressure, make sure you choose a pump for the pressure needed in the system. It is also worth noting that high pressure requires pressure-rated tubing and fittings, adding to the cost of your overall system as well as the increased risk of leakage.

#### CONTROL

What turns the pump on and off is an important consideration since running the pump longer than required reduces pump life. For applications where there is a closed valve or a spray wand with a trigger, it is advisable to use a demand pump with a pressure switch to shut the pump off when the valve is closed. Running a positive displacement pump against a dead head could cause immediate failure. For other applications, it is useful to have a bypass system to prevent failure. More complicated pump controls may involve sensors and electronics.

#### PUMP DRIVER

The decision to choose the right driving source is generally dictated by availability. If the pump is to be motor or solenoid driven, you will need to know the voltage and the frequency of the power source. AC or DC governs the kind of motor needed. The oscillating pumps that run on the cycling of the AC supply cannot work with DC voltages. If you have air available and choose an air driven pump, you need to know the pressure and means of regulating the incoming air to the pumps. In flammable atmospheres, Xylem recommends using an air driven pump properly grounded to prevent the potential of explosion.

#### CHEMICAL COMPATIBILITY

It is essential to get all the details, including the exact composition, temperatures and the concentration of the chemicals to be pumped. This information helps you choose the material of construction for the pumps for chemical compatibility. Corrosion causes leakage and failure. Refer to the chemical compatibility sheet in the back of the catalog as a guide. However, an actual soak test of the materials is strongly recommended before applying the pump.

#### PRIMING

The pump needs to be primed when it is located above the level of the liquid or where a flooded suction cannot be provided. Most positive displacement pumps can self-prime as long as you stay within the limit of its priming capability. If that limit is exceeded, the pump will not prime and, hence, will not pump. This will lead to a condition where the pump runs without any liquid. This dry running will lead to early failure of the pump if it happens frequently and over extended periods of time.

#### VISCOSITY

Viscosity is the internal property of fluid that offers a resistance to flow as it is placed under sheer or extensional stress. In general, it is the measure of the thickness of the fluid or of the fluid friction when trying to flow. For example, water is considered thin; it has low viscosity and can be pumped at higher volumes and speeds in positive displacement pumps. Oils are higher in viscosity and, therefore, the pump used or the volumes or pressures possible are lower. Apart from the type of liquid, many other factors can either reduce or increase the effect of a viscous fluid. Pump orientation, pump speed, port size, system pipe work dimensions and length can all have an effect.

It is worth noting that viscosity in fluid is also highly temperature dependent. For better pumping, high viscosity fluids can be pumped with certain agitation of the material. Agitation could be as simple as a slight stirring or heating of the medium, but care should be exercised if attempting to alter the viscosity for pumping. Each product to be transferred needs to be considered on its own design characteristics to agitation.

*Other important considerations, such as the duty cycle, plumbing and ambient temperature all have a direct bearing on the performance of a pump and need to be clearly understood and defined.*

THE IDEAL PUMP FOR YOUR INDUSTRY	This table will help you to identify the products which are most commonly used in your sector. Don't forget to look at the other pages too, as you may find something which meets your specific requirements.							
	Industrial Flexible Impeller Pumps	Bronze Flexible Impeller Pumps	Hygienic Flexible Impeller Pumps	Rotary Lobe Pumps	Sliding Vane Pumps	Diaphragm Pumps	Centrifugal Pumps	
Page	80	92	118	142	152	48	14	
Chemical Suppliers & Users	•	•		•		•	•	
General Industry, Factory Plant	•	•		•	•	•	•	
Water Treatment & Utilities	•	•			•	•	•	
Food Processing			•	•				
Cosmetics & Pharmaceuticals			•	•				
Dairy, Beverage & Soft Drinks			•	•		•		
Construction Equipment		•			•	•	•	
Agricultural Equipment		•			•	•	•	

### CE Marking



The CE marking is a mandatory conformity mark on many products placed on the single market in the European Economic Area (EEA). The CE marking certifies that a product has met EU health, safety and environmental requirements, which ensure consumer safety.

By affixing the CE marking, Xylem, its authorized representative or person placing the product on the market or putting it into service asserts that the item meets all the essential requirements of the relevant European Directive(s).

Products identified in this book as "CE" meet all the relevant requirements and have gone through either internal or external testing to evaluate the product and its documentation.

# 01 An Introduction to Pumps

ICONOGRAPHY

## Iconography



The industry-specific icons shown here serve the same purpose as road signs: They are designed to help navigate through this catalog. The signs help to give direction and, hopefully, a better understanding of the products Xylem offers.

### PRIMARY MARKETS



#### AGRICULTURAL SPRAYING

Many applications around the farm that require spraying; from crop/tree spraying to teat spraying. Product groups with this icon are designed to have the pressure and flow required for such applications.



#### CAR WASH

Pumps designed for car washes are ideally suited for pumping both water and chemicals.



#### AUTOMOTIVE

Pumps used in this application are perfect for the garage and also for washing car brakes, transmission fluid transfer, brake fluid change out and windshield washing.



#### CHEMICAL TRANSFER

Products with this symbol are designed specifically for the harshness of a chemical transfer and to handle a full range of chemicals.



#### ASPHALT PAVING & SWEEPING

Product types with this icon generally have specific products that are designed for the harsh environment and long duty of these applications.



#### CONSTRUCTION

This icon represents products for the asphalt street sweepers, asphalt paving machines, chemical injection into concrete pouring systems and concrete cutting machines.



#### FLOOR CARE

Pumps shown with this icon are used in commercial and consumer rental carpet cleaning machines, self-propelled hard surface scrubbers, water dumping systems and carpet pre-treat sprayers.



#### PHARMACEUTICAL

Products with this symbol have options designed specifically for the high grade of cleanliness necessary in the pharmaceutical world.



#### ROAD COMPACTION

Products in this category are particularly suited to road compaction vehicles where liquid spraying is required.



#### WATER

This symbol represents certain products for use with water transfer, water spraying or water systems.



#### DIESEL REFUELING

Products with this logo have been specifically designed for diesel refueling where durability and speed are key.



#### FOOD & BEVERAGE

Specific products in this group are designed for food grade materials and range in applications from dispensing beer to pumping food over large distances.



#### FORESTRY

Refueling pumps are used on forestry machines (Harvesters and Forwarders) where environmental considerations are important. Pumps with this icon offer valves and auto shut-off devices.



#### GENERAL PURPOSE

These products have a large range of attributes from high volume water transfer to pumping chemicals.



#### PERSONAL CARE

Hygienic processing pumps are designed to comply with the stringent requirements of the personal care/cosmetic industry. These pumps are ideal for processing cosmetics, creams, lotions and certain dietary products.

### SECONDARY MARKETS



HVAC



HAZARDOUS AREA ENVIRONMENTS



ROBOTICS



STEAM



PROCESS APPLICATIONS



CRYOGENICS

# 01 An Introduction to Pumps

HOW OUR PUMPS WORK

## Centrifugal



Centrifugal pumps handle high volumes with a smooth and non-pulsating flow. The flow rate can be regulated from maximum output to no flow with no damage to the pump. An excellent pump for general transfer applications.

**Low Maintenance:** Few moving parts mean that wear due to operation is minimal.

**Easy Installation:** Compact size for flow rate. Option of port position simplifies pipe runs.

**Versatility:** Centrifugal pumps can be built in submersible form.

**Low Power Consumption:** Electric centrifugal pumps consume less power than most other pump types.

### HOW DO THEY WORK?

1. The rotating impeller gives velocity energy to the liquid, moving it to the periphery of the volute casing and toward the discharge port.
2. The volute casing discharge arrangement converts velocity energy into static pressure.
3. Centrifugal pumps must be either initially primed or mounted in such a way that liquid is permanently available at the inlet port (e.g., submersible pumps).



## Mag Drive Centrifugal



Magnetically driven pumps handle products where leak-free transfer is a must, where high reliability is paramount and purity of the pumped medium must be maintained. The operation is identical to any centrifugal pump except that the need for the shaft seal is eliminated. This is accomplished by driving the impeller with a magnetic coupling rather than directly with the motor shaft. An excellent pump for chemical transfer applications.

**Low Maintenance:** Few moving parts mean that wear due to operation is minimal.

**No Shaft Seal:** Removes the leak path to and leak path from the medium being pumped.

**Easy Installation:** Compact size for flow rate.

### HOW DO THEY WORK?

1. The rotating impeller gives velocity energy to the liquid, moving it to the periphery of the volute casing and toward the discharge port.
2. The volute casing discharge arrangement converts velocity energy into static pressure.
3. Centrifugal pumps must be either initially primed or mounted in such a way that liquid is permanently available at the inlet port (e.g., submersible pumps).



## Diaphragm



Xylem Flojet diaphragm pumps can be found in applications such as spraying, misting, carpet cleaning, water systems, chemical transfer, car wash and many other unique functions. Diaphragm pumps tend to be more robust as they can run dry for extended periods and also do not need a shaft seal, so there is less maintenance. Xylem Flojet diaphragm pumps come in two ranges – air/gas powered and electrically powered. Air/gas powered diaphragm pumps offer great life and superb flow with a small footprint. Electric diaphragm pumps are compact and have a huge range of options for wetted materials, voltage, pressure switch setting and flow. Diaphragm pumps must be used with a coarse strainer to avoid blocking the check valves.

### HOW DO THEY WORK?

1. The diaphragm, pulled by the movements of a piston or a handle, causes a partial vacuum, opening the inlet port and closing the outlet, drawing in liquid.
2. Downward movement of the diaphragm pressurizes the liquid, closing the inlet valve and opening the outlet valve through which liquid is expelled by pressure.

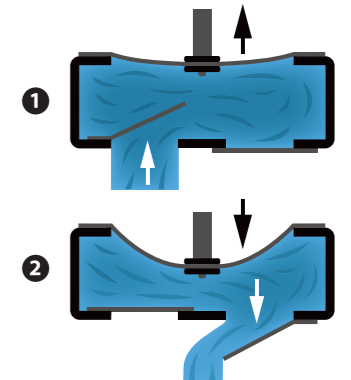

## Flexible Impeller



The flexible impeller pump combines the priming features of positive displacement type pumps with the general transfer ability of centrifugals. It will pump either thin or viscous liquids and can handle more solids in suspension than other types of rotary pumps. The pump can be mounted at any angle and will pump in either direction with equal efficiency.

**Self-Priming:** Pumps instantly with dry suction lifts up to 10' (3m) and up to 25' (8m) when wetted.

**Simplicity:** One moving part – a tough, long-life, wear-resistant flexible impeller.

**Flexibility:** The flexible impeller pump offers both high flow and high pressure according to motor and impeller design.

### HOW DO THEY WORK?

1. As the flexible impeller blades contact the offset cam, they bend with a squeezing action that provides a continuous and uniform flow.
2. As the impeller rotates, each successive blade draws in liquid and carries it from intake to outlet port.
3. Flexible impeller blades create a nearly perfect vacuum for instant self-priming.

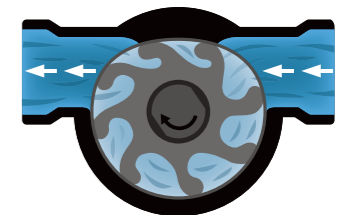

# 01 An Introduction to Pumps

HOW OUR PUMPS WORK

## Rotary Lobe



Xylem Jabsco lobe pumps use two counter-rotating rotors that create a steady, positive pumping action. As the rotors never touch each other or the pump case, Jabsco hygienic lobe pumps will not contaminate or degrade the fluid. What comes out is what goes in; no more, no less.

**Hygiene Standards:** Crevice-free designs, external gears and bearings, together with all-stainless-steel contact parts and high surface finishes, surpass users' hygiene and cleanability expectations.

**Reliability:** Lobe pumps offer long-term dependability with minimal cost of servicing and replacement parts.

**Application Capability:** Lobe pumps generate the highest pressures and flow rates delivered by any of the Xylem Jabsco product range. Highly viscous, shear-sensitive liquids and suspended soft solids will not be degraded.

### HOW DO THEY WORK?

1. Fluid is drawn into the pump and completely fills the space between the rotors.
2. Held between the rotor lobes and the pump case, closed cells of fluid are carried smoothly through the pump.
3. The intermeshing rotor lobes positively displace the fluid volume, generating flow and overcoming the discharge pressure.

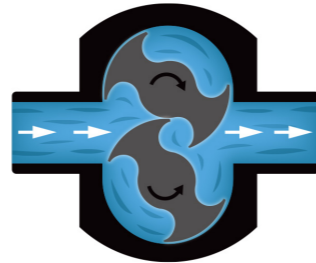

## Sliding Vane



Sliding vane pumps are designed for the transfer of diesel fuel and light oils. Many have excellent priming capabilities that enable them to be mounted high on construction machines and prime through strainers and check valves.

### HOW DO THEY WORK?

1. The rotor is eccentric to the rotor bore and the vanes slide outwards by the centrifugal force induced by the turning rotor.
2. As the rotor turns from the top to the bottom of the body bore, a partial vacuum is created by the increasing volume of the cell. This allows atmospheric pressure to push liquid into the pump.
3. The liquid is then transferred to the discharge side of the pump. As the rotor turns from the bottom to the top of the body bore, pressure is created by the reducing volume of the cell and forces the liquid out of the discharge port.

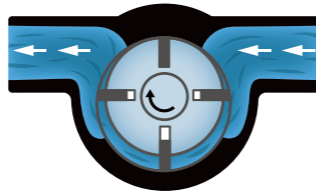

## Solenoid

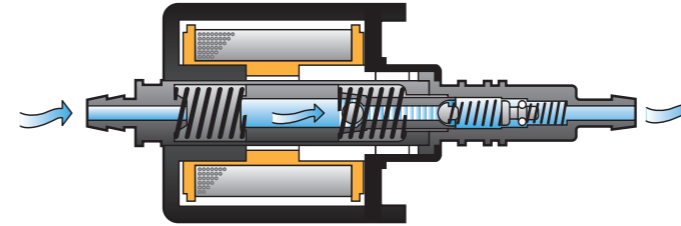

Building on our extensive experience in positive displacement pumps, Flojet's new PS Series Oscillating pumps provide a compact solution for low flow, high pressure applications

### HOW DO THEY WORK?

1. Solenoid pumps use an AC electrical coil rather than a motor to power the pumping action.
2. The AC voltage passes through a diode so that the voltage applied to the coil is positive polarity only and is effectively pulsed. This is known as a half wave rectifier
3. Inside the pump, there is a metal plunger fitted between two springs, as this plunger moves backwards and forwards it move the liquid through the pump. A check valve in the outlet of the pump prevents backward flow of the liquid.
4. The metal plunger in the pump is magnetized and is pulled towards the inlet of the pump when the coil energizes. When the coil de-energizes, the plunger moves forward due to the springs. The action of the plunger moving backwards and forwards due to the coil energizing and de-energizing is the fundamental principle behind the operation of the pump.

# Centrifugal Pumps 02

- Stainless Steel
- Circulation
- Mag Drive
- Submersible





# 02 Centrifugal Pumps

STAINLESS STEEL



## Cyclone™ Stainless Steel Centrifugal Pump



The combination of reliability, performance, and silent operation is what makes the Cyclone™ range the class leader and is why these robust pumps are supported by many major customers and OEMs worldwide. The Hybrid Cyclone™ model was developed in response to industry application requirements and our customers' needs to increase the pump's versatility and performance criteria.

### FEATURES

- Heavy duty robust design
- Stainless steel construction
- Long-life DC motor
- Silent running
- Anti-clog impeller design
- Long-life mechanical seal
- Single tool servicing
- 6.6' (2m) suction lift when wet

### PERFORMANCE

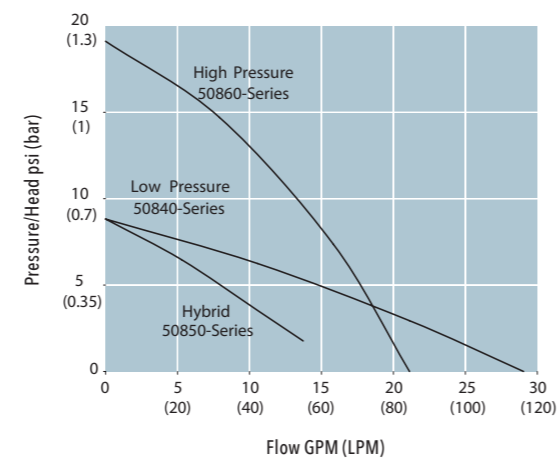

### GAS WARNING

No pump manufactured by Xylem should be used for gasoline or any fluid with a flash point below 100°F (38°C).



### SPECIFICATIONS

MODEL #	CERTIFICATION	DESCRIPTION	VOLTAGE	FUSE SIZE	PORT FITTING	OPEN FLOW	RECOMMENDED DUTY	MOTOR LIFE
50840-0012	CE	Cyclone low pressure	12V	10	3/4" (19mm) NPT	31 GPM (120 LPM)	Continuously rated	3500 hours
50840-0024	CE	Cyclone low pressure	24V	5	3/4" (19mm) NPT	31 GPM (120 LPM)	Continuously rated	3500 hours
50840-2012	CE	Cyclone low pressure	12V	10	3/4" (19mm) BSP	31 GPM (120 LPM)	Continuously rated	3500 hours
50840-2024	CE	Cyclone low pressure	24V	5	3/4" (19mm) BSP	31 GPM (120 LPM)	Continuously rated	3500 hours
50850-0012	CE	Cyclone hybrid	12V	7	3/4" (19mm) NPT	13 GPM (50 LPM)	Continuously rated	3500 hours
50850-2012	CE	Cyclone hybrid	12V	7	3/4" (19mm) BSP	13 GPM (50 LPM)	Continuously rated	3500 hours
50850-2124	CE	Cyclone hybrid	24V	5	3/4" (19mm) BSP	13 GPM (50 LPM)	Continuously rated	3500 hours
50860-0012	CE	Cyclone high pressure	12V	25	3/4" (19mm) NPT	21 GPM (80 LPM)	30 minutes on, 30 minutes off	2500 hours
50860-0024	CE	Cyclone high pressure	24V	15	3/4" (19mm) NPT	21 GPM (80 LPM)	30 minutes on, 30 minutes off	2500 hours
50860-2012	CE	Cyclone high pressure	12V	25	3/4" (19mm) BSP	21 GPM (80 LPM)	30 minutes on, 30 minutes off	2500 hours
50860-2024	CE	Cyclone high pressure	24V	15	3/4" (19mm) BSP	21 GPM (80 LPM)	30 minutes on, 30 minutes off	2500 hours

### 50840 SERIES DIMENSIONAL DRAWINGS

Unless otherwise stated, dimensions are in inches and (mm).

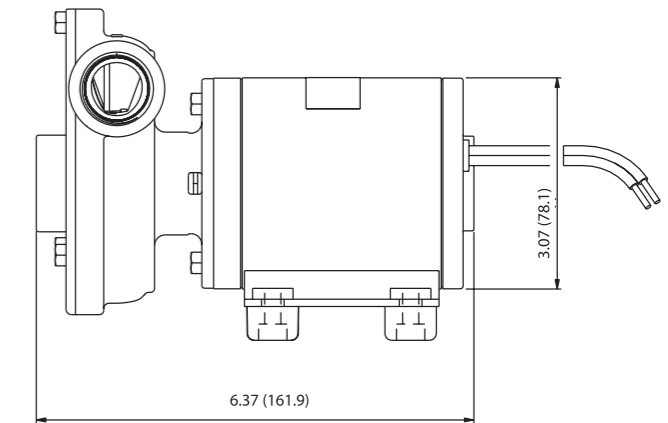
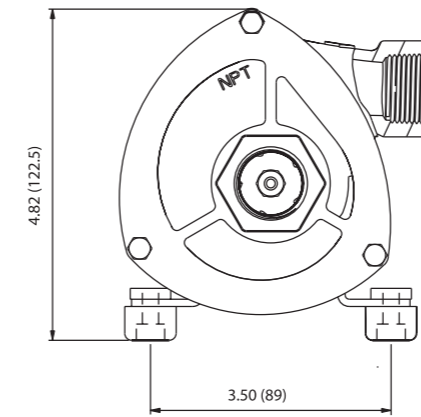

### 50850 SERIES DIMENSIONAL DRAWINGS

Unless otherwise stated, dimensions are in inches and (mm).

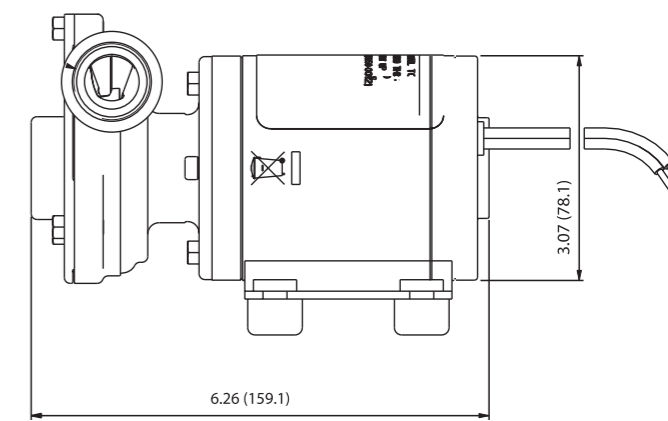
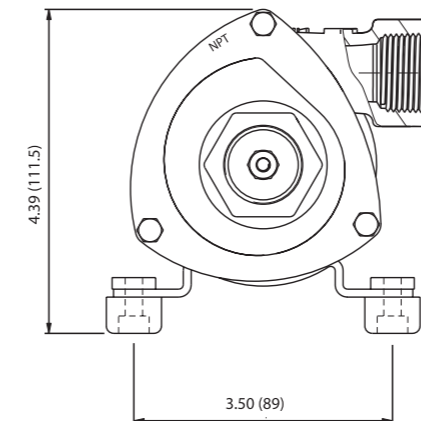

### 50860 SERIES DIMENSIONAL DRAWINGS

Unless otherwise stated, dimensions are in inches and (mm).

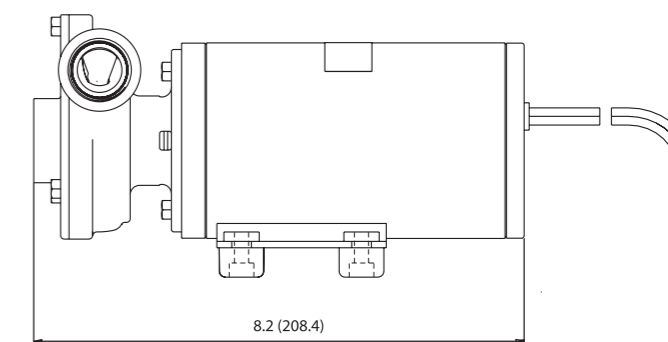
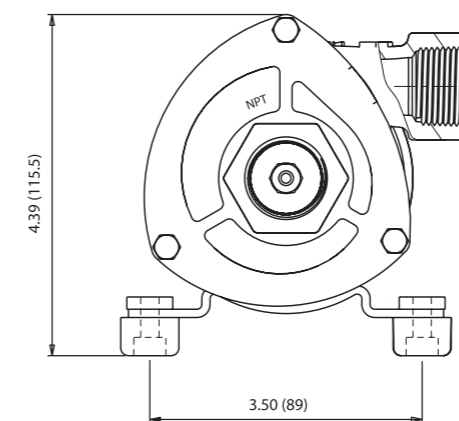

# 02 Centrifugal Pumps

CIRCULATION



## Commercial Circulation Pump 59510 Series

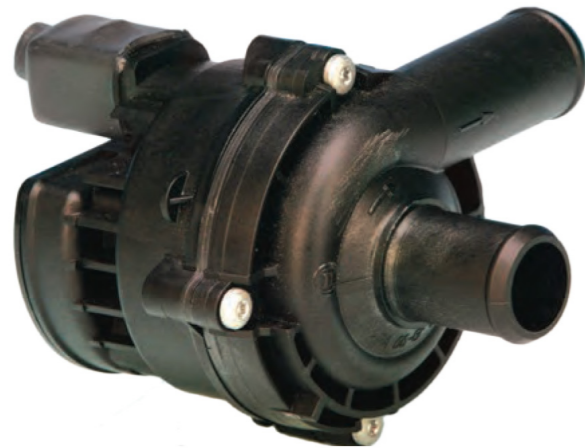

### FEATURES

- 3.3 GPM (12.5 LPM) @ 1.7 psi (0.12 bar)
- Magnetic drive – sealed pump chamber
- Ignition protected
- Meets EMC requirements
- Connections for 3/4" (19mm) ID hose
- Continuously rated
- Pumps water at 212°F (100°C)
- Long-life brushless DC motor

### PERFORMANCE

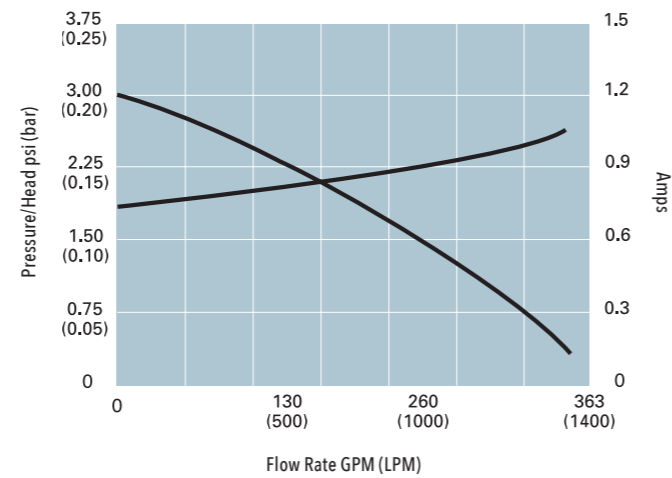

### MODELS

MODEL #	CERTIFICATION	VOLTAGE	FUSE SIZE	CURRENT DRAW	CABLE LENGTH	MINIMUM WIRE SIZE
59510-0012	CE	12V DC	2A	1.2A	0-27' (0-8m) 27-50' (8-15m)	0.1in <sup>2</sup> (2.5mm <sup>2</sup> ) AWG 12 0.16in <sup>2</sup> (4mm <sup>2</sup> ) AWG 10

### DIMENSIONAL DRAWINGS

Unless otherwise stated, dimensions are in inches and (mm).

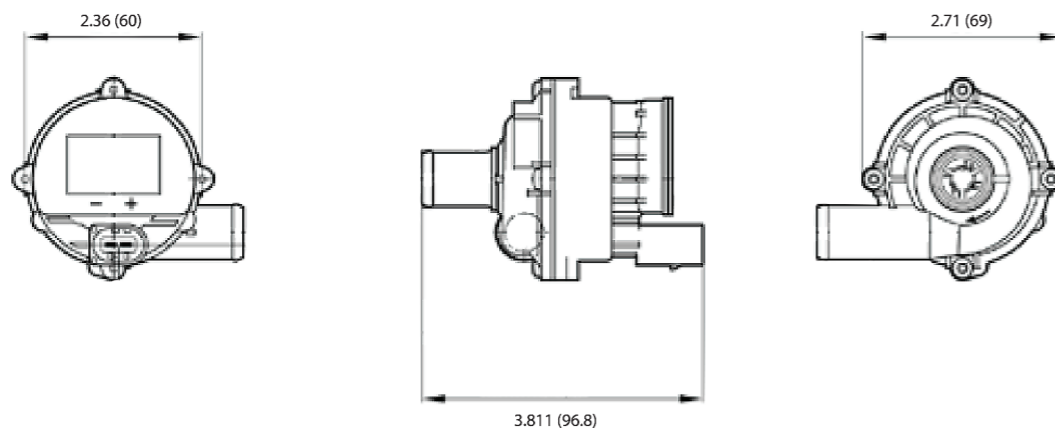

## Commercial Circulation Pump 59520 Series



### FEATURES

- Up to 5.5 GPM (21 LPM) @ 1.5 psi (0.1 bar)
- Variable flow – 5 speed control
- Ignition protected
- Meets EMC requirements
- Connections for 1/2" BSP (13mm)
- Continuously rated
- Pumps water at 176°F (80°C)
- Handles aggressive liquids
- Long-life brushless DC motor

### PERFORMANCE

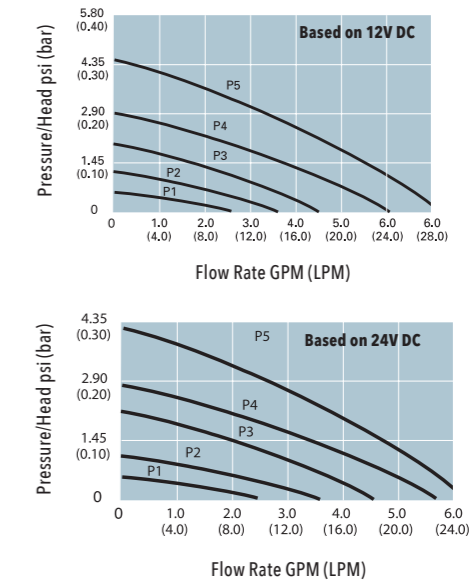

### MODELS

MODEL #	CERTIFICATION	VOLTAGE	FUSE SIZE	CURRENT DRAW	CABLE LENGTH	MINIMUM WIRE SIZE
59520-0000	CE	8-24V DC	2.5A	1.8A	0-27' (0-8m) 27-50' (8-15m)	0.1in <sup>2</sup> (2.5mm <sup>2</sup> ) AWG 12 0.16in <sup>2</sup> (4mm <sup>2</sup> ) AWG 10

### DIMENSIONAL DRAWINGS

Unless otherwise stated, dimensions are in inches and (mm).

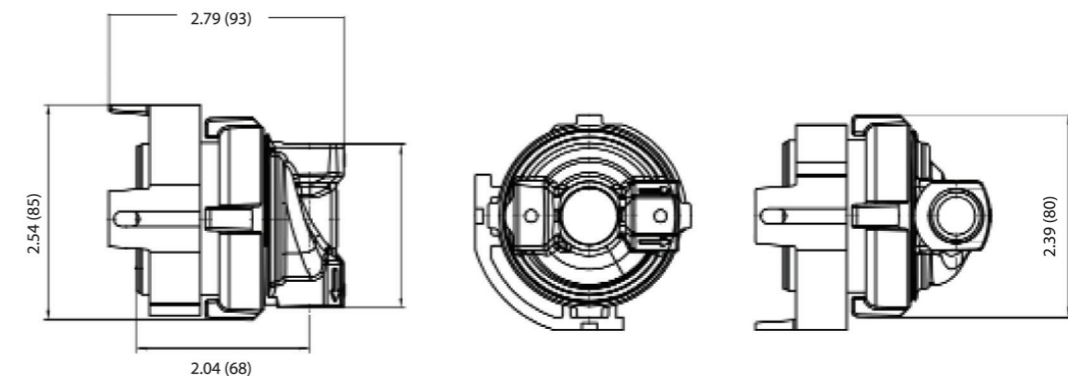

# 02 Centrifugal Pumps

CIRCULATION



## Commercial Circulation Pump 59530 Series



### FEATURES

- Up to 5.5 GPM (21 LPM) @ 1.5 psi (0.1 bar)
- Variable flow – 5 speed control
- Ignition protected
- Meets EMC requirements
- Connections for 3/4" (19mm) bore hose
- Continuously rated
- Pumps water at 176°F (80°C)
- Long-life brushless DC motor

### PERFORMANCE

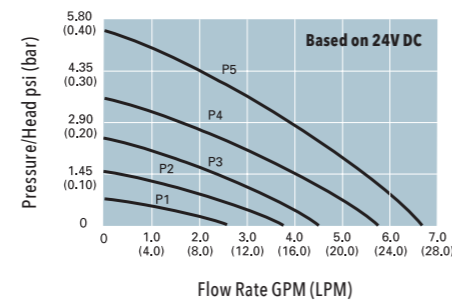
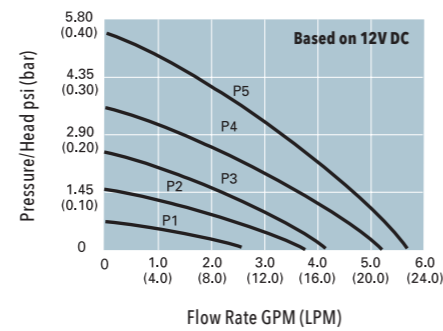

### MODELS

MODEL #	CERTIFICATION	VOLTAGE	FUSE SIZE	CURRENT DRAW	CABLE LENGTH	MINIMUM WIRE SIZE
59530-0000	CE	8-24V DC	2.5A	1.8A	0-27' (0-8m) 27-50' (8-15m)	0.1in <sup>2</sup> (2.5mm <sup>2</sup> ) AWG 12 0.16in <sup>2</sup> (4mm <sup>2</sup> ) AWG 10

### DIMENSIONAL DRAWINGS

Unless otherwise stated, dimensions are in inches and (mm).

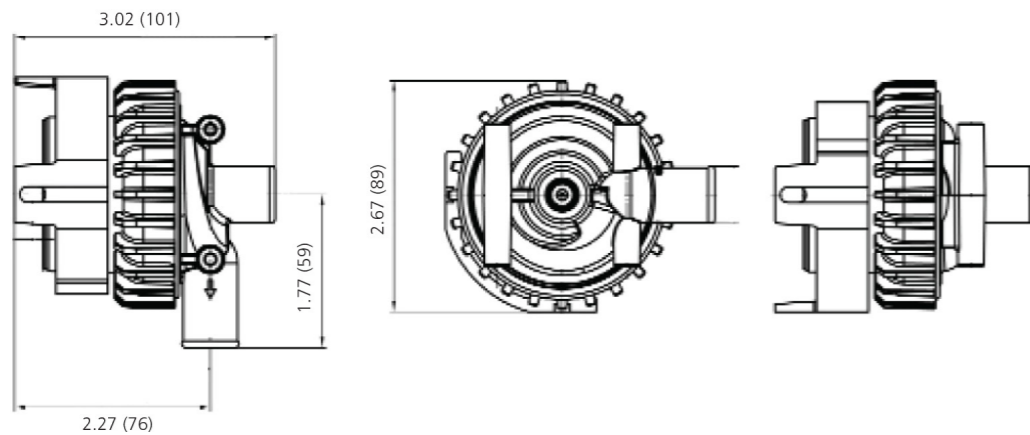

# Centrifugal Pumps 02

MAG DRIVE

## HPR10/15



Designed for continuous recirculation of carbonated water, aggressive chemicals, chilled water, pure or precious liquids in high pressure systems.

### FEATURES

- Manufactured in chemically resistant thermoplastics
- Operating at an optimum flow rate of 1.3 GPM (5 LPM)
- Magnetic coupling provides an energy-efficient thermal shield, minimizing heat transfer to pumped fluid
- Temperature stability and product purity ensured
- Leak-free continuous operation
- IPX5 motor enclosure
- Low condensation
- Zero maintenance
- Long life
- UL certified models



### PERFORMANCE

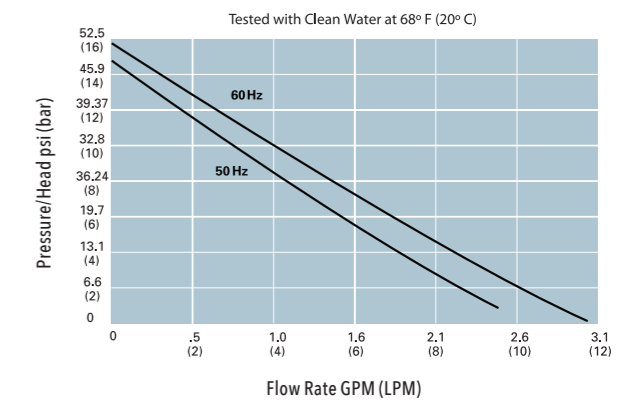

### DIMENSIONAL DRAWINGS

Unless otherwise stated, dimensions are in inches and (mm).

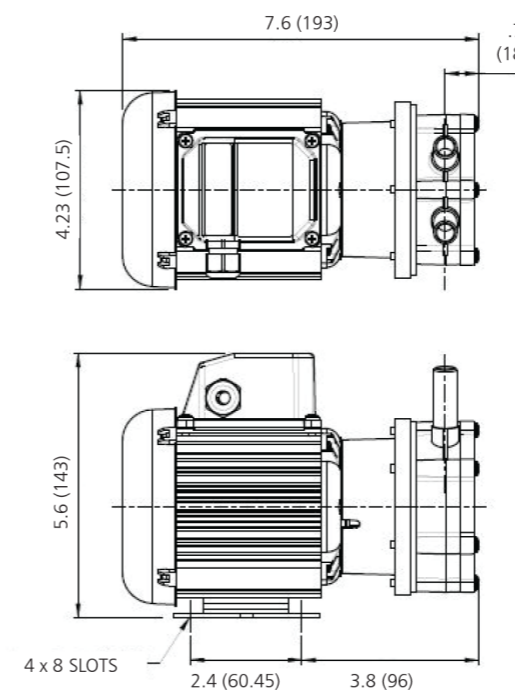

### SPECIFICATIONS

<b>PUMP DESIGN</b>	Magnetically coupled regenerative pump
<b>FLOW RATE (RUNOUT)</b>	50Hz – 2.7 GPM (10.1 LPM) 60Hz – 3 GPM (11.4 LPM)
<b>BODY PRESSURE</b>	87 psi (6 bar) max
<b>CLOSED VALVE HEAD</b>	50Hz – 48' (14.6m) 60Hz – 52' (15.8m)
<b>MOTORS</b>	110V AC; 230V AC
<b>MOTOR OUTPUT</b>	60 watts
<b>PORTS</b>	1/2" (13mm) BSP, plain 0.6" (15mm)
<b>MAX SPECIFIC GRAVITY*</b>	1
<b>TEMPERATURE RANGE</b>	-4°F to +185°F (-20°C to +85°C)
<b>DIMENSIONS</b>	5.6" high x 7.6" long x 3.5" wide (143mm x 193mm x 90mm)
<b>WEIGHT</b>	6.8lb (3.1kg)

\*Assuming maximum viscosity of 30 cp. Refer to Xylem for higher viscosities and specific gravities.

Contact factory for custom models.

# 02 Centrifugal Pumps

MAG DRIVE



## NEMP20/12



For applications requiring safe, leak-free, high head, continuous flow of aggressive chemicals, acids, alkalis, solvents, pure and chilled fluids.

### FEATURES

- Manufactured in chemical resistant thermoplastics – entirely non-metallic
- Multistage versions developed for high head with low flow
- Magnetic couplings provide an energy-efficient thermal shield, minimizing heat transfer to the pumped fluid
- IPX5 standard motor housing
- Deep groove ball bearings
- Variable pump body orientation and mounting foot positions
- UL certified models

### PERFORMANCE

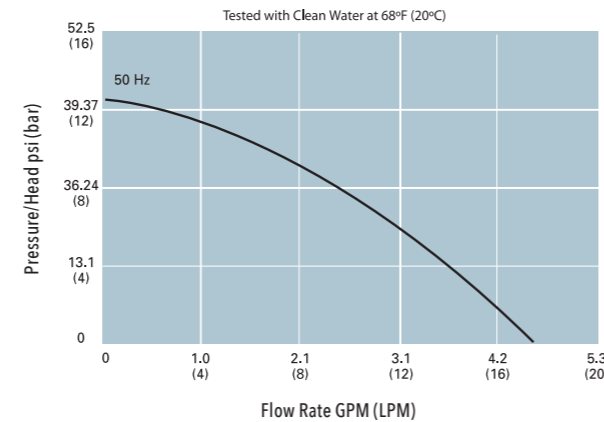

### DIMENSIONAL DRAWINGS

Unless otherwise stated, dimensions are in inches and (mm).

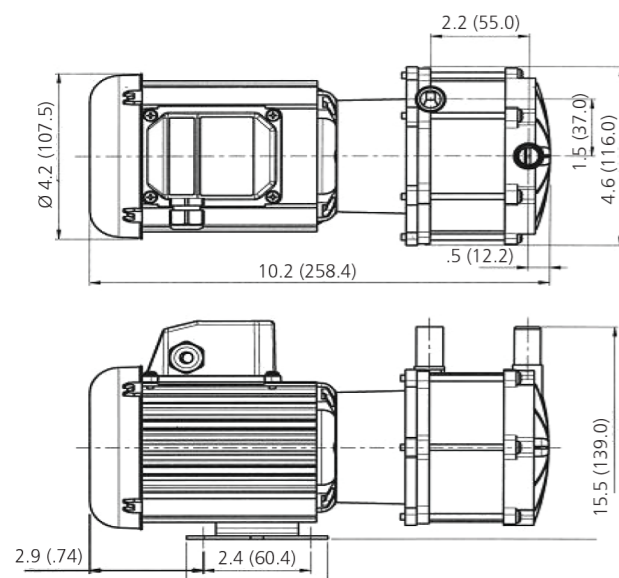

### SPECIFICATIONS

<b>PUMP DESIGN</b>	Multistage magnetically coupled centrifugal pump
<b>FLOW RATE (RUNOUT)</b>	4.6 GPM (17.4 LPM)
<b>BODY PRESSURE</b>	36.3 psi (2.5 bar) max
<b>CLOSED VALVE HEAD</b>	41.6' (12.7m)
<b>MOTORS</b>	100-110V AC, 1Ph, 50/60Hz; 230V AC, 1Ph, 50/60Hz
<b>MOTOR OUTPUT</b>	60 watts
<b>PORTS</b>	3/8" (10mm) BSP, plain 0.6" (15mm), 3/4" (19mm) hose barb
<b>MAX SPECIFIC GRAVITY*</b>	1.2
<b>TEMPERATURE RANGE</b>	-4°F to +185°F (-20°C to +85°C)
<b>DIMENSIONS</b>	5.6" high x 8.5" long x 4.9" wide (143mm x 218mm x 116mm)
<b>WEIGHT</b>	6.6lb (3.0kg)

\*Assuming maximum viscosity of 30 cp. Refer to Xylem for higher viscosities and specific gravities.

Contact factory for custom models.

## NEMP20/18



For applications requiring safe, leak-free, high head, continuous flow of aggressive chemicals, acids, alkalis, solvents, pure and chilled fluids.

### FEATURES

- Manufactured in chemical resistant thermoplastics – entirely non-metallic
- Multistage versions developed for high head with low flow
- Magnetic couplings provide an energy-efficient thermal shield, minimizing heat transfer to the pumped fluid
- IPX5 standard motor housing
- Deep groove ball bearings
- Variable pump body orientation and mounting foot positions
- UL certified models

### PERFORMANCE

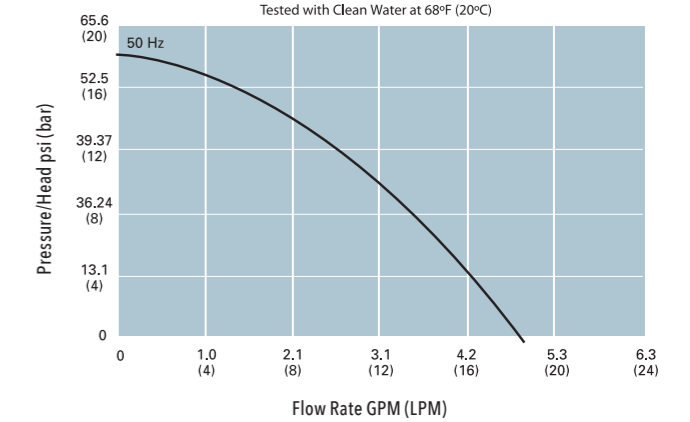

### DIMENSIONAL DRAWINGS

Unless otherwise stated, dimensions are in inches and (mm).

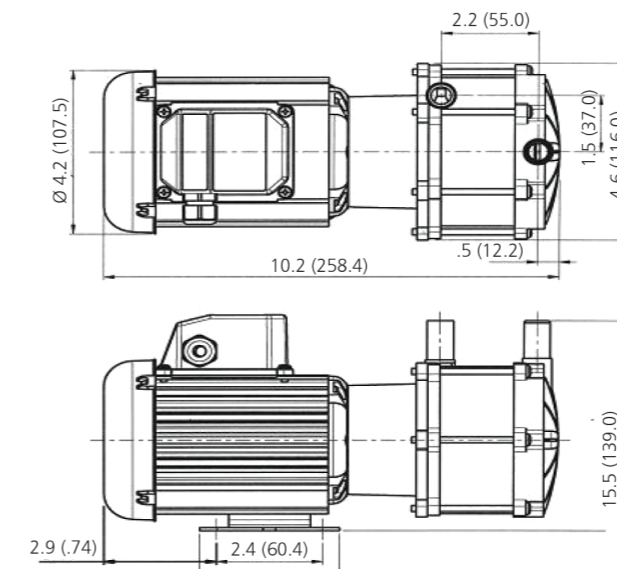

### SPECIFICATIONS

<b>PUMP DESIGN</b>	Multistage magnetically coupled centrifugal pump
<b>FLOW RATE (RUNOUT)</b>	4.9 GPM (18.5 LPM)
<b>BODY PRESSURE</b>	36.3 psi (2.5 bar) max
<b>CLOSED VALVE HEAD</b>	59' (18m)
<b>MOTORS</b>	110V AC, 1Ph, 50Hz; 230V AC, 1Ph, 50/60Hz
<b>MOTOR OUTPUT</b>	90 watts
<b>PORTS</b>	3/8" (10mm) BSP, plain 0.6" (15mm), 3/4" (19mm) hose barb, 3/8" (10mm) NPT
<b>MAX SPECIFIC GRAVITY*</b>	1.2
<b>TEMPERATURE RANGE</b>	-4°F to +185°F (-20°C to +85°C)
<b>DIMENSIONS</b>	5.5" high x 10.2" long x 4.6" wide (139mm x 259mm x 116mm)
<b>WEIGHT</b>	8.4lb (3.8kg)

\*Assuming maximum viscosity of 30 cp. Refer to Xylem for higher viscosities and specific gravities.

Contact factory for custom models.

# 02 Centrifugal Pumps

MAG DRIVE



## NEMP25/5

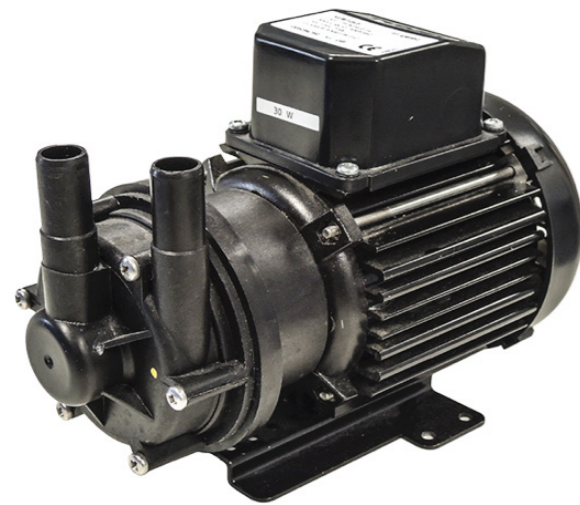

For applications requiring safe, leak-free, continuous flow of aggressive chemicals, acids, alkalis, sterile and chilled fluids.

### FEATURES

- Manufactured in chemical resistant thermoplastics – entirely non-metallic
- Magnetic couplings provide an energy-efficient thermal shield, minimizing heat transfer to the pumped fluid
- IPX5 standard motor housing
- Deep groove ball bearings

### PERFORMANCE

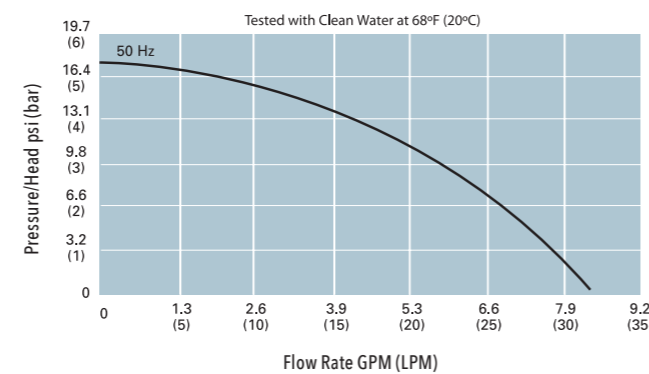

### DIMENSIONAL DRAWINGS

Unless otherwise stated, dimensions are in inches and (mm).

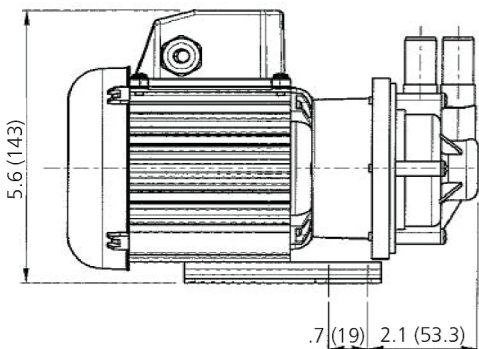
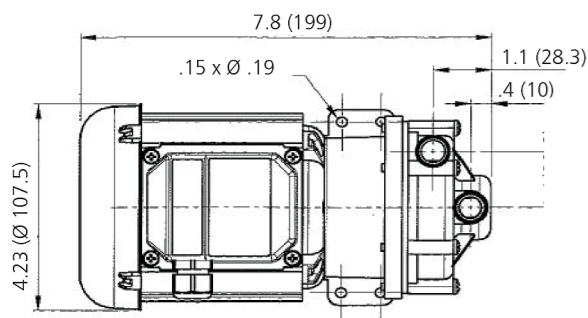

### SPECIFICATIONS

<b>PUMP DESIGN</b>	Magnetically coupled centrifugal pump
<b>FLOW RATE (RUNOUT)</b>	8.5 GPM (32 LPM)
<b>BODY PRESSURE</b>	20.3 psi (1.4 bar) max
<b>CLOSED VALVE HEAD</b>	17.4' (5.3m)
<b>MOTORS</b>	110V AC, 1Ph, 50Hz; 230V AC, 1Ph, 50/60Hz
<b>MOTOR OUTPUT</b>	35 watts
<b>PORTS</b>	Plain 0.6" (15mm), 3/4" (19mm) hose barb, 3/8" (10mm) BSP, 3/8" (10mm) NPT
<b>MAX SPECIFIC GRAVITY*</b>	1.2
<b>TEMPERATURE RANGE</b>	-4°F to +185°F (-20°C to +85°C)
<b>DIMENSIONS</b>	5.6" high x 7.8" long x 4" wide (143mm x 199mm x 102mm)
<b>WEIGHT</b>	5.3lb (2.4kg)

\*Assuming maximum viscosity of 30 cp. Refer to Xylem for higher viscosities and specific gravities.

Contact factory for custom models.

## NEMP40/4



For applications requiring safe, leak-free, continuous flow of aggressive chemicals, acids, alkalis, sterile and chilled fluids.

### FEATURES

- Manufactured in chemical resistant thermoplastics – entirely non-metallic
- Magnetic couplings provide an energy-efficient thermal shield, minimizing heat transfer to the pumped fluid
- IP54 standard motor housing. IP55 version available.
- Deep groove ball bearings
- UL certified models

### PERFORMANCE

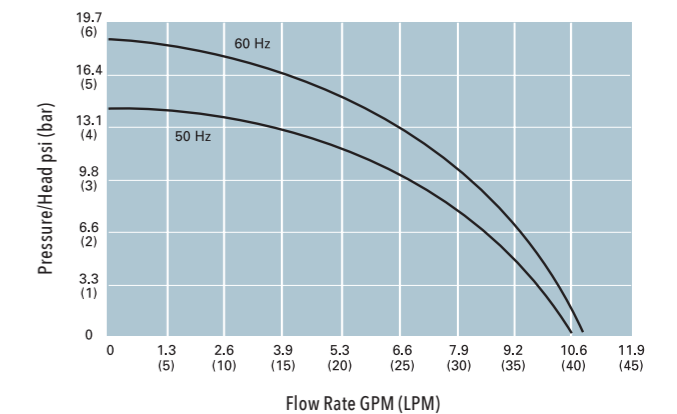

### DIMENSIONAL DRAWINGS

Unless otherwise stated, dimensions are in inches and (mm).

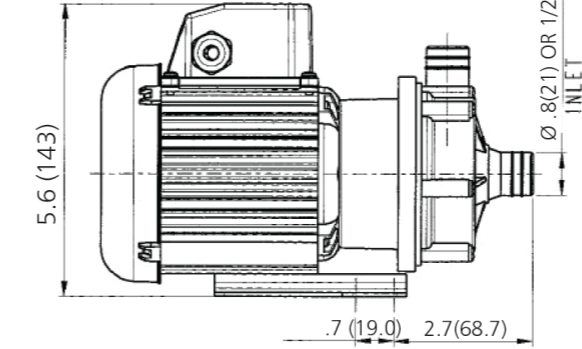
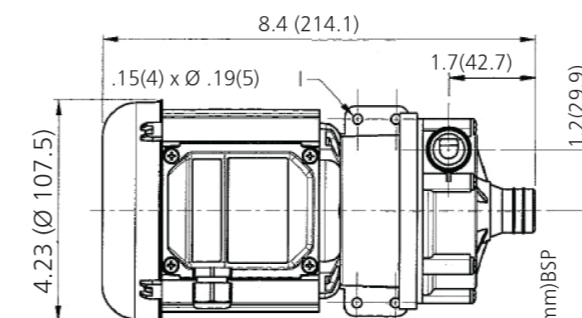

### SPECIFICATIONS

<b>PUMP DESIGN</b>	Magnetically coupled centrifugal pump
<b>FLOW RATE (RUNOUT)</b>	50Hz – 10.6 GPM (40 LPM) 60Hz – 10.8 GPM (41 LPM)
<b>BODY PRESSURE</b>	20.3 psi (1.4 bar) max
<b>CLOSED VALVE HEAD</b>	50Hz – 14.4' (4.4m) 60Hz – 18.7' (5.7m)
<b>MOTORS</b>	110V AC, 1Ph, 50Hz; 230V AC, 1Ph, 50/60Hz
<b>MOTOR OUTPUT</b>	30 watts
<b>PORTS</b>	1/2" (13mm) NPT, plain 0.8" (21mm), 1/2" (13mm) BSP
<b>MAX SPECIFIC GRAVITY*</b>	1.2
<b>TEMPERATURE RANGE</b>	-4°F to +185°F (-20°C to +85°C)
<b>DIMENSIONS</b>	5.6" high x 8.4" long x 4" wide (143mm x 214mm x 102mm)
<b>WEIGHT</b>	5.9lb (2.7kg)

\*Assuming maximum viscosity of 30 cp. Refer to Xylem for higher viscosities and specific gravities.

Contact factory for custom models.

# 02 Centrifugal Pumps

MAG DRIVE

**FLOJET®**

## NEMP40/6



For applications requiring safe, leak-free, continuous flow of aggressive chemicals, acids, alkalis, sterile and chilled fluids.

### FEATURES

- Manufactured in chemical resistant thermoplastics – entirely non-metallic
- Magnetic couplings provide an energy-efficient thermal shield, minimizing heat transfer to the pumped fluid
- IPX5 standard motor housing. IP55 version available.
- Deep groove ball bearings

### PERFORMANCE

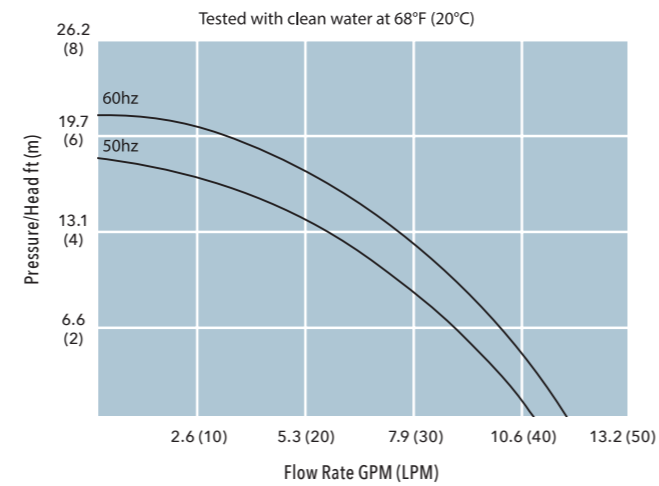

### DIMENSIONAL DRAWINGS

Unless otherwise stated, dimensions are in inches and (mm).

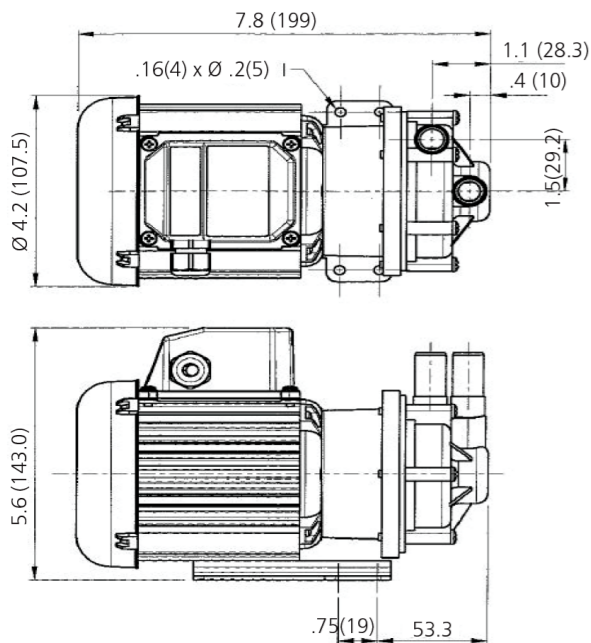

### SPECIFICATIONS

<b>PUMP DESIGN</b>	Magnetically coupled centrifugal pump
<b>FLOW RATE (RUNOUT)</b>	50Hz – 10.6 GPM (40 LPM) 60Hz – 11.4 GPM (43 LPM)
<b>BODY PRESSURE</b>	20.3 psi (1.4 bar) max
<b>CLOSED VALVE HEAD</b>	50Hz – 18.4' (5.6m) 60Hz – 21.3' (6.5m)
<b>MOTORS</b>	110V AC, 1Ph, 50/60Hz; 230V AC, 1Ph, 50/60Hz
<b>MOTOR OUTPUT</b>	60 watts
<b>PORTS</b>	3/4" (19mm) hose barb, 3/8" (10mm) NPT, plain 0.6" (15mm), 3/8" (10mm) BSP
<b>MAX SPECIFIC GRAVITY*</b>	1.2
<b>TEMPERATURE RANGE</b>	-4°F to +185°F (-20°C to +85°C)
<b>DIMENSIONS</b>	5.6" high x 7.9" long x 4" wide (143mm x 200mm x 102mm)
<b>WEIGHT</b>	6.6lb (3.0kg)

\*Assuming maximum viscosity of 30 cp. Refer to Xylem for higher viscosities and specific gravities.

Contact factory for custom models.

## NEMP50/7



For applications requiring safe, leak-free, continuous flow of aggressive chemicals, acids, alkalis, sterile and chilled fluids.

### FEATURES

- Manufactured in chemical resistant thermoplastics – entirely non-metallic
- Magnetic couplings provide an energy-efficient thermal shield, minimizing heat transfer to the pumped fluid
- IPX5 standard motor housing
- Deep groove ball bearings
- UL certified models

### PERFORMANCE

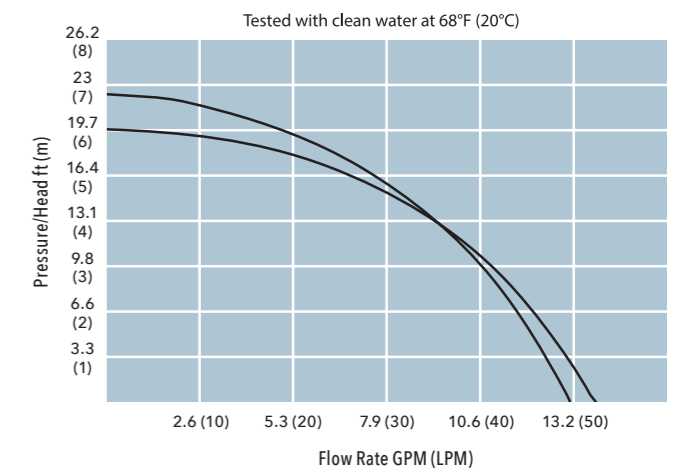

### DIMENSIONAL DRAWINGS

Unless otherwise stated, dimensions are in inches and (mm).

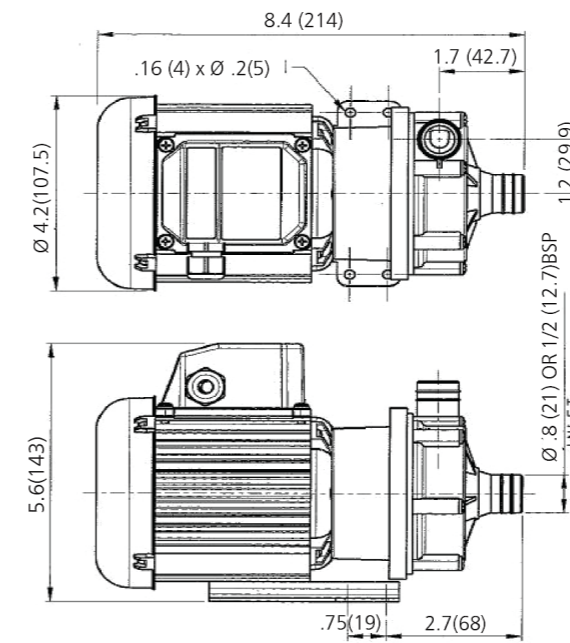

### SPECIFICATIONS

<b>PUMP DESIGN</b>	Magnetically coupled centrifugal pump
<b>FLOW RATE (RUNOUT)</b>	50Hz – 13.2 GPM (50 LPM) 60Hz – 13.7 GPM (52 LPM)
<b>BODY PRESSURE</b>	20.3 psi (1.4 bar) max
<b>CLOSED VALVE HEAD</b>	50Hz – 19.7' (6m) 60Hz – 22.3' (6.8m)
<b>MOTORS</b>	110V AC, 1Ph, 50/60Hz; 230V AC, 1Ph, 50/60Hz
<b>MOTOR OUTPUT</b>	60 watts
<b>PORTS</b>	1/2" (13mm) BSP, plain 0.8" (21mm), 1" (25mm) hose barb, 1/2" (13mm) NPT
<b>MAX SPECIFIC GRAVITY*</b>	1.2
<b>TEMPERATURE RANGE</b>	-4°F to +185°F (-20°C to +85°C)
<b>DIMENSIONS</b>	5.6" high x 8.4" long x 4" wide (143mm x 214mm x 102mm)
<b>WEIGHT</b>	6.8lb (3.1kg)

\*Assuming maximum viscosity of 30 cp. Refer to Xylem for higher viscosities and specific gravities.

Contact factory for custom models.

# 02 Centrifugal Pumps

MAG DRIVE



## NEMP50/11



For applications requiring safe, leak-free, continuous flow of aggressive chemicals, acids, alkalis, sterile and chilled fluids.

### FEATURES

- Manufactured in chemical resistant thermoplastics – entirely non-metallic
- Pump head can be connected in series for high head applications
- Can pump two dissimilar fluids simultaneously
- Magnetic couplings provide an energy-efficient thermal shield, minimizing heat transfer to the pumped fluid
- IP54 standard motor housing. IP55 version available.
- Deep groove ball bearings

### PERFORMANCE

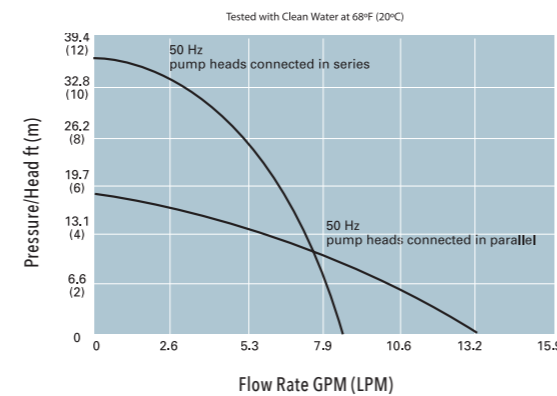

### MODELS

MODEL #	CERTIFICATION	VOLTAGE	PORT DETAILS
406946	CE	230V, 1Ph, 50Hz	3/8" (10mm) BSP male
456903	CE	230V, 1Ph, 50Hz	Plain 0.6" (15mm)

Contact factory for custom models.

### SPECIFICATIONS

<b>PUMP DESIGN</b>	Double-ended magnetically coupled centrifugal pump
<b>FLOW RATE (RUNOUT)</b>	13.2 GPM (50 LPM)
<b>BODY PRESSURE</b>	20.3 psi (1.4 bar) max
<b>CLOSED VALVE HEAD</b>	36.1' (11m)
<b>MOTOR OUTPUT</b>	90 watts
<b>MAX SPECIFIC GRAVITY*</b>	1.2
<b>TEMPERATURE RANGE</b>	-4°F to +185°F (-20°C to +85°C)
<b>DIMENSIONS</b>	5.1" high x 11" long x 5.2" wide (130mm x 280mm x 132mm)
<b>WEIGHT</b>	8.4lb (3.8kg)

\*Assuming maximum viscosity of 30 cp. Refer to Xylem for higher viscosities and specific gravities.

### DIMENSIONAL DRAWINGS

Unless otherwise stated, dimensions are in inches and (mm).

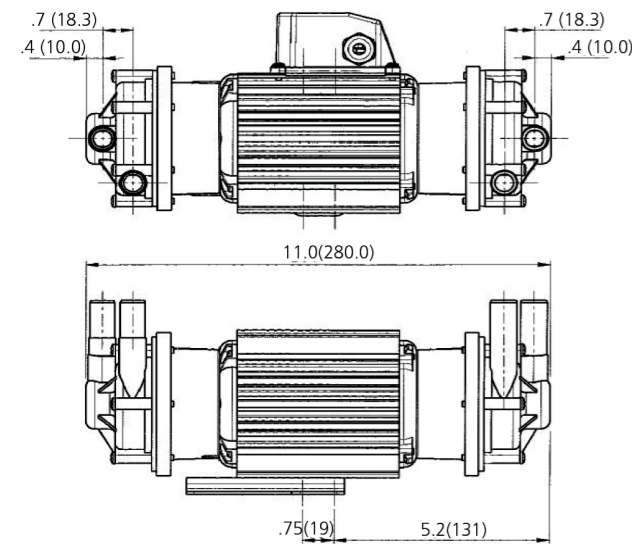

## NEMP50/25



For applications requiring safe, leak-free, continuous flow of aggressive chemicals, acids, alkalis, sterile and chilled fluids.

### FEATURES

- Manufactured in chemical resistant thermoplastics – entirely non-metallic
- Magnetic couplings provide an energy-efficient thermal shield, minimizing heat transfer to the pumped fluids
- Variable pump body orientation
- Compatible with standard pushfit fittings
- IP55 standard motor housing

### PERFORMANCE

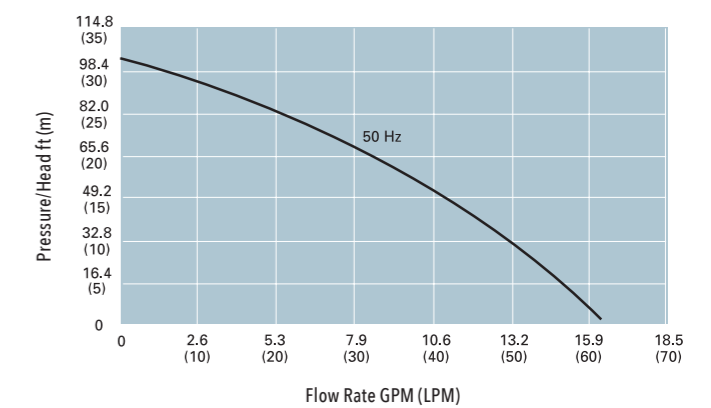

### DIMENSIONAL DRAWINGS

Unless otherwise stated, dimensions are in inches and (mm).

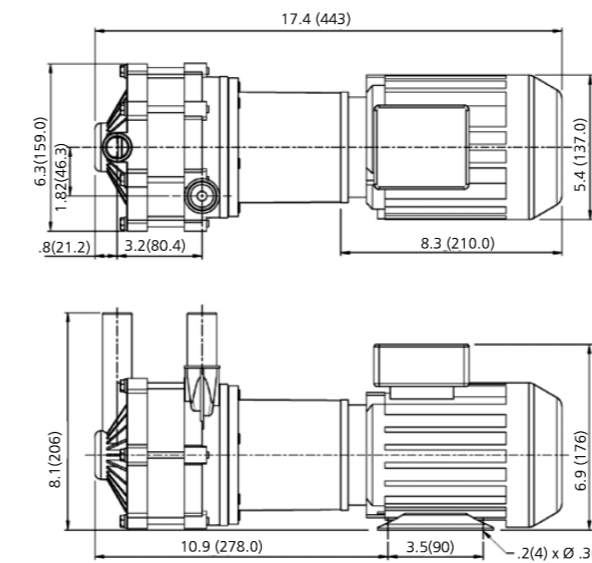

### MODELS

MODEL #	CERTIFICATION	VOLTAGE	PORT DETAILS
048937	CE	230V, 1Ph, 50Hz	Plain 1.1" (28mm)

Contact factory for custom models.

### SPECIFICATIONS

<b>PUMP DESIGN</b>	Multistage magnetically coupled centrifugal pump
<b>FLOW RATE (RUNOUT)</b>	16.2 GPM (61.5 LPM)
<b>BODY PRESSURE</b>	29 psi (2 bar) max
<b>CLOSED VALVE HEAD</b>	103.3' (31.5m)
<b>MOTOR OUTPUT</b>	550 watts
<b>MAX SPECIFIC GRAVITY*</b>	1
<b>TEMPERATURE RANGE</b>	-4°F to +185°F (-20°C to +85°C)
<b>DIMENSIONS</b>	8.1" high x 17.4" long x 6.3" wide (206mm x 443mm x 159mm)
<b>WEIGHT</b>	8.4lb (10.1kg)

\*Assuming maximum viscosity of 30 cp. Refer to Xylem for higher viscosities and specific gravities.

# 02 Centrifugal Pumps

MAG DRIVE

**FLOJET®**

## NEMP60/6



For applications requiring safe, leak-free, continuous flow of aggressive chemicals, acids, alkalis, sterile and chilled fluids.

### FEATURES

- Manufactured in chemical resistant thermoplastics – entirely non-metallic
- Magnetic couplings provide an energy-efficient thermal shield, minimizing heat transfer to the pumped fluid
- IP55 motor standard

### PERFORMANCE

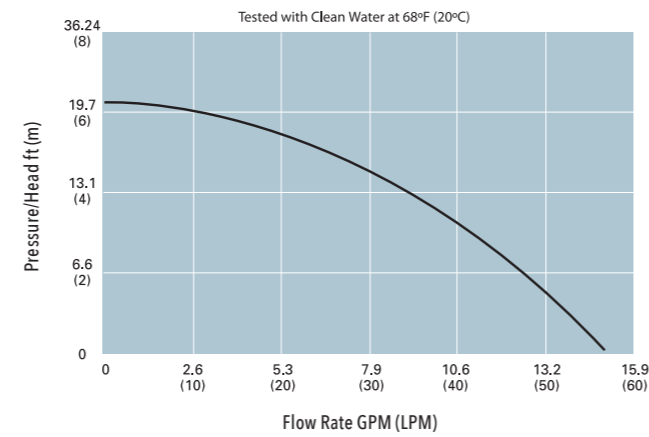

### DIMENSIONAL DRAWINGS

Unless otherwise stated, dimensions are in inches and (mm).

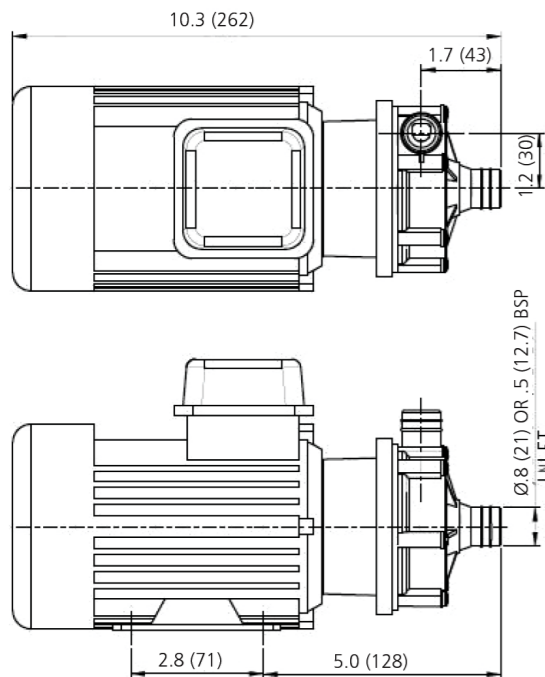

### MODELS

MODEL #	CERTIFICATION	VOLTAGE	PORT DETAILS
018923	CE	400V, 3Ph, 50Hz	Plain 0.8" (21mm)
018924	CE	400V, 3Ph, 50Hz	1/2" (13mm) BSP male

Contact factory for custom models.

### SPECIFICATIONS

<b>PUMP DESIGN</b>	Magnetically coupled centrifugal pump
<b>FLOW RATE (RUNOUT)</b>	15.1 GPM (57 LPM)
<b>BODY PRESSURE</b>	20.3 psi (1.4 bar) max
<b>CLOSED VALVE HEAD</b>	20.3' (6.2m)
<b>MOTOR OUTPUT</b>	90 watts
<b>MAX SPECIFIC GRAVITY*</b>	1.2
<b>TEMPERATURE RANGE</b>	-4°F to +185°F (-20°C to +85°C)
<b>DIMENSIONS</b>	5.7" high x 10.3" long x 4.3" wide (146mm x 262mm x 108mm)
<b>WEIGHT</b>	8.8lb (4.0kg)

\*Assuming maximum viscosity of 30 cp. Refer to Xylem for higher viscosities and specific gravities.

## NEMP80/6



For applications requiring safe, leak-free, continuous flow of aggressive chemicals, acids, alkalis, sterile and chilled fluids.

### FEATURES

- Manufactured in chemical resistant thermoplastics – entirely non-metallic
- Magnetic couplings provide an energy-efficient thermal shield, minimizing heat transfer to the pumped fluid
- IPX5 standard motor housing
- Deep groove ball bearings
- UL certified models

### PERFORMANCE

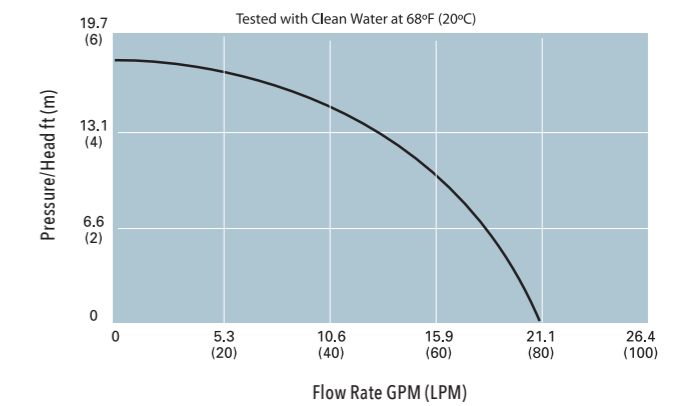

### DIMENSIONAL DRAWINGS

Unless otherwise stated, dimensions are in inches and (mm).

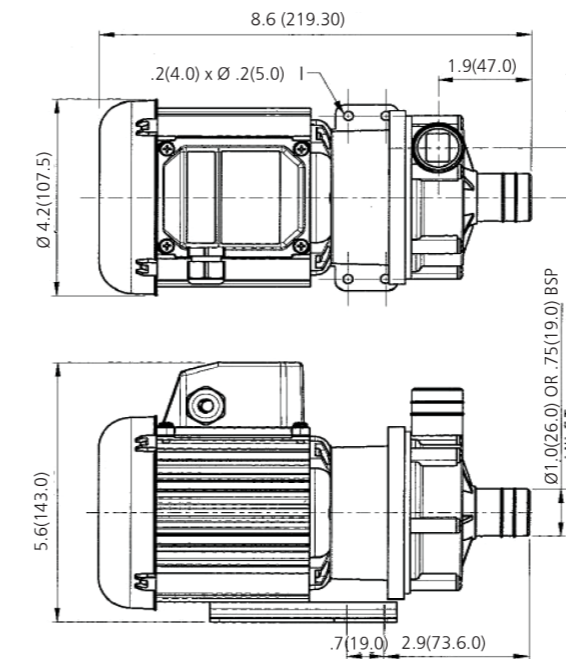

### SPECIFICATIONS

<b>PUMP DESIGN</b>	Magnetically coupled centrifugal pump
<b>FLOW RATE (RUNOUT)</b>	21.1 GPM (80 LPM)
<b>BODY PRESSURE</b>	20.3 psi (1.4 bar) max
<b>CLOSED VALVE HEAD</b>	18' (5.5m)
<b>MOTORS</b>	110V AC, 1Ph, 50/60Hz; 230V AC, 1Ph, 50/60Hz
<b>MOTOR OUTPUT</b>	60 watts
<b>PORTS</b>	Plain 1" (25mm), 3/4" (19mm) BSP, 3/4" (19mm) NPT
<b>MAX SPECIFIC GRAVITY*</b>	1.2
<b>TEMPERATURE RANGE</b>	-4°F to +185°F (-20°C to +85°C)
<b>DIMENSIONS</b>	5.6" high x 8.7" long x 4" wide (143mm x 220mm x 102mm)
<b>WEIGHT</b>	6.8lb (3.1kg)

\*Assuming maximum viscosity of 30 cp. Refer to Xylem for higher viscosities and specific gravities.

Contact factory for custom models.



# 02 Centrifugal Pumps

MAG DRIVE



## NEMP100/6



For heavy duty applications requiring safe, leak-free, continuous flow of aggressive chemicals, acids, solvents, alkalis, sterile and chilled fluids.

### FEATURES

- Manufactured in chemical resistant thermoplastics – entirely non-metallic
- Magnetic couplings provide an energy-efficient thermal shield, minimizing heat transfer to the pumped fluids
- IP55 standard motor housing

### PERFORMANCE

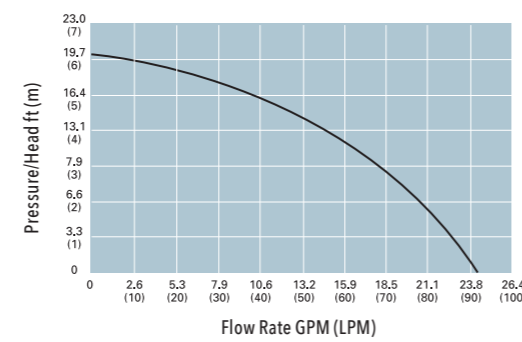

### DIMENSIONAL DRAWINGS

Unless otherwise stated, dimensions are in inches and (mm).

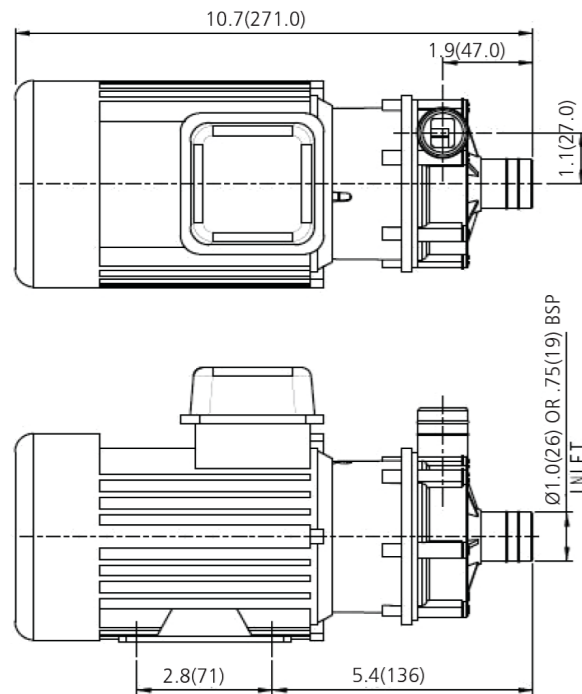

### MODELS

MODEL #	CERTIFICATION	VOLTAGE	PORT DETAILS
028905	CE	400V, 3Ph, 50Hz	Plain 0.8" (21mm)
038925	CE	400V, 3Ph, 50Hz	3/4" (19mm) BSP male

Contact factory for custom models.

### SPECIFICATIONS

<b>PUMP DESIGN</b>	Magnetically coupled centrifugal pump
<b>FLOW RATE (RUNOUT)</b>	15.1 GPM (100 LPM)
<b>BODY PRESSURE</b>	20.3 psi (1.4 bar) max
<b>CLOSED VALVE HEAD</b>	18.7' (5.7m)
<b>MOTOR OUTPUT</b>	90 watts
<b>MAX SPECIFIC GRAVITY*</b>	1.05
<b>TEMPERATURE RANGE</b>	-4°F to +185°F (-20°C to +85°C)
<b>DIMENSIONS</b>	5.7" high x 10.7" long x 4.3" wide (146mm x 271mm x 108mm)
<b>WEIGHT</b>	7.9lb (3.6kg)

\*Assuming maximum viscosity of 30 cp. Refer to Xylem for higher viscosities and specific gravities.

## NEMP120/8



For heavy duty applications requiring safe, leak-free, continuous flow of aggressive chemicals, acids, solvents, alkalis, sterile and chilled fluids.

### FEATURES

- Manufactured in chemical resistant thermoplastics – entirely non-metallic
- Magnetic couplings provide an energy-efficient thermal shield, minimizing heat transfer to the pumped fluids
- IP55 standard motor housing
- High SG versions available

### PERFORMANCE

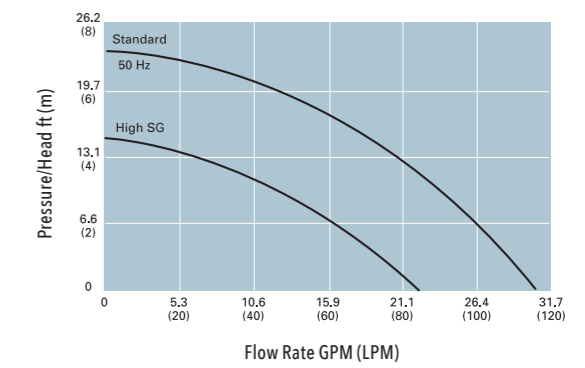

### DIMENSIONAL DRAWINGS

Unless otherwise stated, dimensions are in inches and (mm).

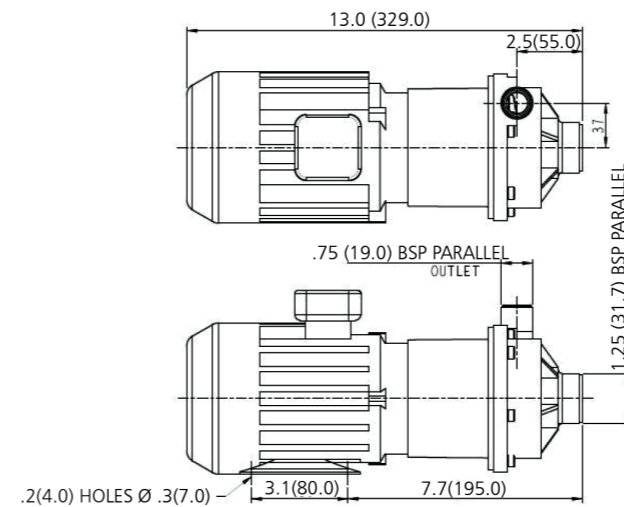

### MODELS

MODEL #	CERTIFICATION	VOLTAGE	PORT DETAILS
028907	CE	230V, 1Ph, 50Hz	1-1/4" (32mm) BSP male (inlet) 3/4" (19mm) BSP male (outlet)
028908	CE	400V, 3Ph, 50Hz	1-1/4" (32mm) BSP male (inlet) 3/4" (19mm) BSP male (outlet)
028939	CE	110V, 1Ph, 60Hz	1-1/4" (32mm) BSP male (inlet) 3/4" (19mm) BSP male (outlet)

Contact factory for custom models.

### SPECIFICATIONS

<b>PUMP DESIGN</b>	Magnetically coupled centrifugal pump
<b>FLOW RATE (RUNOUT)</b>	30.9 GPM (117 LPM)
<b>BODY PRESSURE</b>	24.7 psi (1.7 bar) max
<b>CLOSED VALVE HEAD</b>	26.3' (7.2m)
<b>MOTOR OUTPUT</b>	180 watts (1Ph), 250 watts (3Ph)
<b>MAX SPECIFIC GRAVITY*</b>	1.2
<b>TEMPERATURE RANGE</b>	-4°F to +185°F (-20°C to +85°C)
<b>DIMENSIONS</b>	5.6" high x 13" long x 4.7" wide (141mm x 329mm x 119mm)
<b>WEIGHT</b>	12lb (5.5kg)

\*Assuming maximum viscosity of 30 cp. Refer to Xylem for higher viscosities and specific gravities.

# 02 Centrifugal Pumps

MAG DRIVE



## NEMP160/9



For heavy duty applications requiring safe, leak-free, continuous flow of aggressive chemicals, acids, solvents, alkalis, sterile and chilled fluids.

### FEATURES

- Manufactured in chemical resistant thermoplastics – entirely non-metallic
- Magnetic couplings provide an energy-efficient thermal shield, minimizing heat transfer to the pumped fluids
- IP55 standard motor housing
- High SG version available
- PVDF versions available

### PERFORMANCE

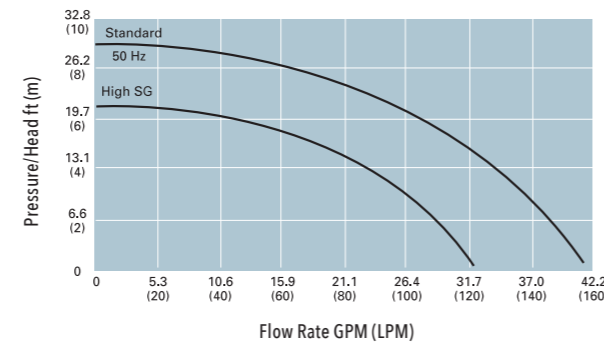

### MODELS

MODEL #	CERTIFICATION	VOLTAGE	PORT DETAILS
028911	CE	230V, 1Ph, 50Hz	1-1/4" (32mm) BSP male (inlet) 3/4" (19mm) BSP male (outlet)
028912	CE	400V, 3Ph, 50Hz	1-1/4" (32mm) BSP male (inlet) 3/4" (19mm) BSP male (outlet)
028941	CE	110V, 1Ph, 60Hz	1-1/4" (32mm) BSP male (inlet) 3/4" (19mm) BSP male (outlet)

Contact factory for custom models.

### SPECIFICATIONS

<b>PUMP DESIGN</b>	Magnetically coupled centrifugal pump
<b>FLOW RATE (RUNOUT)</b>	41.7 GPM (158 LPM)
<b>BODY PRESSURE</b>	24.7 psi (1.7 bar) max
<b>CLOSED VALVE HEAD</b>	28.9' (8.8m)
<b>MOTOR OUTPUT</b>	180 watts (1Ph), 250 watts (3Ph)
<b>MAX SPECIFIC GRAVITY*</b>	1.2
<b>TEMPERATURE RANGE</b>	-4°F to +185°F (-20°C to +85°C)
<b>DIMENSIONS</b>	5.6" high x 12.9" long x 4.7" wide (141mm x 327mm x 119mm)
<b>WEIGHT</b>	12.3lb (5.6kg)

\*Assuming maximum viscosity of 30 cp. Refer to Xylem for higher viscosities and specific gravities.

### DIMENSIONAL DRAWINGS

Unless otherwise stated, dimensions are in inches and (mm).

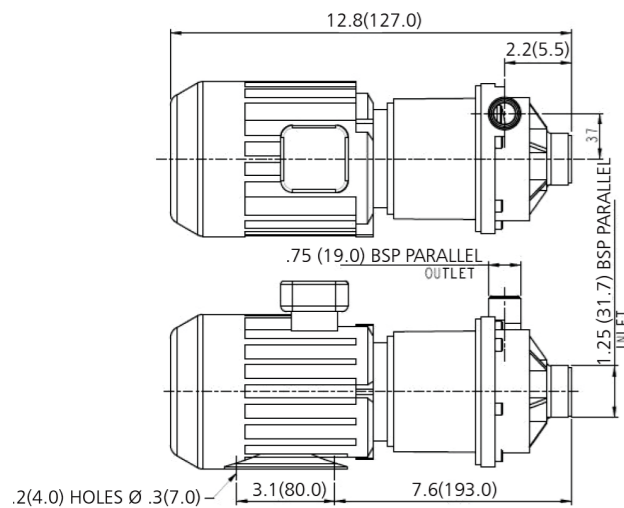

## NEMP200/12



For heavy duty applications requiring safe, leak-free, continuous flow of aggressive chemicals, acids, solvents, alkalis, sterile and chilled fluids.

### FEATURES

- Manufactured in chemical resistant thermoplastics – entirely non-metallic
- Magnetic couplings provide an energy-efficient thermal shield, minimizing heat transfer to the pumped fluids
- IP55 standard motor housing
- High SG version available
- PVDF versions available

### PERFORMANCE

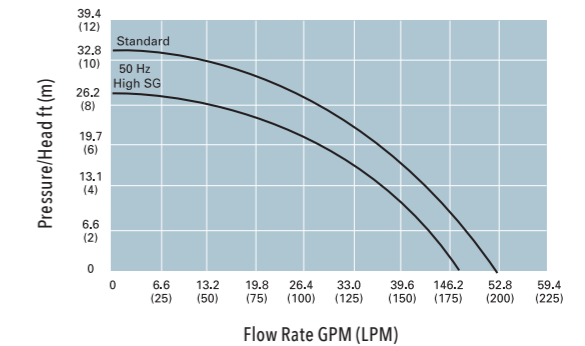

### MODELS

MODEL #	CERTIFICATION	VOLTAGE	PORT DETAILS
028915	CE	230V, 1Ph, 50Hz	1-1/2" (38mm) BSP male (inlet) 1" (25mm) BSP male (outlet)
028916	CE	400V, 3Ph, 50Hz	1-1/2" (38mm) BSP male (inlet) 1" (25mm) BSP male (outlet)
028943	CE	110V, 1Ph, 60Hz	1-1/2" (38mm) BSP male (inlet) 1" (25mm) BSP male (outlet)

Contact factory for custom models.

### SPECIFICATIONS

<b>PUMP DESIGN</b>	Magnetically coupled centrifugal pump
<b>FLOW RATE (RUNOUT)</b>	52.8 GPM (200 LPM)
<b>BODY PRESSURE</b>	29 psi (2 bar) max
<b>CLOSED VALVE HEAD</b>	34.4' (10.5m)
<b>MOTOR OUTPUT</b>	550 watts
<b>MAX SPECIFIC GRAVITY*</b>	1.2
<b>TEMPERATURE RANGE</b>	-4°F to +185°F (-20°C to +85°C)
<b>DIMENSIONS</b>	6.7" high x 16.5" long x 4.9" wide (171mm x 418mm x 125mm)
<b>WEIGHT</b>	21.2lb (9.6kg)

\*Assuming maximum viscosity of 30 cp. Refer to Xylem for higher viscosities and specific gravities.

### DIMENSIONAL DRAWINGS

Unless otherwise stated, dimensions are in inches and (mm).

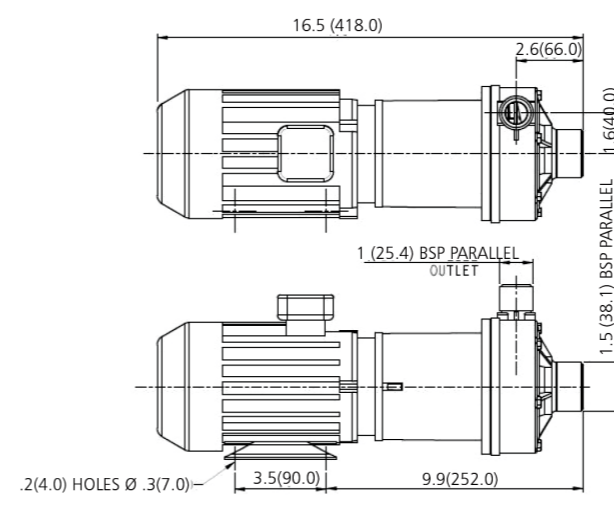

# 02 Centrifugal Pumps

MAG DRIVE



## NEMP300/20



For heavy duty applications requiring safe, leak-free, continuous flow of aggressive chemicals, acids, solvents, alkalis, sterile and chilled fluids.

### FEATURES

- Manufactured in chemical resistant thermoplastics – entirely non-metallic
- Magnetic couplings provide an energy-efficient thermal shield, minimizing heat transfer to the pumped fluids
- IP55 standard motor housing
- High SG version available
- PVDF versions available

### PERFORMANCE

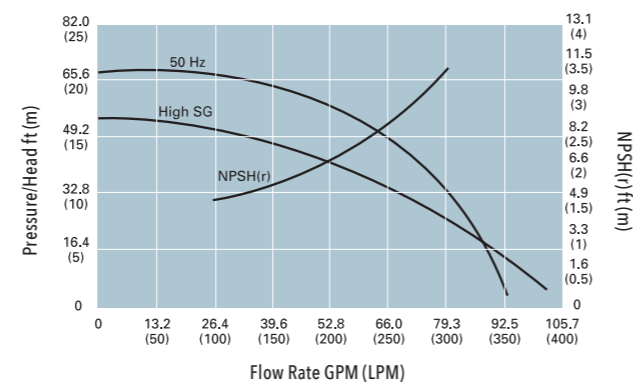

### DIMENSIONAL DRAWINGS

Unless otherwise stated, dimensions are in inches and (mm).

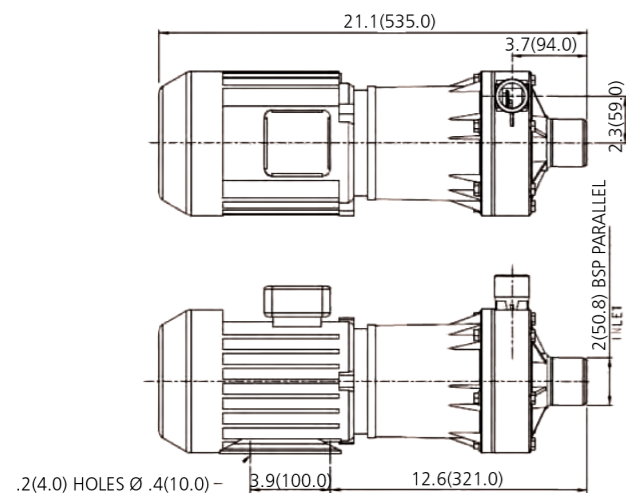

### MODELS

MODEL #	CERTIFICATION	VOLTAGE	PORT DETAILS
028919	CE	230V, 1Ph, 50Hz	2" (51mm) BSP male (inlet) 1-1/4" (32mm) BSP male (outlet)
028920	CE	400V, 3Ph, 50Hz	2" (51mm) BSP male (inlet) 1-1/4" (32mm) BSP male (outlet)
028945	CE	110V, 1Ph, 60Hz	2" (51mm) BSP male (inlet) 1-1/4" (32mm) BSP male (outlet)

Contact factory for custom models.

### SPECIFICATIONS

<b>PUMP DESIGN</b>	Magnetically coupled centrifugal pump
<b>FLOW RATE (RUNOUT)</b>	92.5 GPM (350 LPM)
<b>BODY PRESSURE</b>	43.5 psi (3 bar) max
<b>CLOSED VALVE HEAD</b>	68.9' (21m)
<b>MOTOR OUTPUT</b>	1500 watts
<b>MAX SPECIFIC GRAVITY*</b>	1.2
<b>TEMPERATURE RANGE</b>	-4°F to +185°F (-20°C to +85°C)
<b>DIMENSIONS</b>	8.7" high x 21.1" long x 6.9" wide (222mm x 535mm x 174mm)
<b>WEIGHT</b>	39.7lb (18kg)

\*Assuming maximum viscosity of 30 cp. Refer to Xylem for higher viscosities and specific gravities.

## NEMP500/20



For heavy duty applications requiring safe, leak-free, continuous flow of aggressive chemicals, acids, solvents, alkalis, sterile and chilled fluids.

### FEATURES

- Manufactured in chemical resistant thermoplastics – entirely non-metallic
- Magnetic couplings provide an energy-efficient thermal shield, minimizing heat transfer to the pumped fluids
- IP55 standard motor housing
- High SG version built to order
- PVDF versions available

### PERFORMANCE

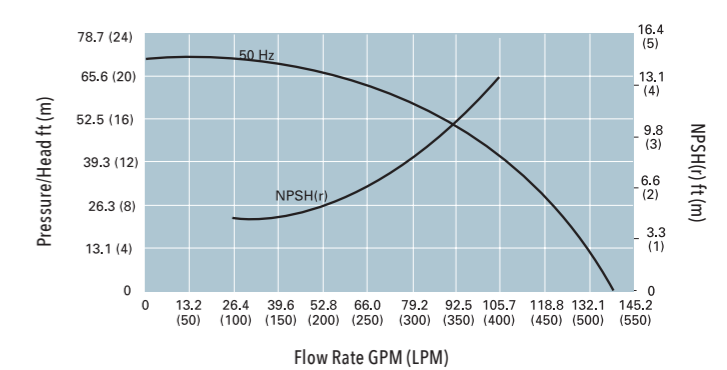

### DIMENSIONAL DRAWINGS

Unless otherwise stated, dimensions are in inches and (mm).

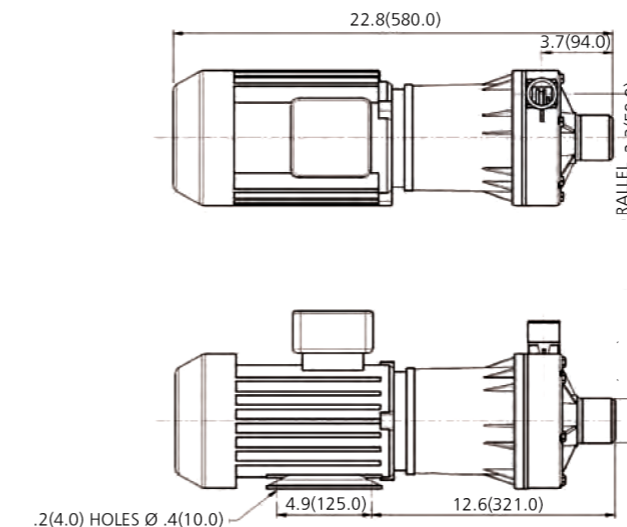

### MODELS

MODEL #	CERTIFICATION	VOLTAGE	PORT DETAILS
028995	CE	400V, 3Ph, 50Hz	2" (51mm) BSP male (inlet) 1-1/4" (32mm) BSP male (outlet)
048941	CE	110V, 1Ph, 50Hz	2" (51mm) BSP male (inlet) 1-1/4" (32mm) BSP male (outlet)

Contact factory for custom models.

### SPECIFICATIONS

<b>PUMP DESIGN</b>	Magnetically coupled centrifugal pump
<b>FLOW RATE (RUNOUT)</b>	138.7 GPM (525 LPM)
<b>BODY PRESSURE</b>	43.5 psi (3 bar) max
<b>CLOSED VALVE HEAD</b>	71.2' (21.7m)
<b>MOTOR OUTPUT</b>	2.2 kW (standard) 3.0 kW (high SG)
<b>MAX SPECIFIC GRAVITY*</b>	1.2
<b>TEMPERATURE RANGE</b>	-4°F to +185°F (-20°C to +85°C)
<b>DIMENSIONS</b>	9.3" high x 22.8" long x 6.9" wide (235mm x 580mm x 175mm)
<b>WEIGHT</b>	45.4lb (20.6kg)

\*Assuming maximum viscosity of 30 cp. Refer to Xylem for higher viscosities and specific gravities.

# 02 Centrifugal Pumps

MAG DRIVE



## NEMP800/30



For heavy duty applications requiring safe, leak-free, continuous flow of aggressive chemicals, acids, solvents, alkalis, sterile and chilled fluids.

### FEATURES

- Manufactured in chemical resistant thermoplastics – entirely non-metallic
- Magnetic couplings provide an energy-efficient thermal shield, minimizing heat transfer to the pumped fluids
- IP55 standard motor housing
- High SG version built to order
- PVDF versions available

### PERFORMANCE

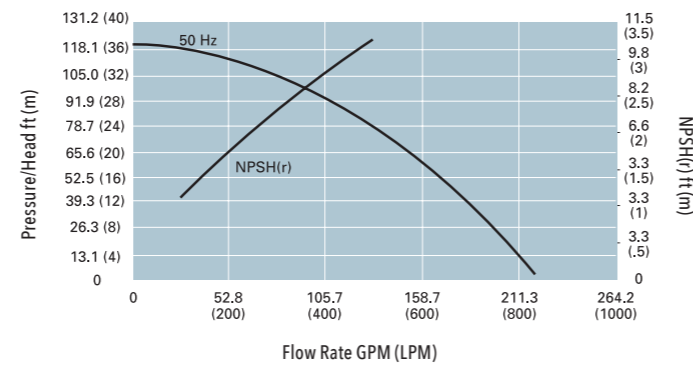

### DIMENSIONAL DRAWINGS

Unless otherwise stated, dimensions are in inches and (mm).

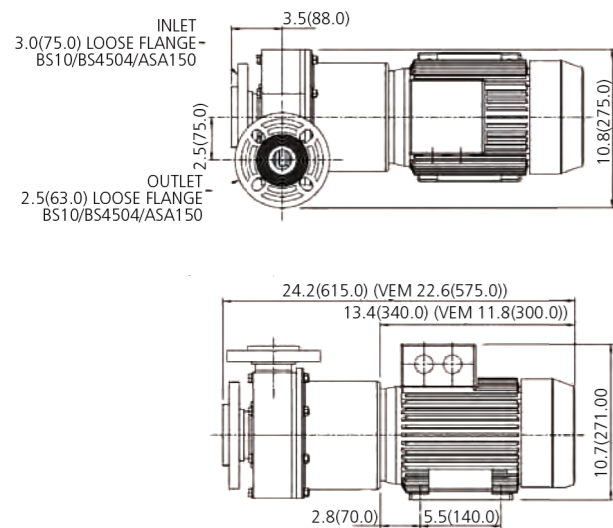

### MODELS

MODEL #	CERTIFICATION	VOLTAGE	PORT DETAILS
048911	CE	400V, 3Ph, 50Hz	3.0" (75mm) flange (inlet) 2.5" (63mm) flange (outlet)

Contact factory for custom models.

### SPECIFICATIONS

<b>PUMP DESIGN</b>	Magnetically coupled centrifugal pump
<b>FLOW RATE (RUNOUT)</b>	219.5 GPM (830 LPM)
<b>BODY PRESSURE</b>	43.5 psi (3 bar) max
<b>CLOSED VALVE HEAD</b>	121.4' (37m)
<b>MOTOR OUTPUT</b>	4 kW
<b>MAX SPECIFIC GRAVITY*</b>	1.2
<b>TEMPERATURE RANGE</b>	-4°F to +185°F (-20°C to +85°C)
<b>DIMENSIONS</b>	10.7" (VEM - 10.6") high x 24.2" (VEM - 22.6") long x 10.8" wide (271mm [VEM - 268mm] x 615mm [VEM - 575mm] x 275mm)
<b>WEIGHT</b>	94.8lb (43kg)

\*Assuming maximum viscosity of 30 cp. Refer to Xylem for higher viscosities and specific gravities.

## NDP14/2



For continuous transfer/recirculation of aggressive chemicals, chilled water, pure or precious liquids, in photographic, reprographic, X-ray and industrial processing equipment, particularly where space is limited.

### FEATURES

- Manufactured in chemical resistant thermoplastics – entirely non-metallic
- Magnetic couplings provide an energy-efficient thermal shield, minimizing heat transfer to pumped fluids
- Leak free continuous operation
- Drip-proof IP22 motor housing
- Low maintenance

### PERFORMANCE

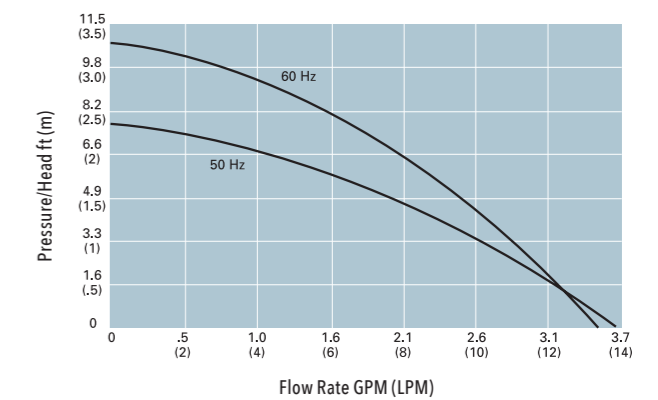

### DIMENSIONAL DRAWINGS

Unless otherwise stated, dimensions are in inches and (mm).

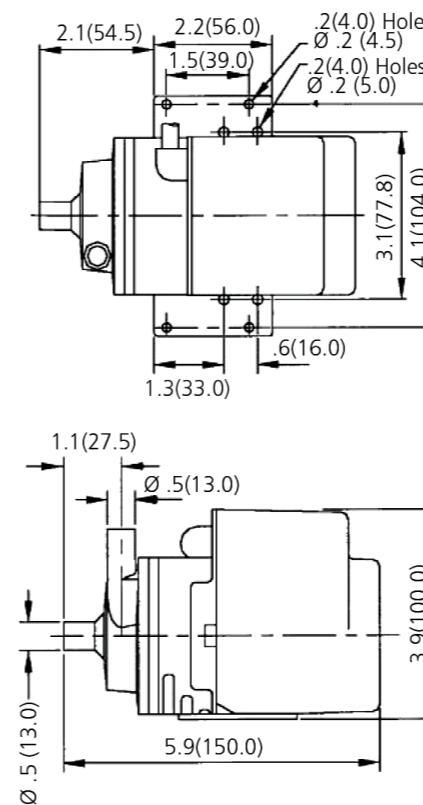

### SPECIFICATIONS

<b>PUMP DESIGN</b>	Magnetically coupled centrifugal pump
<b>FLOW RATE (RUNOUT)</b>	50Hz - 3.65 GPM (13.8 LPM) 60Hz - 3.57 GPM (13.5 LPM)
<b>BODY PRESSURE</b>	20.3 psi (1.4 bar) max
<b>CLOSED VALVE HEAD</b>	50Hz - 7.5' (2.3m) 60Hz - 10.8' (3.3m)
<b>MOTORS</b>	110V AC, 1Ph, 50/60Hz; 230V AC, 1Ph, 50/60Hz
<b>MOTOR OUTPUT</b>	10 watts
<b>PORTS</b>	Plain 1/2" (13mm), 1/4" (6mm) BSP
<b>MAX SPECIFIC GRAVITY*</b>	1.2
<b>TEMPERATURE RANGE</b>	-4°F to +185°F (-20°C to +85°C)
<b>DIMENSIONS</b>	3.9" high x 5.9" long x 4.4" wide (100mm x 150mm x 112mm)
<b>WEIGHT</b>	3.7lb (1.7kg)

\*Assuming maximum viscosity of 30 cp. Refer to Xylem for higher viscosities and specific gravities.

Contact factory for custom models.

# 02 Centrifugal Pumps

MAG DRIVE



## NDP25/2



For continuous transfer/recirculation of aggressive chemicals, chilled water, pure or precious liquids, in photographic, reprographic, X-ray and industrial processing equipment, particularly where space is limited.

### FEATURES

- Manufactured in chemical resistant thermoplastics – entirely non-metallic
- Magnetic couplings provide an energy-efficient thermal shield, minimizing heat transfer to pumped fluids
- Leak free continuous operation
- Drip-proof IP22 motor housing
- Low maintenance

### PERFORMANCE

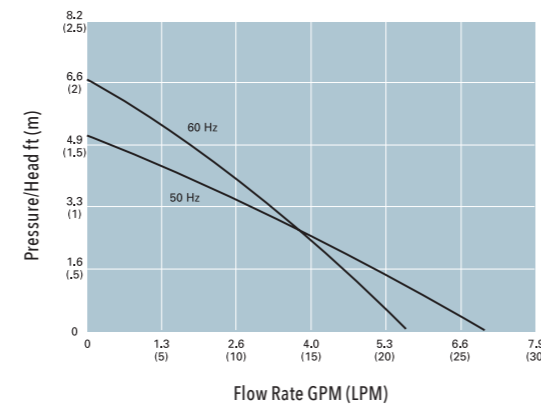

### DIMENSIONAL DRAWINGS

Unless otherwise stated, dimensions are in inches and (mm).

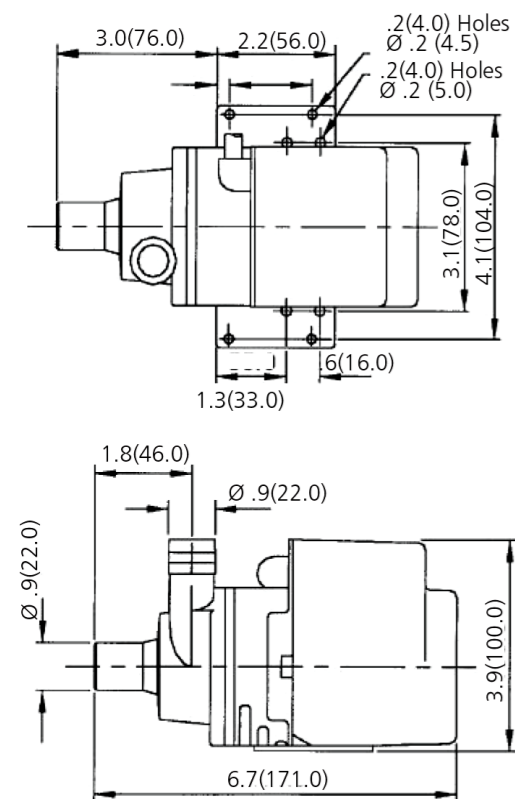

### MODELS

MODEL #	CERTIFICATION	VOLTAGE	PORT DETAILS
123927	CE	230V, 1Ph, 50Hz	Plain 0.9" (22mm)
133923	CE	230V, 1Ph, 50Hz	1/2" (13mm) BSP

Contact factory for custom models.

### SPECIFICATIONS

<b>PUMP DESIGN</b>	Magnetically coupled centrifugal pump
<b>FLOW RATE (RUNOUT)</b>	50Hz – 7.1 GPM (27 LPM) 60Hz – 5.5 GPM (21 LPM)
<b>BODY PRESSURE</b>	20.3 psi (1.4 bar) max
<b>CLOSED VALVE HEAD</b>	50Hz – 5.2' (1.6m) 60Hz – 6.9' (2.1m)
<b>MOTOR OUTPUT</b>	10 watts
<b>MAX SPECIFIC GRAVITY*</b>	1.2
<b>TEMPERATURE RANGE</b>	-4°F to +185°F (-20°C to +85°C)
<b>DIMENSIONS</b>	3.9" high x 6.7" long x 4.4" wide (100mm x 171mm x 112mm)
<b>WEIGHT</b>	4lb (1.8kg)

\*Assuming maximum viscosity of 30 cp. Refer to Xylem for higher viscosities and specific gravities.

## NDP25/4



For continuous transfer/recirculation of aggressive chemicals, chilled water, pure or precious liquids, in photographic, reprographic, X-ray and industrial processing equipment, particularly where space is limited.

### FEATURES

- Manufactured in chemical resistant thermoplastics – entirely non-metallic
- Magnetic couplings provide an energy-efficient thermal shield, minimizing heat transfer to pumped fluids
- Leak free continuous operation
- Drip-proof IP22 motor housing
- Low maintenance
- UL certified models

### PERFORMANCE

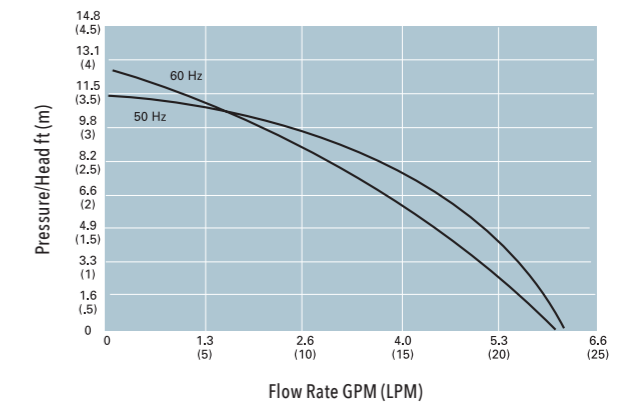

### DIMENSIONAL DRAWINGS

Unless otherwise stated, dimensions are in inches and (mm).

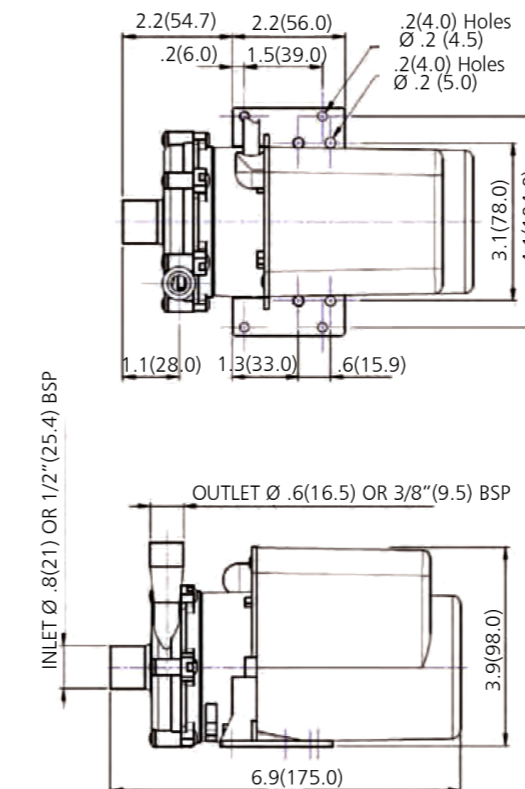

### SPECIFICATIONS

<b>PUMP DESIGN</b>	Magnetically coupled centrifugal pump
<b>FLOW RATE (RUNOUT)</b>	50Hz – 5.9 GPM (22.5 LPM) 60Hz – 6.1 GPM (23 LPM)
<b>BODY PRESSURE</b>	29 psi (2 bar) max
<b>CLOSED VALVE HEAD</b>	50Hz – 11.5' (3.5m) 60Hz – 12.5' (3.8m)
<b>MOTORS</b>	110V AC, 1Ph, 60Hz; 230V AC, 1Ph, 50/60Hz
<b>MOTOR OUTPUT</b>	18 watts
<b>PORTS</b>	Plain 0.8" (21mm) inlet, 0.6" (15mm) outlet; 1/2" (13mm) BSP inlet, 3/8" (10mm) BSP outlet; 1/2" (13mm) NPT inlet, 3/4" (19mm) NPT outlet
<b>MAX SPECIFIC GRAVITY*</b>	1
<b>TEMPERATURE RANGE</b>	-4°F to +185°F (-20°C to +85°C)
<b>DIMENSIONS</b>	4" high x 7.3" long x 4.4" wide (101mm x 185mm x 112mm)
<b>WEIGHT</b>	4.6lb (2.1kg)

\*Assuming maximum viscosity of 30 cp. Refer to Xylem for higher viscosities and specific gravities.

Contact factory for custom models.

# 02 Centrifugal Pumps

MAG DRIVE

**FLOJET®**

## NDP35/3



For continuous transfer/recirculation of aggressive chemicals, chilled water, pure or precious liquids, in photographic, reprographic, X-ray and industrial processing equipment, particularly where space is limited.

### FEATURES

- Manufactured in chemical resistant thermoplastics – entirely non-metallic
- Magnetic couplings provide an energy-efficient thermal shield, minimizing heat transfer to pumped fluids
- Leak free continuous operation
- Drip-proof IP22 motor housing
- Low maintenance

### PERFORMANCE

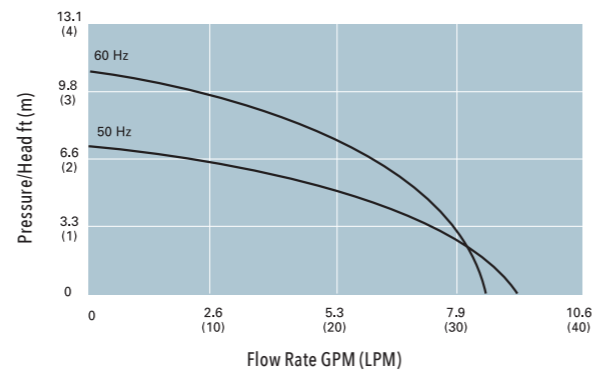

### DIMENSIONAL DRAWINGS

Unless otherwise stated, dimensions are in inches and (mm).

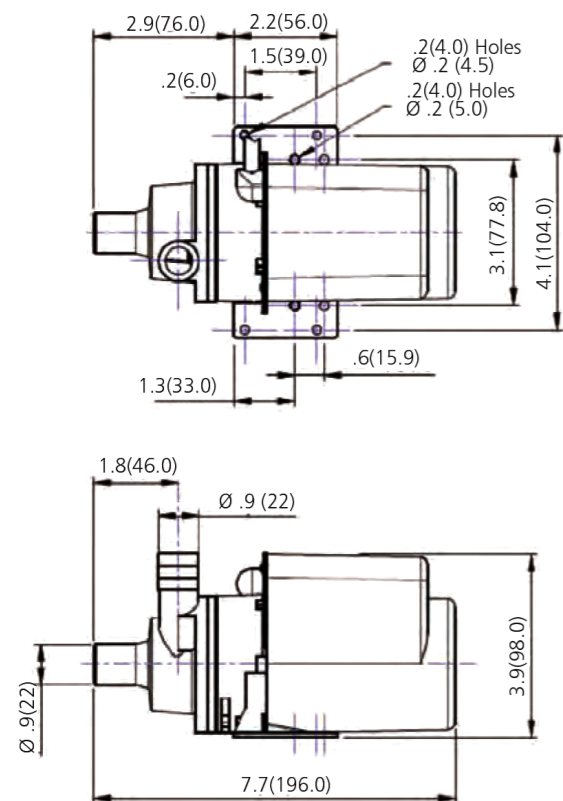

### SPECIFICATIONS

<b>PUMP DESIGN</b>	Magnetically coupled centrifugal pump
<b>FLOW RATE (RUNOUT)</b>	50Hz – 9.2 GPM (35 LPM) 60Hz – 8.7 GPM (33 LPM)
<b>BODY PRESSURE</b>	20.3 psi (1.4 bar) max
<b>CLOSED VALVE HEAD</b>	50Hz – 7.2' (2.2m) 60Hz – 10.8' (3.3m)
<b>MOTORS</b>	110V AC, 1Ph, 50/60Hz; 230V AC, 1Ph, 50/60Hz
<b>MOTOR OUTPUT</b>	18 watts
<b>PORTS</b>	Plain 0.8" (21mm) 1/2" (13mm) NPT
<b>MAX SPECIFIC GRAVITY*</b>	1
<b>TEMPERATURE RANGE</b>	-4°F to +185°F (-20°C to +85°C)
<b>DIMENSIONS</b>	3.9" high x 7.7" long x 4.4" wide (98mm x 196mm x 112.5mm)
<b>WEIGHT</b>	5.1lb (2.3kg)

\*Assuming maximum viscosity of 30 cp. Refer to Xylem for higher viscosities and specific gravities.

Contact factory for custom models.

## DC15/5



Designed for hot and cold drink vending, water circulation, recirculation and cooling duties in beverage, laboratory, agricultural, print, photographic and industrial processing applications, and other short-time-rated applications.

12 volt and 24 volt versions to suit vehicular applications.

### FEATURES

- Magnetically coupled, sealless leak-free design
- Pump body orientation easily altered to suit installations
- Variable mounting foot positions
- Lifts to 16.4' (5m)

### PERFORMANCE

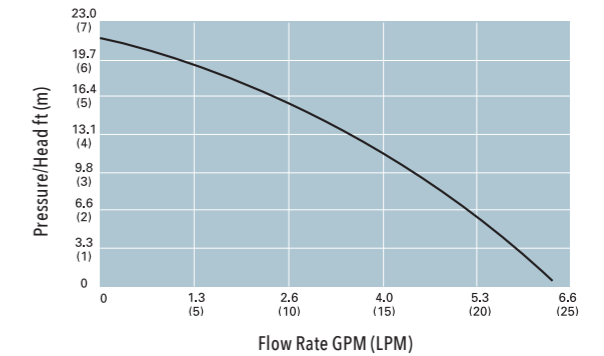

### DIMENSIONAL DRAWINGS

Unless otherwise stated, dimensions are in inches and (mm).

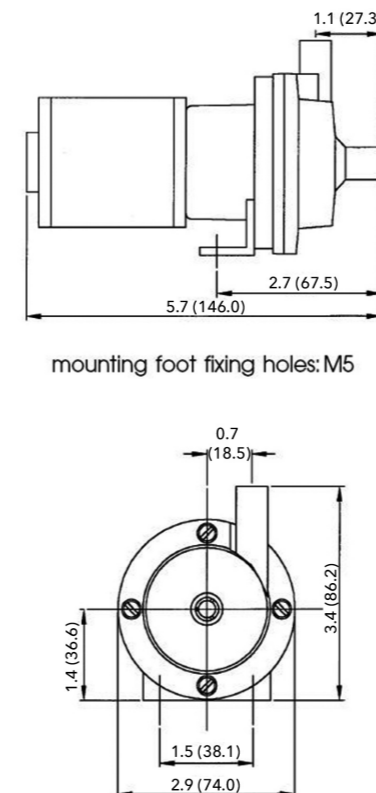

### MODELS

MODEL #	CERTIFICATION	DESCRIPTION	PORT DETAILS
013950	CE	12V DC	Plain 1/2" (13mm)
033944	CE	24V DC	Plain 1/2" (13mm)

Contact factory for custom models.

### SPECIFICATIONS

<b>PUMP DESIGN</b>	Magnetically coupled centrifugal pump
<b>FLOW RATE (RUNOUT)</b>	6.1 GPM (23.0 LPM)
<b>BODY PRESSURE</b>	20.3 psi (1.4 bar) max
<b>CLOSED VALVE HEAD</b>	21.3' (6.5m)
<b>MOTOR OUTPUT</b>	25 watts
<b>MAX SPECIFIC GRAVITY*</b>	1
<b>TEMPERATURE RANGE</b>	-4°F to +185°F (-20°C to +85°C)
<b>DIMENSIONS</b>	3.4" high x 5.7" long x 2.9" wide (86mm x 146mm x 74mm)
<b>WEIGHT</b>	1.5lb (0.7kg)

\*Assuming maximum viscosity of 30 cp. Refer to Xylem for higher viscosities and specific gravities.

# 02 Centrifugal Pumps

MAG DRIVE



## DC30/5



Designed for hot and cold drink vending, water circulation, recirculation and cooling duties in beverage, laboratory, agricultural, print, photographic and industrial processing applications, and other short-time-rated applications.

12 volt and 24 volt versions to suit vehicular applications.

### FEATURES

- Magnetically coupled, sealless leak-free design
- Pump body orientation easily altered to suit installations
- Variable mounting foot positions
- Lifts to 16.4' (5m)

### PERFORMANCE

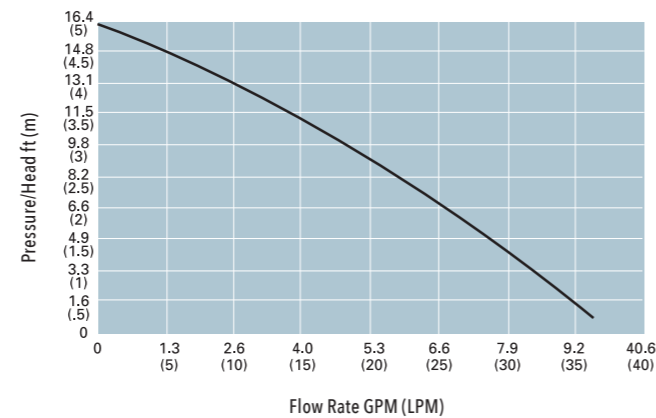

### MODELS

MODEL #	CERTIFICATION	DESCRIPTION	PORT DETAILS
013948	CE	12V DC	Plain 0.8" (21mm)
033982	CE	24V DC	Plain 0.8" (21mm)

Contact factory for custom models.

### SPECIFICATIONS

<b>PUMP DESIGN</b>	Magnetically coupled centrifugal pump
<b>FLOW RATE (RUNOUT)</b>	9.2 GPM (35 LPM)
<b>BODY PRESSURE</b>	20.3 psi (1.4 bar) max
<b>CLOSED VALVE HEAD</b>	16.4' (5.0m)
<b>MOTOR OUTPUT</b>	25 watts
<b>MAX SPECIFIC GRAVITY*</b>	1
<b>TEMPERATURE RANGE</b>	-4°F to +185°F (-20°C to +85°C)
<b>DIMENSIONS</b>	3.8" high x 6.6" long x 2.9" wide (96mm x 168mm x 74mm)
<b>WEIGHT</b>	1.5lb (0.7kg)

\*Assuming maximum viscosity of 30 cp. Refer to Xylem for higher viscosities and specific gravities.



### DIMENSIONAL DRAWINGS

Unless otherwise stated, dimensions are in inches and (mm).

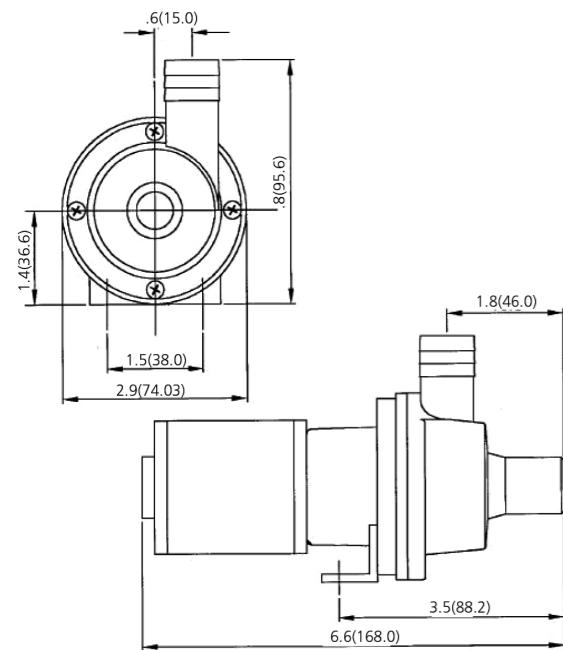

# Centrifugal Pumps 02

SUBMERSIBLE



## Introduction to Rule Submersible Pumps

Rule submersible pumps are unrivaled in their combination of versatility, performance, reliability and value. Their small size enables them to be installed in confined spaces where water needs to be circulated or removed. They are totally sealed so they can be left permanently submerged. The electrical safety of pumps fitted with low voltage DC motors is superior to mains voltage pumps.

- Compact, efficient, long-life motors
- Totally submersible
- Rust and corrosion proof
- Silent and vibration-free operation

## General Purpose Centrifugal Pumps



### FOR INTERNATIONAL & US MARKETS

The Rule general purpose pump is designed with a 1-1/2" (38mm) inlet and 1-1/2" (38mm) discharge outlet. The Rule general purpose pump must be mounted below the waterline. It does not deliver high pressure, nor is it self-priming. It delivers lots of water, but at low pressure. 12 volts DC unless noted.

### MODELS

MODEL #	CERTIFICATION	CAPACITY
17A	CE	3800 GPH (14380 LPH)
18A	CE	24V - 3700 GPH (14002 LPH)
19A	CE	32V - 3700 GPH (14002 LPH)

## 110 Volt Pumps



### FOR US MARKETS

Designed to remove water from basements, garages, stairwells, utility rooms, and other utility applications. Available in non-automatic and automatic versions utilizing standard 110 volt AC current. UL listed.

### MODELS

AUTOMATIC MODEL #	CERTIFICATION	CAPACITY	CORD	ADAPTERS INCLUDED
A53S	UL	1800 GPH (6814 LPH)	8' (2.4m)	Garden hose and rigid pipe #57
A53S-24	UL	1800 GPH (6814 LPH)	24' (7.3m)	Garden hose and rigid pipe #57
NON-AUTOMATIC MODEL #	CERTIFICATION	CAPACITY	CORD	ADAPTERS INCLUDED
A53D	UL	1800 GPH (6814 LPH)	8' (2.4m)	Garden hose and rigid pipe #57

# 02 Centrifugal Pumps



## Slimline Pumps

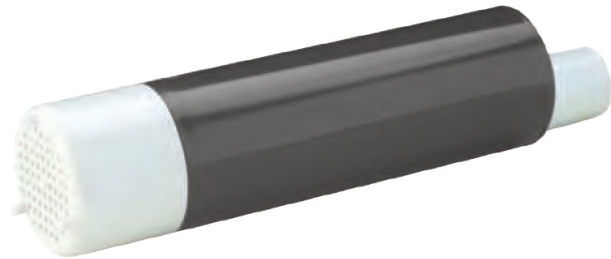

### FOR INTERNATIONAL & US MARKETS

There are four sizes in the Slimline series, which includes strainers for use in submersible mode or, when the filter is removed, for use in the inline pumping mode. These pumps are capable of pumping hot or cold fresh water, seawater, antifreeze and even diesel. These pumps can be used to pump water from tight spaces, for general wash down, water and diesel transfer, or engine winterizing.

Rule has developed a family of compact combination submersible and inline pumps and portable pump kits designed for a wide variety of uses.

### FEATURES

- Delivers up to 425 GPH (1608 LPH)
- Pumps fresh and seawater, diesel
- Continuous duty (not all models)

### APPLICATIONS

- Water testing
- Borehole testing
- Agricultural spraying
- General transfer
- Diesel refuelling and transfer
- Garden watering
- Container filling and emptying
- Sink draining
- Engine winterizing

### MODELS

MODEL #	CERTIFICATION	VOLTS	DESCRIPTION	CAPACITY
iL425P	CE	12V	iL425 Plus	425 GPH (1608 LPH)
iL425P-24	CE	24V	iL425 Plus	425 GPH (1608 LPH)
iL280P	CE	12V	iL280 Plus	280 GPH (1059 LPH)
iL280P-24	CE	24V	iL280 Plus	280 GPH (1059 LPH)
iL200P	CE	12V	iL200 Plus	200 GPH (756 LPH)
iL200P-24	CE	24V	iL200 Plus	200 GPH (756 LPH)
iL200*	CE	12V	iL200	200 GPH (756 LPH)

\*Not for use with diesel fuel.

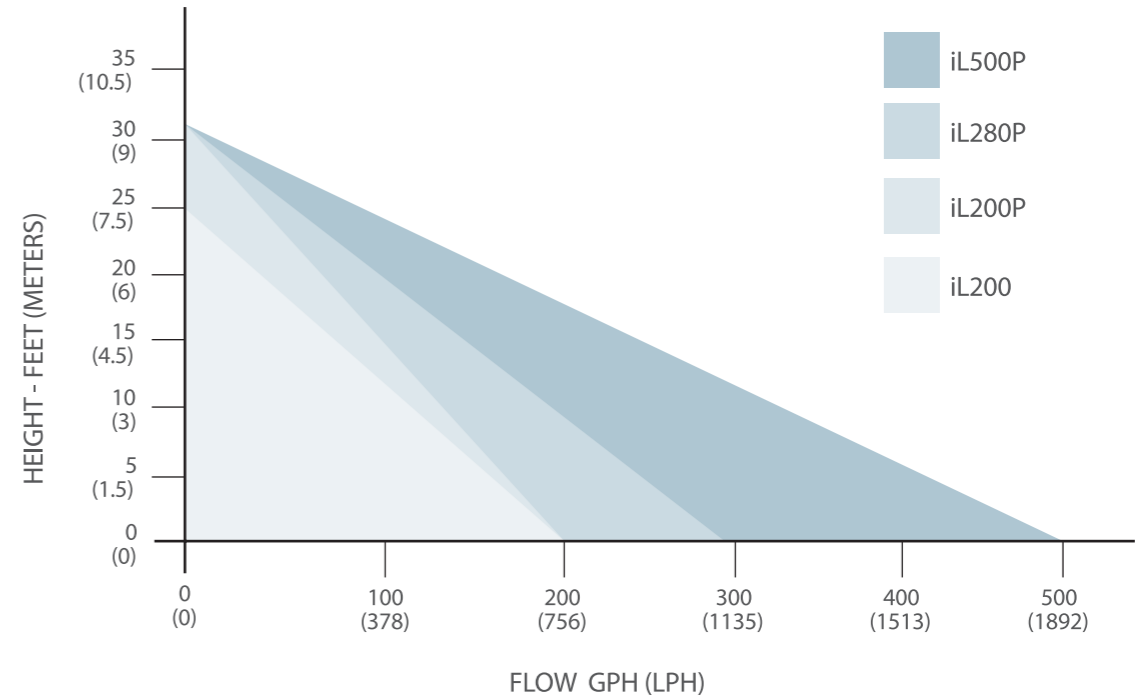

### SPECIFICATIONS

MODEL	IL425PLUS	IL280PLUS	IL200PLUS	IL200
<b>PUMP TYPE</b>	Centrifugal submersible and inline pump			
<b>CURRENT</b>	12V – 6 amp, 24V – 3 amp	12V – 4.5 amp, 24V – 2.5 amp	12V – 4.5 amp, 24V – 2.5 amp	12V – 2.8 amp
<b>HEAD</b>	32' (9.7m)	32' (9.7m)	32' (9.7m)	25' (7.6m)
<b>FLOW RATE</b>	425 GPH (1608 LPH)	280 GPH (1080 LPH)	200 GPH (760 LPH)	200 GPH (760 LPH)
<b>OUTLETS</b>	3/4" (19mm) ID hose	1/2" (13mm) ID hose	1/2" (13mm) ID hose	3/8" (10mm) and 1/2" (13mm) ID hose
<b>PRESSURE</b>	14 psi (0.96 bar)	14 psi (0.96 bar)	11 psi (0.76 bar)	14 psi (0.96 bar)
<b>BODY</b>	Acetal	Acetal	Acetal	Styrene
<b>LENGTH</b>	6.5" (165mm)	6.5" (165mm)	5.6" (142mm)	5.1" (130mm)
<b>DIAMETER</b>	1.5" (38mm)	1.5" (38mm)	1.5" (38mm)	1.4" (36mm)
<b>CABLE LENGTH</b>	13' (4m)	13' (4m)	13' (4m)	3' (1m)
<b>LIQUID</b>	Fresh and seawater / diesel	Fresh and seawater / diesel	Fresh and seawater / diesel	Fresh and seawater
<b>OPERATING TEMPERATURE</b>	Water systems to 176°F (80°C)	Water systems to 176°F (80°C)	Water systems to 176°F (80°C)	Water systems to 140°F (60°C)

## Slimline Pump Kit



### FOR INTERNATIONAL & US MARKETS

The portable pump kits come complete with lay-flat hose and battery terminal clips, and are ready to use!

### FEATURES

- Pump
- 10' (3m) wire with battery clamps
- Lay-flat hose
- Spray nozzle

### APPLICATIONS

- Water testing
- Borehole testing
- Agricultural spraying
- General transfer
- Diesel transfer
- Garden watering

### MODELS

MODEL #	CERTIFICATION	VOLTS	DESCRIPTION	CAPACITY
iL425PK	CE	12V	iL425 Plus Kit	425 GPH (1608 LPH)
iL425PK-24	CE	24V	iL425 Plus Kit	425 GPH (1608 LPH)
iL280PK	CE	12V	iL280 Plus Kit	280 GPH (1059 LPH)
iL280PK-24	CE	24V	iL280 Plus Kit	280 GPH (1059 LPH)
iL200K*	CE	12V	iL200 Plus Kit	200 GPH (756 LPH)

\*Not for use with diesel fuel.



# Diaphragm Pumps 03

Introduction

Motor Driven

Air Driven

Accessories & Fittings



**FLOJET**<sup>®</sup>

**JABSCO**<sup>®</sup>

# 03 Diaphragm Pumps

INTRODUCTION

## Diaphragm Pump Product Range

### FEATURES

Expect only the best. With over 30 years of pump design and manufacturing experience, Flojet is committed to delivering the hardest-working and longest-lasting pumps. No matter the application, Flojet can provide a superior pump to match all your requirements.

Operational "Box" for Flojet diaphragm pumps (Options below are not available to all ranges.)

<b>PRESSURE</b>	0-150 psi (0-10 bar)
<b>OPEN FLOW</b>	0.3-6 GPM (1.1-22.7 LPM)
<b>ELASTOMERS</b>	EP/PP blend, FKM, FFKM, buna, buna/PP blend, EPDM, silicone
<b>BODY MATERIALS</b>	Polypropylene, celcon, nylon
<b>SWITCH RANGE</b>	20-150 psi (1.4-10 bar) or no switch
<b>BYPASS RANGE</b>	15-150 psi (1-10.4 bar) or no bypass
<b>POWER</b>	Electric: 12-36V DC, 110V AC, 230V AC Gas: air, CO <sub>2</sub> , or Nitrogen

COMMON BRAND ID	
BRAND NAME	ELASTOMER MATERIAL
Geolast	Buna/PP blend
Kalrez	Perfleuroelastomer (FFKM)
Santoprene	EP/PP blend
Viton	FKM

The above defines the box for Flojet's standard products. As Flojet is also a motor manufacturer, we are capable of providing specific solutions to your pumping needs. If the above range is not suitable, please contact the factory to learn about our full range of Flojet diaphragm pumps.

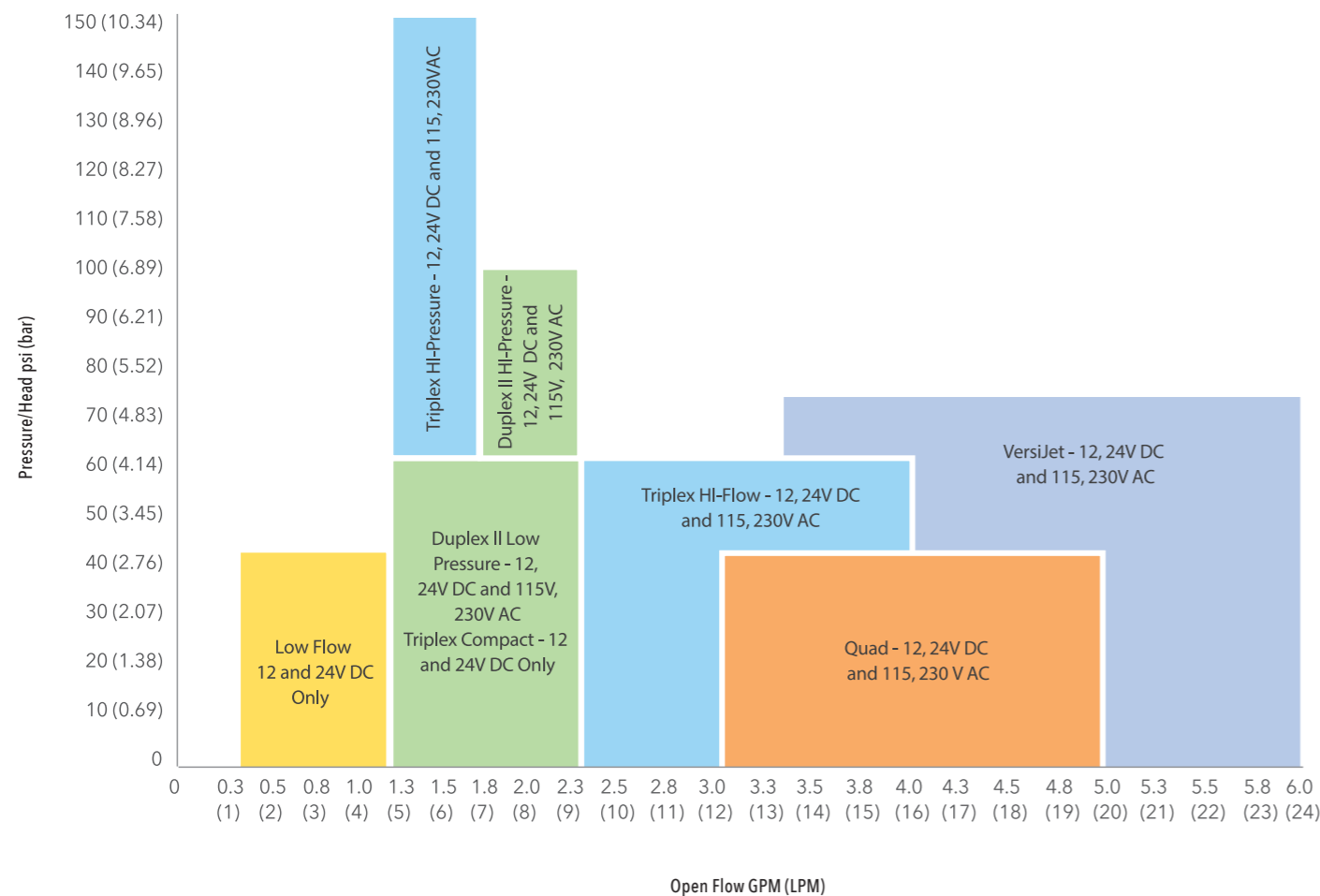

**GAS WARNING**  
No pump manufactured by Xylem should be used for gasoline or any fluid with a flash point below 100°F (38°C).

### SELF-PRIMING – WET AND DRY

- Dry vertical lift from 2.5 (0.8m) up to an outstanding 27.9' (8.5m)

### CAN RUN DRY WITHOUT DAMAGE

- Flojet diaphragm pumps can run dry for extended periods with no damage
- Compatible with a wide range of chemicals
- Sealless design (no shaft seal, so less leak issues)

### COMPACT SIZE AND LOW WEIGHT

- Highest flow rates for their size
- Plug-in ports for easy installation and servicing
- Flojet pumps can be mounted easily anywhere with functional mounting platforms and simple connections – fit it anywhere and plumb up

### SERVICE KITS AVAILABLE

- Modular design
- Low-cost, low-maintenance design means a trouble-free service life
- Spare parts and accessories are readily available and easy to install

### THE PRINCIPLE BEHIND POSITIVE DISPLACEMENT DIAPHRAGM PUMPS

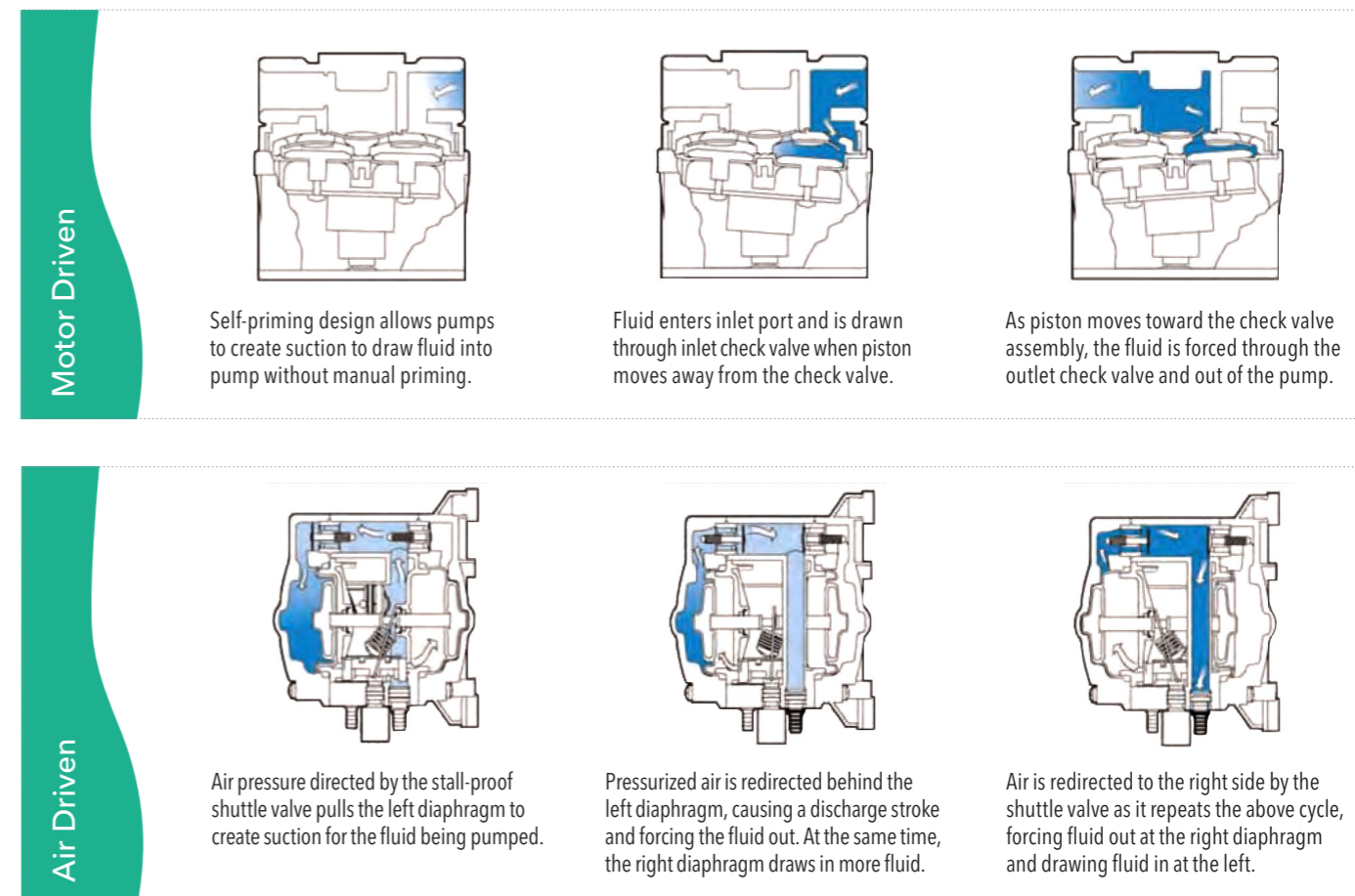

# 03 Diaphragm Pumps

MOTOR DRIVEN



## LF Plus Series



### FOR INTERNATIONAL & US MARKETS

These pumps are the ideal solution for many applications including spraying, fluid transfer, filtration, cooling, dispensing and pressure boosting.

### FEATURES

- Sealed pressure switch automatically starts and stops pump when discharge valve opens and closes
- Self-priming so pump can be located above supply tank
- Can run dry for extended periods of time without damage
- Built-in thermal protector
- Low amp draw for battery-powered applications
- Optional sealed motor with protective metal cooling finned cover

### PERFORMANCE

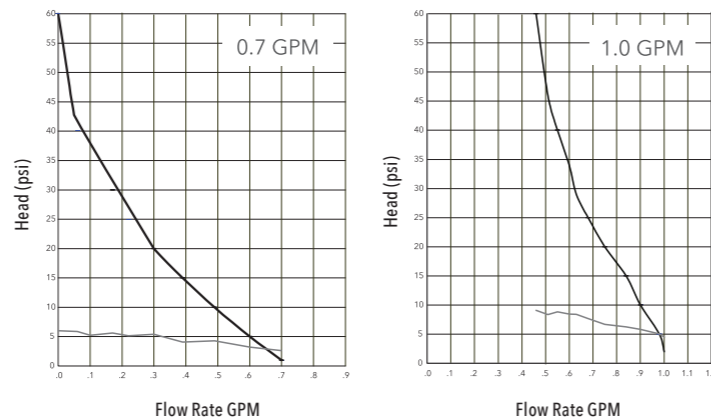

### DIMENSIONAL DRAWINGS

Unless otherwise stated, dimensions are in inches and (mm).

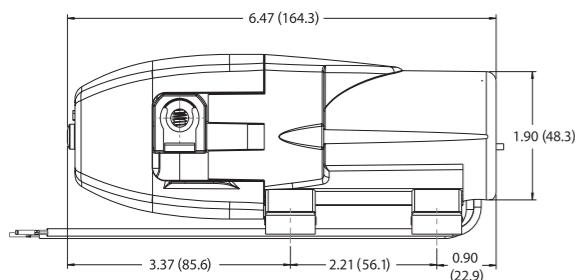
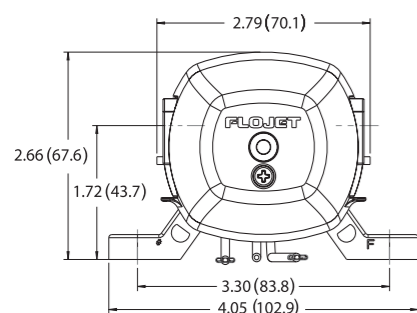

### SPECIFICATIONS

<b>PUMP DESIGN</b>	Reciprocating diaphragm
<b>VOLTAGE**</b>	12V DC, 24V DC, 115V AC
<b>MAX FLOW RATE</b>	0.6 GPM (2.3 LPM)–1 GPM (3.8 LPM)
<b>DUTY CYCLE</b>	Intermittent
<b>MAX PRESSURE</b>	40 psi (2.8 bar) when no pressure switch is present
<b>PRESSURE SWITCH SETTING**</b>	40 psi (2.8 bar) off, 25 psi (1.7 bar) on
<b>SELF-PRIMING</b>	Vertical height 30" (76cm)
<b>PORTS*</b>	Quick connect barb 1/4" (6mm) and 3/8" (10mm); John Guest/quick fit 1/4" (6mm) and 3/8" (10mm) straight and elbow available
<b>HOUSING</b>	Polypropylene
<b>CHECK VALVE SPRING</b>	Stainless steel
<b>LIQUID TEMPERATURE RANGE</b>	36°F (2°C) to 110°F (43°C)

IOM #81000-230

\* See accessories section  
 \*\* See table

### MODELS

MODEL #	CE	VOLTAGE	OPEN FLOW	SWITCH	BYPASS	MAX AMP DRAW	DIAPHRAGM	CHECK VALVE	PORTS
LFP521002	No	115V AC	0.7 GPM (2.6 LPM)	No	No	0.3A	EP/PP blend	EPDM	Quick disconnect 3/8" (10mm) HB straight
LFP521402	No	115V AC	0.7 GPM (2.6 LPM)	40 psi (2.8 bar)	No	0.3A	EP/PP blend	EPDM	Quick disconnect 3/8" (10mm) HB straight
LFP521401	No	115V AC	0.7 GPM (2.6 LPM)	40 psi (2.8 bar)	No	0.3A	EP/PP blend	FKM	Quick disconnect 3/8" (10mm) HB straight
LFP521401	No	12V DC	0.7 GPM (2.6 LPM)	40 psi (2.8 bar)	55 psi (3.8 bar)	2A	EP/PP blend	FKM	Quick disconnect 3/8" (10mm) HB straight
LFP122201	RLFP122201	12V DC	1 GPM (3.8 LPM)	35 psi (2.4 bar)	No	3.5A	EP/PP blend	FKM	Quick disconnect 3/8" (10mm) HB straight
LFP122005	No	12V DC	1 GPM (3.8 LPM)	No	No	3.5A	Buna/PP blend	FKM	Quick disconnect 3/8" (10mm) HB straight
LFP122202	RLFP122202	12V DC	1 GPM (3.8 LPM)	35 psi (2.4 bar)	No	3.5A	EP/PP blend	EPDM	Quick disconnect 3/8" (10mm) HB straight
LFP122201	RLFP122201	12V DC	1 GPM (3.8 LPM)	35 psi (2.4 bar)	No	3.5A	EP/PP blend	FKM	Quick disconnect 3/8" (10mm) HB straight
LFP121421	RLFP121421	12V DC	0.7 GPM (2.6 LPM)	40 psi (2.8 bar)	55 psi (3.8 bar)	2A	EP/PP blend	FKM	Quick disconnect 3/8" (10mm) HB straight
LFP222002	RLFP222002	24V DC	1 GPM (3.8 LPM)	No	No	2A	EP/PP blend	EPDM	Quick disconnect 3/8" (10mm) HB straight
N/A	RLFP222202	24V DC	1 GPM (3.8 LPM)	35 psi (2.4 bar)	No	2A	EP/PP blend	EPDM	Quick disconnect 3/8" (10mm) HB straight
N/A	RFLP222201	24V DC	1 GPM (3.8 LPM)	35 psi (2.4 bar)	No	2A	EP/PP blend	FKM	Quick disconnect 3/8" (10mm) HB straight
N/A	RFLP221422	24V DC	0.7 GPM (2.6 LPM)	40 psi (2.8 bar)	55 psi (3.8 bar)	2A	EP/PP blend	EPDM	Quick disconnect 3/8" (10mm) HB straight

Additional pump models are available. Alternate barb sizes and tubing connection configurations are available. Please contact us if you do not see what you are looking for.

# 03 Diaphragm Pumps

MOTOR DRIVEN



## Duplex II Series



The Duplex II series of pumps incorporates the best technology and features developed by Flojet. Everything from the back-flow preventer, check valves, bearings and diaphragm assembly to the motor, has been designed to make this the most reliable diaphragm pump available. Higher efficiency of the pump is evident in the longer life of the motor pump unit. The diaphragm design combined with the new valves makes the pump capable of pulling higher dry vacuum. Duplex II is available in various performance ranges and voltages, and with a choice of elastomers, making it easily adaptable to a diverse range of applications.

### FEATURES

- Self-priming up to 8' (2.4m)
- Can run dry without damage
- Chemically resistant materials
- Internal bypass standard
- Built-in back-flow preventer
- Heavy duty ball bearing drive system
- UL, CSA and CE models available

### SPECIFICATIONS

<b>PUMP DESIGN</b>	Positive displacement two-piston design
<b>VOLTAGE</b>	12V DC, 24V DC, 115V AC, 230V AC
<b>MAX FLOW RATE</b>	High Pressure - 2.2 GPM (8.3 LPM) Medium and Low Pressure - 1.6 GPM (6.1 LPM)
<b>CYCLE</b>	50/60Hz for AC models
<b>MAX PRESURE</b>	100 psi (6.9 bar)
<b>PRESSURE SWITCH SETTING</b>	15 psi (1.3 bar), 30 psi (2.1 bar), 45 psi (3.1 bar), 60 psi (4.1 bar), 80 psi (5.5 bar) and 100 psi (6.8 bar)
<b>SELF-PRIMING</b>	Up to 8' (2.4m)
<b>PORTS</b>	3/8" (10mm) NPT female
<b>MOTOR</b>	Permanent magnet with solid state rectifier
<b>WETTED PARTS</b>	Polypropylene, FKM, buna or EPDM
<b>WEIGHT</b>	4-5lb (1.8-2.3kg)

### DIMENSIONAL DRAWINGS

Unless otherwise stated, dimensions are in inches and (mm).

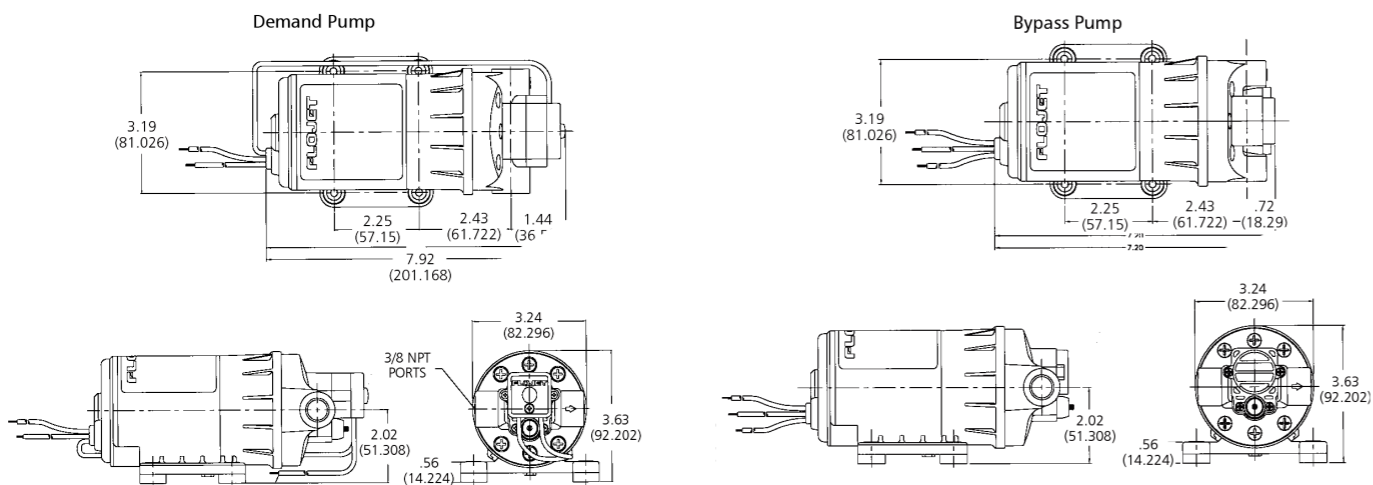

### PERFORMANCE

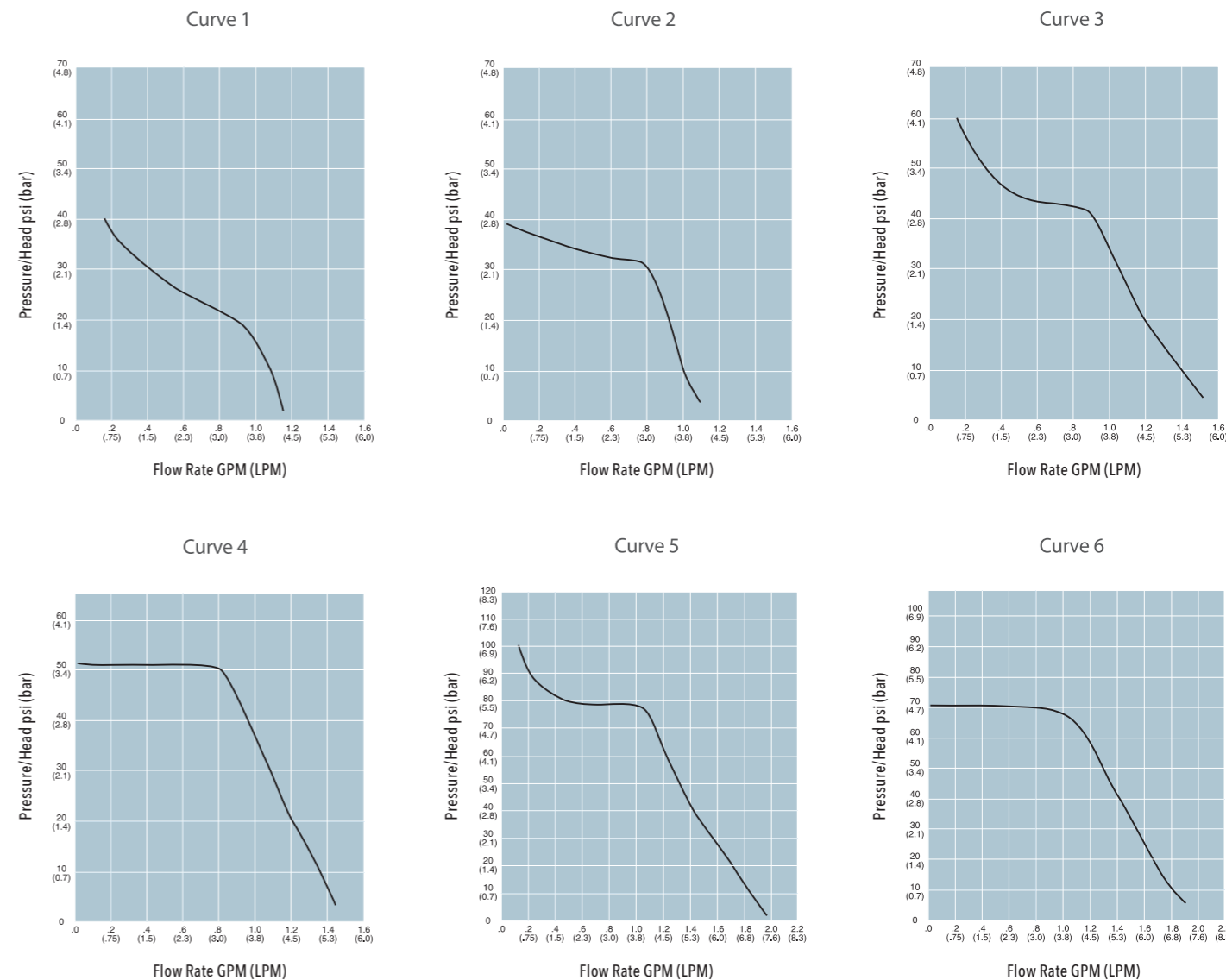

See following pages for model specification charts.

# 03 Diaphragm Pumps

MOTOR DRIVEN

**FLOJET®**

## Duplex II Series

MODEL #	CE	VOLTAGE	OPEN FLOW	SWITCH	BYPASS	MAX AMP DRAW	DIAPHRAGM	CHECK VALVE	CURVE #	NOTES
D3631B1311	N/A	115V AC	1.6 GPM (6.1 LPM)	No	50 psi (3.4 bar)	0.6A	Buna	Buna	4	
D3631B5011	N/A	115V AC	1.6 GPM (6.1 LPM)	60 psi (4.1 bar)	40 psi (2.8 bar)	0.6A	Buna	Buna	3	
D3631V1311	N/A	115V AC	1.6 GPM (6.1 LPM)	No	50 psi (3.4 bar)	0.6A	FKM	FKM	4	
D3631V5011	N/A	115V AC	1.6 GPM (6.1 LPM)	60 psi (4.1 bar)	40 psi (2.8 bar)	0.6A	FKM	FKM	3	
D3635B7011	N/A	115V AC	2 GPM (7.6 LPM)	100 psi (6.9 bar)	80 psi (5.5 bar)	0.8A	Buna	Buna	5	
D3835B5011	N/A	115V AC	2 GPM (7.6 LPM)	60 psi (4.1 bar)	40 psi (2.8 bar)	0.6A	Buna	Buna	3	6' cord
D3835H5011	N/A	115V AC	2 GPM (7.6 LPM)	60 psi (4.1 bar)	40 psi (2.8 bar)	0.6A	EP/PP blend	EPDM	3	6' cord
D3835V5011	N/A	115V AC	2 GPM (7.6 LPM)	60 psi (4.1 bar)	40 psi (2.8 bar)	0.6A	FKM	FKM	3	6' cord
D21X003	N/A	12V DC	1.6 GPM (6.1 LPM)	No	No	9A	EP/PP blend	FKM	6	Inline fuse and rocker switch
D21X005	N/A	12V DC	2 GPM (7.6 LPM)	60 psi (4.1 bar)	40 psi (2.8 bar)	7A	EP/PP blend	FKM	3	Inline fuse and rocker switch
D3131B1311	D3131B1311R	12V DC	1.6 GPM (6.1 LPM)	No	50 psi (3.4 bar)	7A	Buna	Buna	4	
D3131B5011	D3131B5011R	12V DC	1.6 GPM (6.1 LPM)	60 psi (4.1 bar)	40 psi (2.8 bar)	7A	Buna	Buna	3	
D3131H1311	D3131H1311R	12V DC	1.6 GPM (6.1 LPM)	No	50 psi (3.4 bar)	7A	EP/PP blend	EPDM	4	
D3131H5011	D3131H5011R	12V DC	1.6 GPM (6.1 LPM)	60 psi (4.1 bar)	40 psi (2.8 bar)	7A	EP/PP blend	EPDM	3	
D3131V1311	D3131V1311R	12V DC	1.6 GPM (6.1 LPM)	No	50 psi (3.4 bar)	7A	FKM	FKM	4	
D3131V5011	D3131V5011R	12V DC	1.6 GPM (6.1 LPM)	60 psi (4.1 bar)	40 psi (2.8 bar)	7A	FKM	FKM	3	
D3135B7011	D3135B7011R	12V DC	2 GPM (7.6 LPM)	100 psi (6.9 bar)	80 psi (5.5 bar)	9A	Buna	Buna	5	
D3135H7011	D3135H7011R	12V DC	2 GPM (7.6 LPM)	100 psi (6.9 bar)	80 psi (5.5 bar)	9A	EP/PP blend	EPDM	5	
D3121V1211	D3121V1211R	12V DC	1.1 GPM (4.3 LPM)	No	30 psi (2.1 bar)	3A	FKM	FKM	1	
D3121V3011	D3121V3011R	12V DC	1.1 GPM (4.3 LPM)	30 psi (2.1 bar)	No	3A	FKM	FKM	2	
D3135B1411	D3135B1411R	12V DC	2 GPM (7.6 LPM)	No	70 psi (4.8 bar)	7A	Buna	Buna	6	
D71X000	N/A	12V DC	2 GPM (7.6 LPM)	No	50 psi (3.4 bar)	8A	Buna	Buna	6	Heavy duty motor
D71X001	N/A	12V DC	2 GPM (7.6 LPM)	No	50 psi (3.4 bar)	8A	Buna	Buna	6	Heavy duty motor and discharge left
D2131F5011	N/A	12V DC	1.6 GPM (6.1 LPM)	60 psi (4.1 bar)	40 psi (2.8 bar)	0.6A	EP/PP blend	FKM	3	
D2131F5011	N/A	12V DC	1.6 GPM (6.1 LPM)	60 psi (4.1 bar)	40 psi (2.8 bar)	0.6A	EP/PP blend	FKM	3	Heavy duty motor
D27X007	N/A	12V DC	1.6 GPM (6.1 LPM)	No	50 psi (3.4 bar)	10A	Buna	FKM	4	Inline fuse and rocker switch
D3732B1311	D3732B1311RL	230V AC	1.6 GPM (6.1 LPM)	No	50 psi (3.4 bar)	0.4A	Buna	Buna	4	
D3732B5011	D3732B5011RL	230V AC	1.6 GPM (6.1 LPM)	60 psi (4.1 bar)	40 psi (2.8 bar)	0.6A	Buna	Buna	3	
D3732H1311	D3732H1311RL	230V AC	1.6 GPM (6.1 LPM)	No	50 psi (3.4 bar)	0.4A	EP/PP blend	EPDM	4	

MODEL #	CE	VOLTAGE	OPEN FLOW	SWITCH	BYPASS	MAX AMP DRAW	DIAPHRAGM	CHECK VALVE	CURVE #	NOTES
D3732H5011	D3732H5011RL	230V AC	1.6 GPM (6.1 LPM)	60 psi (4.1 bar)	40 psi (2.8 bar)	0.6A	EP/PP blend	EPDM	3	
D3732V1311	D3732V1311RL	230V AC	1.6 GPM (6.1 LPM)	No	50 psi (3.4 bar)	0.4A	FKM	FKM	4	
D3732V5011	D3732V5011RL	230V AC	1.6 GPM (6.1 LPM)	60 psi (4.1 bar)	40 psi (2.8 bar)	0.6A	FKM	FKM	3	
D3735B7011	D3735B7011RL	230V AC	2 GPM (7.6 LPM)	100 psi (6.9 bar)	80 psi (5.5 bar)	0.5A	Buna	Buna	5	
D3735H7011	D3735H7011RL	230V AC	2 GPM (7.6 LPM)	100 psi (6.9 bar)	80 psi (5.5 bar)	0.5A	EP/PP blend	EPDM	5	
D3231B1311	D3231B1311R	24V DC	1.6 GPM (6.1 LPM)	No	50 psi (3.4 bar)	3.5A	Buna	Buna	4	
D3231B5011	D3231B5011R	24V DC	1.6 GPM (6.1 LPM)	60 psi (4.1 bar)	40 psi (2.8 bar)	3.5A	Buna	Buna	3	
D3231H1311	D3231H1311R	24V DC	1.6 GPM (6.1 LPM)	No	50 psi (3.4 bar)	3.5A	EP/PP blend	EPDM	4	
D3231H5011	D3231H5011R	24V DC	1.6 GPM (6.1 LPM)	60 psi (4.1 bar)	40 psi (2.8 bar)	3.5A	EP/PP blend	EPDM	3	
D3231V1311	D3231V1311R	24V DC	1.6 GPM (6.1 LPM)	No	50 psi (3.4 bar)	3.5A	FKM	FKM	4	
D3231V5011	D3231V5011R	24V DC	1.6 GPM (6.1 LPM)	60 psi (4.1 bar)	40 psi (2.8 bar)	3.5A	FKM	FKM	3	
D3235B7011	D3235B7011R	24V DC	2 GPM (7.6 LPM)	100 psi (6.9 bar)	80 psi (5.5 bar)	4.5A	Buna	Buna	5	
D3235H7011	D3235H7011R	24V DC	2 GPM (7.6 LPM)	100 psi (6.9 bar)	80 psi (5.5 bar)	4.5A	EP/PP blend	EPDM	5	
D3221V1211	D3221V1211R	24V DC	1.1 GPM (4.3 LPM)	No	30 psi (2.1 bar)	1.5A	FKM	FKM	1	
D3221V3011	D3221V3011R	24V DC	1.1 GPM (4.3 LPM)	30 psi (2.1 bar)	No	1.5A	FKM	FKM	2	
D1335E7011	N/A	36V DC	2 GPM (7.6 LPM)	100 psi (6.9 bar)	80 psi (5.5 bar)	0.5A	EPDM	EPDM	5	

# 03 Diaphragm Pumps

MOTOR DRIVEN

## Triplex Compact Series



The Triplex Compact range pump was designed specifically for the agricultural market. Flojet's three chamber design, including versatile features, makes it ideal for sprayers, transfer and dispensing applications. This automatic demand pump is fitted with a sealed pressure switch and motor. It has the ideal footprint for installation in areas with space restrictions.

### FEATURES

- Compact automatic demand pump
- Sealed pressure switch and motor
- Self-priming; pump can be located above supply tank
- Can run dry for extended periods of time without damage
- Flow rates to 2 GPM (7.6 LPM) and operating pressure to 60 psi (4.1 bar)

### APPLICATIONS

- Small boom and spot spraying
- Foam marking
- Silage treatment
- Estate spraying
- Livestock and poultry cooling
- Dispensing
- Transfer of liquids

### PERFORMANCE

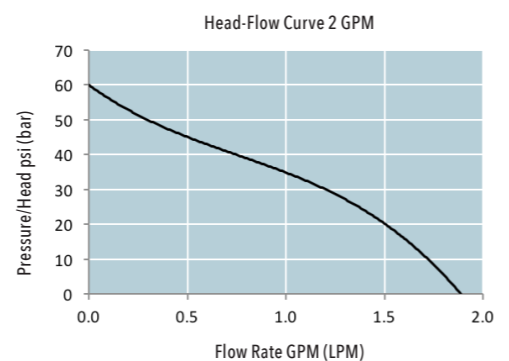
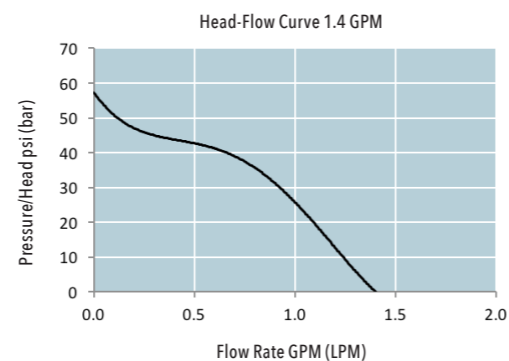

### SPECIFICATIONS

<b>PUMP DESIGN</b>	Motor-operated, 3-chamber diaphragm
<b>VOLTAGE</b>	12V DC, 24V DC
<b>MAX FLOW RATE</b>	2 GPM (7.6 LPM)
<b>DUTY CYCLE</b>	Intermittent
<b>MAX PRESSURE</b>	60 psi (4.1 bar)
<b>PORTS</b>	3/8" (10mm) NPTF
<b>LIQUID TEMPERATURE RANGE</b>	40°F (4°C) to 140°F (60°C)
<b>CERTIFICATIONS</b>	CE, NSF components
<b>WEIGHT</b>	3.4lb (1.5kg)



### DIMENSIONAL DRAWINGS

Unless otherwise stated, dimensions are in inches and (mm).

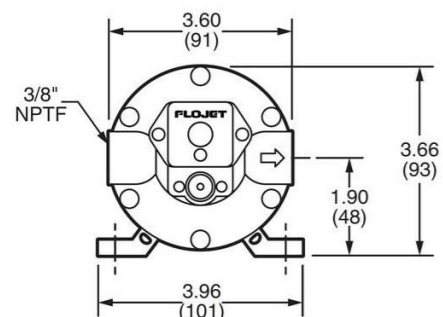
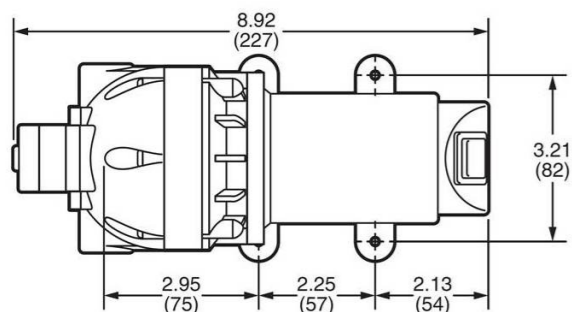

### MODELS

MODEL #	CE	VOLTAGE	OPEN FLOW	SWITCH	BYPASS	MAX AMP DRAW	DIAPHRAGM	CHECK VALVE	CURVE #
03501132	R3501132	12V	1.4 GPM (5.3 LPM)	60 psi (4.1 bar)	Yes	6A	EP/PP blend	FKM	1
03501136	R3501136	12V	2 GPM (7.6 LPM)	60 psi (4.1 bar)	Yes	8A	EP/PP blend	FKM	2
03501142	R3501142	12V	1.4 GPM (5.3 LPM)	60 psi (4.1 bar)	Yes	6A	EP/PP blend	EPDM	1
03501146	R3501146	12V	2 GPM (7.6 LPM)	60 psi (4.1 bar)	Yes	8A	EP/PP blend	EPDM	2
03B01132	R3B01132	12V	1.4 GPM (5.3 LPM)	No	50 psi (3.4 bar)	6A	EP/PP blend	FKM	1
03B01136	R3B01136	12V	2 GPM (7.6 LPM)	No	50 psi (3.4 bar)	8A	EP/PP blend	FKM	2
03B01142	R3B01142	12V	1.4 GPM (5.3 LPM)	No	50 psi (3.4 bar)	6A	EP/PP blend	EPDM	1
03B01146	R3B01146	12V	2 GPM (7.6 LPM)	No	50 psi (3.4 bar)	8A	EP/PP blend	EPDM	2
03501332	R3501332	24V	1.4 GPM (5.3 LPM)	60 psi (4.1 bar)	Yes	3A	EP/PP blend	FKM	1
03501336	R3501336	24V	2 GPM (7.6 LPM)	60 psi (4.1 bar)	Yes	4A	EP/PP blend	FKM	2
03501342	R3501342	24V	1.4 GPM (5.3 LPM)	60 psi (4.1 bar)	Yes	3A	EP/PP blend	EPDM	1
03501346	R3501346	24V	2 GPM (7.6 LPM)	60 psi (4.1 bar)	Yes	4A	EP/PP blend	EPDM	2
03B01332	R3B01332	24V	1.4 GPM (5.3 LPM)	No	50 psi (3.4 bar)	3A	EP/PP blend	FKM	1
03B01336	R3B01336	24V	2 GPM (7.6 LPM)	No	50 psi (3.4 bar)	4A	EP/PP blend	FKM	2
03B01342	R3B01342	24V	1.4 GPM (5.3 LPM)	No	50 psi (3.4 bar)	3A	EP/PP blend	EPDM	1
03B01346	R3B01346	24V	2 GPM (7.6 LPM)	No	50 psi (3.4 bar)	4A	EP/PP blend	EPDM	2

# 03 Diaphragm Pumps

MOTOR DRIVEN

FLOJET®

## Triplex Hi-Pressure Series



Flojet Triplex Hi-Pressure diaphragm pumps are capable of pressures up to 150 psi (10.3 bar), some of the highest pressures available in the diaphragm pump industry. This is ideal for applications such as spraying, misting, filtration, cooling, dispensing and pressure boosting.

### FEATURES

- Constructed from a selection of materials suitable for handling a broad range of chemicals
- Sealed pressure switch and motor
- Self-priming up to 8' (2.4m); pump can be located above supply tank
- Can run dry for extended periods of time without damage
- Flow rates to 1.4 GPM (5.5 LPM) and operating pressure to 150 psi (11 bar)

### APPLICATIONS

- Designed for wide range of applications
- Small boom and spot spraying
- Silage treatment
- Estate spraying
- Livestock and poultry cooling
- Dispensing
- Transfer of liquids

### SPECIFICATIONS

<b>PUMP DESIGN</b>	Motor-operated, 3-chamber diaphragm
<b>VOLTAGE</b>	12V DC, 24V DC, 115V AC, 230V AC
<b>MAX FLOW RATE</b>	1.4 GPM (5.5 LPM)
<b>DUTY CYCLE</b>	Intermittent
<b>CYCLES</b>	50/60Hz
<b>MAX PRESSURE</b>	Switch cutoff – 150 psi (101 bar) Max running pressure – 140 psi (9.7 bar)
<b>PORTS</b>	3/8" (10mm) NPTF
<b>MOTOR</b>	Permanent magnet DC and rectified (PMDC) AC
<b>PUMP HEAD</b>	Glass-filled nylon
<b>ELASTOMERS DIAPHRAGM</b>	EP/PP blend
<b>CHECK VALVE*</b>	EPDM or FKM
<b>LIQUID TEMPERATURE RANGE</b>	40°F (4°C) to 140°F (60°C)
<b>CERTIFICATIONS</b>	CE, NSF components
<b>WEIGHT</b>	7.6lb (3.5kg)

### DIMENSIONAL DRAWINGS

Unless otherwise stated, dimensions are in inches and (mm).

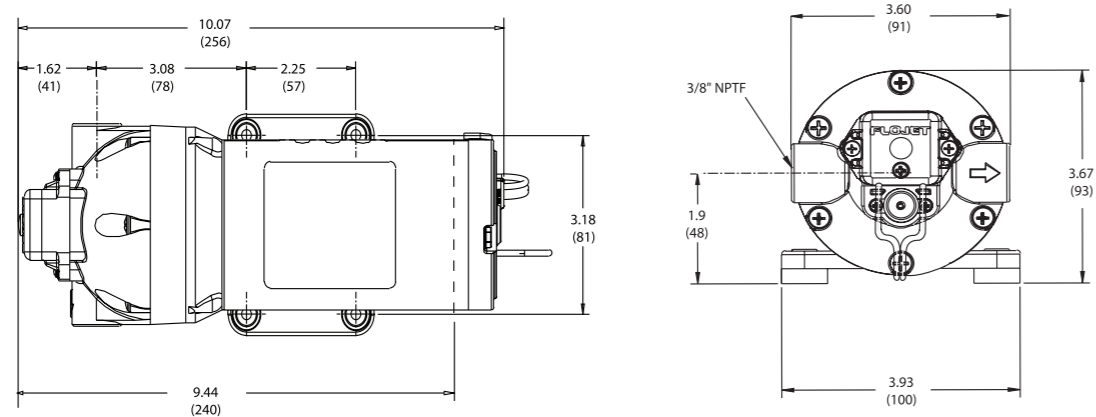

### PERFORMANCE

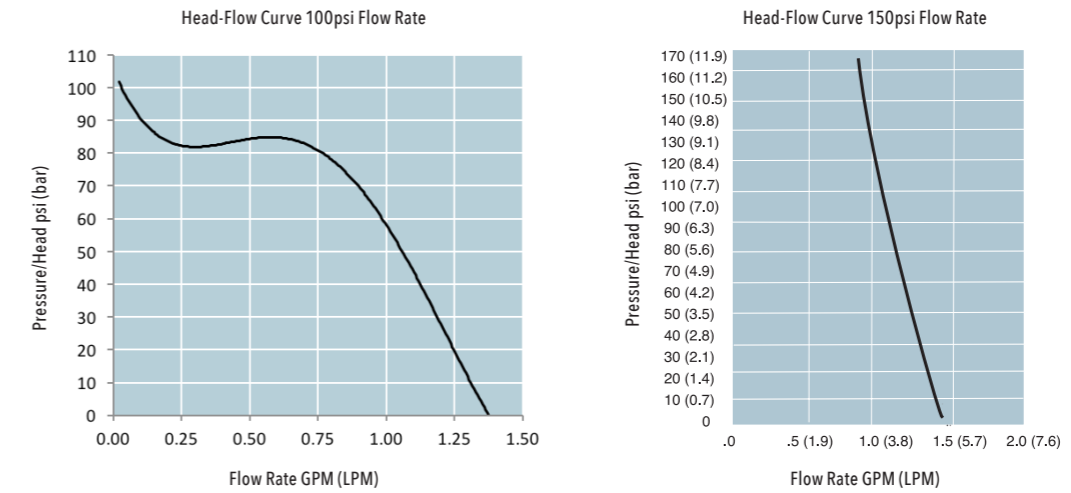

### MODELS

MODEL #	CE	VOLTAGE	OPEN FLOW	SWITCH	BYPASS	MAX AMP DRAW	DIAPHRAGM	CHECK VALVE
03711133	R3711133	12V	1.4 GPM (5.3 LPM)	100 psi (6.9 bar)	Yes	9A	EP/PP blend	FKM
03711143	R3711143	12V	1.4 GPM (5.3 LPM)	100 psi (6.9 bar)	Yes	9A	EP/PP blend	EPDM
03811133	R3811133	12V	1.4 GPM (5.3 LPM)	150 psi (10.3 bar)	No	10A	EP/PP blend	FKM
03811143	R3811143	12V	1.4 GPM (5.3 LPM)	150 psi (10.3 bar)	No	10A	EP/PP blend	EPDM
03711333	R3711333	24V	1.4 GPM (5.3 LPM)	100 psi (6.9 bar)	Yes	4A	EP/PP blend	FKM
03711343	R3711343	24V	1.4 GPM (5.3 LPM)	100 psi (6.9 bar)	Yes	4A	EP/PP blend	EPDM
03811333	R3811333	24V	1.4 GPM (5.3 LPM)	150 psi (10.3 bar)	No	5A	EP/PP blend	FKM
03811343	R3811343	24V	1.4 GPM (5.3 LPM)	150 psi (10.3 bar)	No	5A	EP/PP blend	EPDM
03711033	N/A	115V	1.4 GPM (5.3 LPM)	100 psi (6.9 bar)	Yes	1A	EP/PP blend	FKM
03711043	N/A	115V	1.4 GPM (5.3 LPM)	100 psi (6.9 bar)	Yes	1A	EP/PP blend	EPDM
03811033	N/A	115V	1.4 GPM (5.3 LPM)	150 psi (10.3 bar)	No	1A	EP/PP blend	FKM
03811043	N/A	115V	1.4 GPM (5.3 LPM)	150 psi (10.3 bar)	No	1A	EP/PP blend	EPDM
03711233	R3711233	230V	1.4 GPM (5.3 LPM)	100 psi (6.9 bar)	Yes	0.6A	EP/PP blend	FKM
03711243	R3711243	230V	1.4 GPM (5.3 LPM)	100 psi (6.9 bar)	Yes	0.6A	EP/PP blend	EPDM
03811233	R3811233	230V	1.4 GPM (5.3 LPM)	150 psi (10.3 bar)	No	0.6A	EP/PP blend	FKM
03811243	R3811243	230V	1.4 GPM (5.3 LPM)	150 psi (10.3 bar)	No	0.6A	EP/PP blend	EPDM

# 03 Diaphragm Pumps

MOTOR DRIVEN

FLOJET®

## Triplex Hi-Flow Series



Flojet Triplex Hi-Flow series pumps are designed for a wide range of applications and are constructed from a selection of materials suitable for handling a broad range of chemicals. The Triplex Hi-Flow pumps are self-priming and can run dry without harm.

### PERFORMANCE

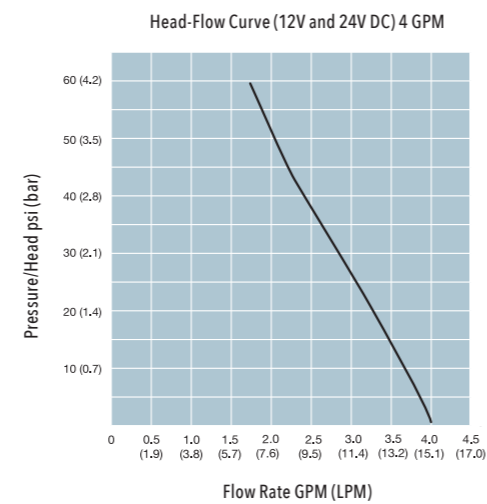
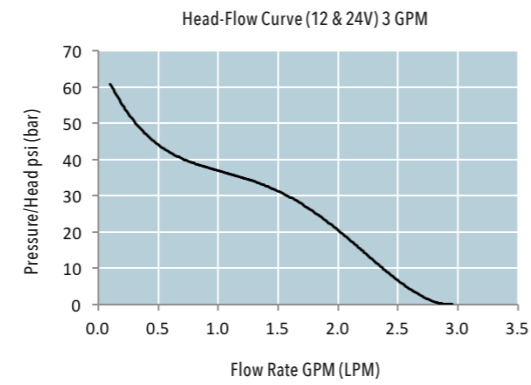

### SPECIFICATIONS

<b>PUMP DESIGN</b>	3-chamber diaphragm
<b>VOLTAGE</b>	12V DC, 24V DC
<b>MAX FLOW RATE</b>	4 GPM (15.1 LPM)
<b>MAX PRESSURE</b>	Switch cutoff – 60 psi (4.1 bar) Max running pressure – 50 psi (3.4 bar)
<b>PUMP HEAD</b>	Polypropylene
<b>DIAPHRAGM</b>	EP/PP blend
<b>IP RATING</b>	IP54
<b>WEIGHT</b>	5.1lb (2.3kg)



### MODELS

MODEL #	CE	VOLTAGE	OPEN FLOW	MAX AMP DRAW	SWITCH	BYPASS	CHECK VALVE
03521134	R3521134	12V	3 GPM (11.4 LPM)	5.2A	50 psi (3.4 bar)	Yes	FKM
03521139	R3521139	12V	4 GPM (15.1 LPM)	12A	60 psi (4.1 bar)	Yes	FKM
03521144	R3521144	12V	3 GPM (11.4 LPM)	5.2A	50 psi (3.4 bar)	Yes	EPDM
03521149	R3521149	12V	4 GPM (15.1 LPM)	12A	60 psi (4.1 bar)	Yes	EPDM
03521334	R3521334	24V	3 GPM (11.4 LPM)	2.5A	50 psi (3.4 bar)	Yes	FKM
03521339	R3521339	24V	4 GPM (15.1 LPM)	7A	60 psi (4.1 bar)	Yes	FKM
03521344	R3521344	24V	3 GPM (11.4 LPM)	2.5A	50 psi (3.4 bar)	Yes	EPDM
03521349	R3521349	24V	4 GPM (15.1 LPM)	7A	60 psi (4.1 bar)	Yes	EPDM

### HEAVY DUTY MODELS

MODEL #	CE	VOLTAGE	OPEN FLOW	MAX AMP DRAW	SWITCH	BYPASS	CHECK VALVE
N/A	R3B21500	12V	3.5 GPM (13.2 LPM)	8.5A	No	50 psi (3.4 bar)	FKM
N/A	R3B21501	24V	3.5 GPM (13.2 LPM)	5A	No	50 psi (3.4 bar)	FKM
N/A	R3B21502	12V	2.1 GPM (7.9 LPM)	4A	No	50 psi (3.4 bar)	FKM
N/A	R3B21503	24V	2.1 GPM (7.9 LPM)	4A	No	50 psi (3.4 bar)	FKM

### 3 GPM DIMENSIONAL DRAWINGS

Unless otherwise stated, dimensions are in inches and (mm).

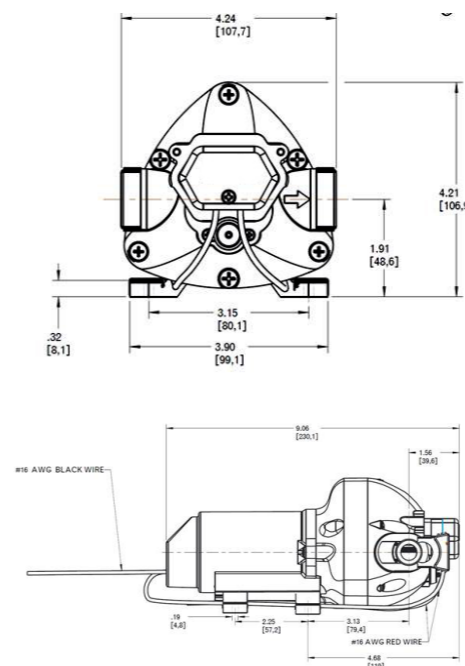

### 4 GPM DIMENSIONAL DRAWINGS

Unless otherwise stated, dimensions are in inches and (mm).

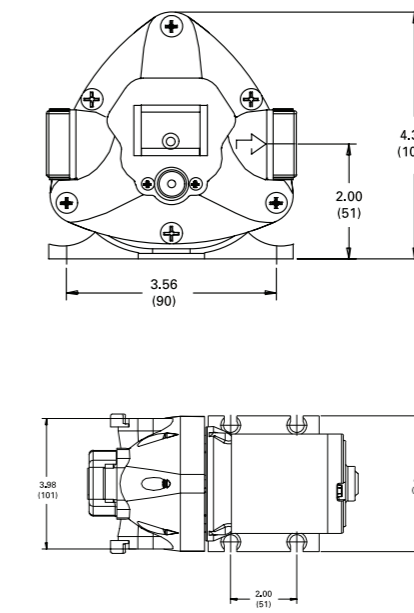

### R3B21 (HEAVY DUTY) ROAD ROLLER PUMP DIMENSIONAL DRAWINGS

Unless otherwise stated, dimensions are in inches and (mm).

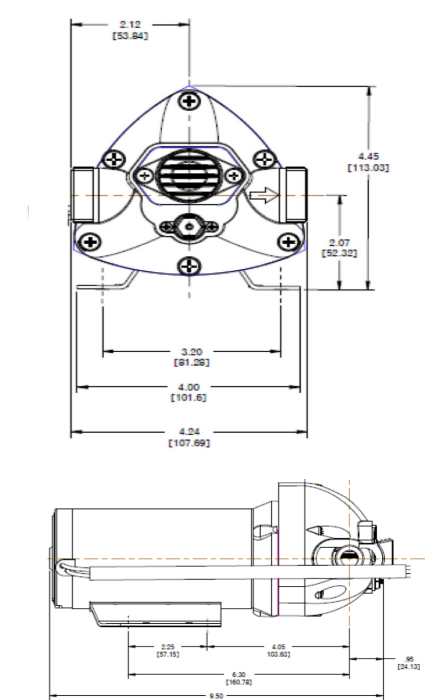



# 03 Diaphragm Pumps

MOTOR DRIVEN



## Quad Series



Flojet developed the Quad pumps to deliver higher flows up to 5 GPM (18.9 LPM) using a four-piston design with excellent self-priming capability.

### FEATURES

- Built-in pressure switch automatically starts and stops pump when discharge valve opens and closes
- Compact design and plug-in port fittings make installation easy
- Can run dry without damage and handle liquids up to 130°F (54°C)
- Excellent self-priming capability; pump may be located above the liquid level

### PERFORMANCE

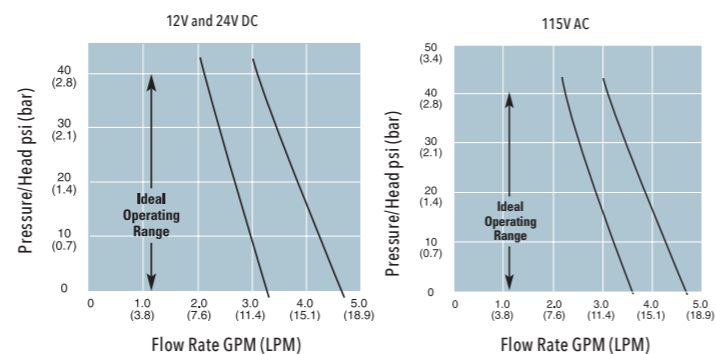

### SPECIFICATIONS

<b>VOLTAGE</b>	12V and 24V DC, 115V and 230V AC
<b>FLOW RATE</b>	3.5–5 GPM (13.2–18.9 LPM) nominal
<b>MAX PRESSURE</b>	40 psi (2.8 bar)
<b>PRESSURE SWITCH SETTING</b>	45 psi (3.2 bar) cut-out
<b>SELF-PRIMING</b>	Up to 8' (2.4m) vertical height
<b>PORTS*</b>	Plug-in ports 1/2" (13mm) or 3/4" (19mm) hose barb standard
<b>WEIGHT</b>	4lb (2kg)

\*Consult your local Flojet representative for other types of port fittings.

### DIMENSIONAL DRAWINGS

Unless otherwise stated, dimensions are in inches and (mm).

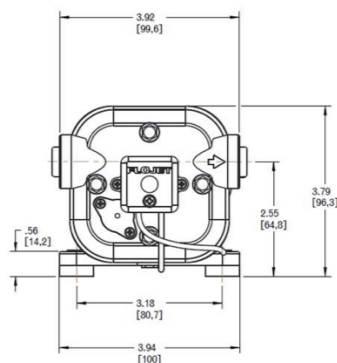
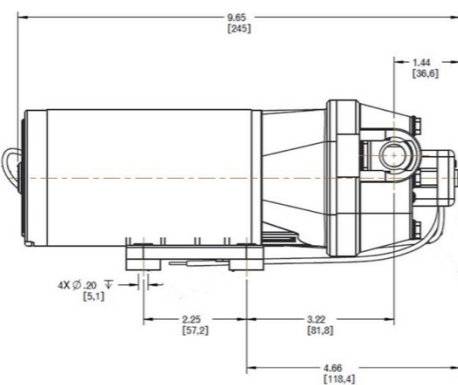

### MODELS

MODEL #	CE	VOLTAGE	OPEN FLOW	SWITCH	MAX AMP DRAW	DIAPHRAGM	CHECK VALVE	FITTINGS	COMMENTS
04100113	N/A	12V	5 GPM (19 LPM)	No	10A	Buna/PP blend	Buna	3/4" (19mm) HB ST	
04100143	R4100143	12V	5 GPM (19 LPM)	No	10A	EP/PP blend	EPDM	3/4" (19mm) HB ST	
04100505	N/A	12V	3.7 GPM (14 LPM)	No	10A	EP/PP blend	FKM	1/2" (13mm) HB ST	
04300112	N/A	12V	3.7 GPM (14 LPM)	45 psi (3.1 bar)	10A	Buna/PP blend	Buna	1/2" (13mm) HB ST	
04300142	R4300142	12V	3.7 GPM (14 LPM)	45 psi (3.1 bar)	9A	EP/PP blend	EPDM	1/2" (13mm) HB ST	
04300143	R4300143	12V	5 GPM (19 LPM)	45 psi (3.1 bar)	13A	EP/PP blend	EPDM	3/4" (19mm) HB ST	
04300500	R4300500	12V	3.7 GPM (14 LPM)	45 psi (3.1 bar)	10A	EP/PP blend	FKM	1/2" (13mm) HB ST	
04300504	R4300504	12V	5 GPM (19 LPM)	45 psi (3.1 bar)	13A	EP/PP blend	FKM	3/4" (19mm) HB ST	
04300506	R4300506	12V	5 GPM (19 LPM)	45 psi (3.1 bar)	13A	Buna/PP blend	Buna	3/4" (19mm) HB ST	
04300528	N/A	12V	3.8 GPM (14.5 LPM)	45 psi (3.1 bar)	11A	EP/PP blend	FKM	1/2" (13mm) HB ST and GH x 1/2" (13mm) MNPT	Inline connector, rocker switch
04100343	R4100343	24V	5 GPM (19 LPM)	No	4A	EP/PP blend	EPDM	3/4" (19mm) HB ST	
04300342	R4300342	24V	3.7 GPM (14 LPM)	45 psi (3.1 bar)	5A	EP/PP blend	EPDM	1/2" (13mm) HB ST	
04300343	R4300343	24V	5 GPM (19 LPM)	45 psi (3.1 bar)	5A	EP/PP blend	EPDM	3/4" (19mm) HB ST	
04100511	N/A	36V	5 GPM (19 LPM)	No	2.3A	EP/PP blend	FKM	3/4" (19mm) HB ST	
04100500	R4100500	115V AC	3.7 GPM (14 LPM)	No	1.2A	EP/PP blend	EPDM	1/2" (13mm) HB ST	
04100502	N/A	115V AC	5 GPM (19 LPM)	No	1.2A	EP/PP blend	FKM	3/4" (19mm) HB ST	
04300042	N/A	115V AC	3.7 GPM (14 LPM)	45 psi (3.1 bar)	1A	EP/PP blend	EPDM	1/2" (13mm) HB ST	
04300043	N/A	115V AC	5 GPM (19 LPM)	45 psi (3.1 bar)	1A	EP/PP blend	EPDM	3/4" (19mm) HB ST	
04300501	R4300501	115V AC	3.7 GPM (14 LPM)	45 psi (3.1 bar)	1.5A	EP/PP blend	FKM	1/2" (13mm) HB ST	
04300515	N/A	115V AC	5 GPM (19 LPM)	45 psi (3.1 bar)	1.5A	EP/PP blend	FKM	3/4" (19mm) HB ST	
04300525	N/A	115V AC	5 GPM (19 LPM)	45 psi (3.1 bar)	1.5A	EP/PP blend	FKM	3/4" (19mm) HB ST	6' (1.8m) cord
04300529	N/A	115V AC	3 GPM (11.5 LPM)	40 psi (2.8 bar)	1.8A	EP/PP blend	FKM	1/2" (13mm) HB ST	Cord/continuous duty/induction motor
04300531	N/A	115V AC	3 GPM (11.5 LPM)	40 psi (2.8 bar)	1.8A	EP/PP blend	EPDM	1/2" (13mm) HB ST	Cord/continuous duty/induction motor
I102010211	N/A	115V AC	5 GPM (19 LPM)	No	1.5A	EP/PP blend	FKM	3/4" (19mm) HB ST	6' (1.8m) cord
I103050211	N/A	115V AC	5 GPM (19 LPM)	No	1.5A	EP/PP blend	EPDM	3/4" (19mm) HB ST	6' (1.8m) cord
I304010110	N/A	115V AC	3.7 GPM (14 LPM)	45 psi (3.1 bar)	1.5A	EP/PP blend	FKM	1/2" (13mm) HB ST	6' (1.8m) cord
R4300538	R4300538	230V AC	4.5 GPM (17 LPM)	35 psi (2.4 bar)	2A	EP/PP blend	EPDM	3/4" (19mm) HB ST and 1/2" (13mm) HB ELB	Continuous duty/induction motor/
R4300539	R4300539	230V AC	3.5 GPM (13 LPM)	35 psi (2.4 bar)	2A	EP/PP blend	EPDM	3/4" (19mm) HB ST and 1/2" (13mm) HB ELB	Continuous duty/induction motor/
R4320242	R4320242	230V AC	3.7 GPM (14 LPM)	35 psi (2.4 bar)	N/A	EP/PP blend	EPDM	1/2" (13mm) HB ST	
R4320243	R4320243	230V AC	5 GPM (19 LPM)	35 psi (2.4 bar)	0.7A	EP/PP blend	EPDM	3/4" (19mm) HB ST	
R4320252	R4320252	230V AC	3.7 GPM (14 LPM)	35 psi (2.4 bar)	0.6A	EP/PP blend	FKM	1/2" (13mm) HB ST	
R4320253	R4320253	230V AC	5 GPM (19 LPM)	35 psi (2.4 bar)	0.7A	EP/PP blend	FKM	3/4" (19mm) HB ST	

# 03 Diaphragm Pumps

MOTOR DRIVEN

FLOJET®

## Versijet™ Series



The Flojet Versijet series' robust five chamber design, large robust motor, and choice of elastomers make this the ideal pump for higher flow, heavy duty applications.

### FEATURES

- Flow rates up to 6 GPM (22.7 LPM) and pressure of up to 70 psi (4.8 bar)
- Designed to handle a broad range of fluids
- Flojet's patented co-injected molded diaphragm and larger motor brushes significantly extend pump life up to 50% longer than existing Flojet Quad series diaphragm pumps
- Sealed motor and pressure switch provide years of dependable reliability
- Self-priming up to 10' (3m) (wetted)
- IPX6 rated

### PERFORMANCE

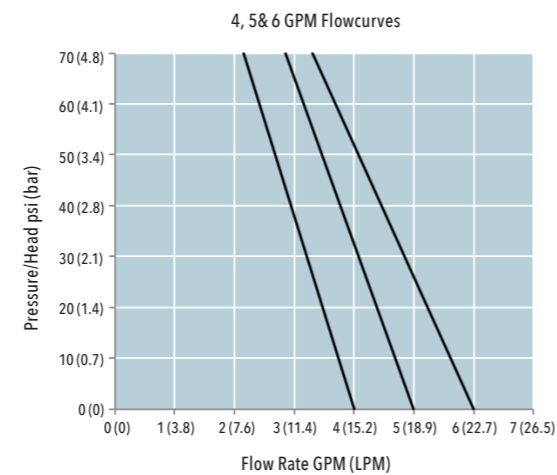

### SPECIFICATIONS

<b>PUMP DESIGN</b>	Permanent Magnet TENV (non-ventilated)
<b>VOLTAGE</b>	12V DC, 24V DC, 115V AC
<b>MAX FLOW RATE</b>	6 GPM (22.7 LPM)
<b>DUTY CYCLE</b>	Intermittent
<b>MAX PRESSURE</b>	70 psi (4.8 bar)
<b>PORTS</b>	4 GPM - 1/2" (13mm) HB 5 and 6 GPM - 3/4" (19mm) HB Other options available on request
<b>PUMP HEAD</b>	Glass-filled nylon
<b>DIAPHRAGM</b>	EP/PP blend
<b>CHECK VALVE</b>	Glass-filled nylon, EPDM
<b>LIQUID TEMPERATURE RANGE</b>	40°F (4°C) to 140°F (60°C)
<b>CERTIFICATIONS</b>	CE, RoHs, IPX6
<b>WEIGHT</b>	7.6lb (3.5kg)



### DIMENSIONAL DRAWINGS

Unless otherwise stated, dimensions are in inches and (mm).

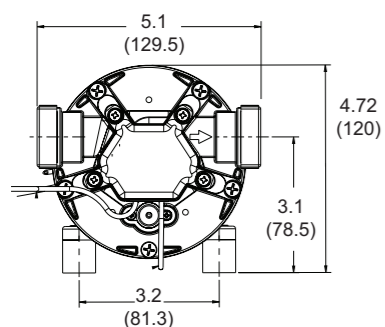
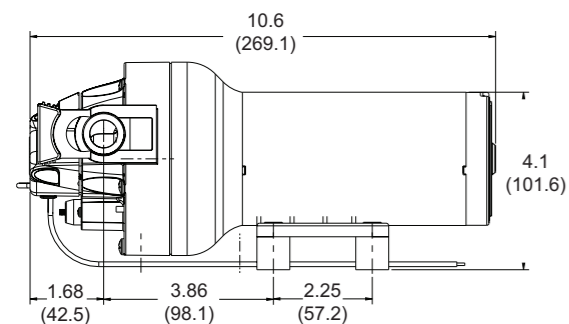

Note: 4 GPM model overall length 9.9" (252mm). All other dimensions are the same as the 5 GPM/6 GPM models.

### MODELS

MODEL #	OPEN FLOW	VOLTAGE	SWITCH	DIAPHRAGM	CHECK VALVE	MAX AMP DRAW
R8400144	4 GPM (15.1 LPM)	12V DC	70 psi (4.8 bar)	EP/PP blend	EPDM	7A
R8400134	4 GPM (15.1 LPM)	12V DC	70 psi (4.8 bar)	EP/PP blend	FKM	8A
R8410144	4 GPM (15.1 LPM)	12V DC	No	EP/PP blend	EPDM	10A
R8410134	4 GPM (15.1 LPM)	12V DC	No	EP/PP blend	FKM	7A
R8400344	4 GPM (15.1 LPM)	24V DC	70 psi (4.8 bar)	EP/PP blend	EPDM	8A
R8400334	4 GPM (15.1 LPM)	24V DC	70 psi (4.8 bar)	EP/PP blend	FKM	10A
R8410344	4 GPM (15.1 LPM)	24V DC	No	EP/PP blend	EPDM	7A
R8410334	4 GPM (15.1 LPM)	24V DC	No	EP/PP blend	FKM	8A
R8500144	5 GPM (18.9 LPM)	12V DC	70 psi (4.8 bar)	EP/PP blend	EPDM	10A
R8500134	5 GPM (18.9 LPM)	12V DC	70 psi (4.8 bar)	EP/PP blend	FKM	7A
R8510144	5 GPM (18.9 LPM)	12V DC	No	EP/PP blend	EPDM	8A
R8510134	5 GPM (18.9 LPM)	12V DC	No	EP/PP blend	FKM	10A
R8500344	5 GPM (18.9 LPM)	24V DC	70 psi (4.8 bar)	EP/PP blend	EPDM	12A
R8500334	5 GPM (18.9 LPM)	24V DC	70 psi (4.8 bar)	EP/PP blend	FKM	16A
R8510344	5 GPM (18.9 LPM)	24V DC	No	EP/PP blend	EPDM	18A
R8510334	5 GPM (18.9 LPM)	24V DC	No	EP/PP blend	FKM	12A
R8600144	6 GPM (22.7 LPM)	12V DC	70 psi (4.8 bar)	EP/PP blend	EPDM	16A
R8600134	6 GPM (22.7 LPM)	12V DC	70 psi (4.8 bar)	EP/PP blend	FKM	18A
R8610144	6 GPM (22.7 LPM)	12V DC	No	EP/PP blend	EPDM	12A
R8610134	6 GPM (22.7 LPM)	12V DC	No	EP/PP blend	FKM	16A
R8600344	6 GPM (22.7 LPM)	24V DC	70 psi (4.8 bar)	EP/PP blend	EPDM	18A
R8600334	6 GPM (22.7 LPM)	24V DC	70 psi (4.8 bar)	EP/PP blend	FKM	12A
R8610344	6 GPM (22.7 LPM)	24V DC	No	EP/PP blend	EPDM	16A
R8610334	6 GPM (22.7 LPM)	24V DC	No	EP/PP blend	FKM	18A

Note: Some versions available with Polypropylene pumpheads. Please enquire with factory for details.  
115V AC models available for many of the configurations

# 03 Diaphragm Pumps

MOTOR DRIVEN

FLOJET®

## AC Variable Speed Drive Series



### FOR INTERNATIONAL & US MARKETS

The AC Variable Speed Drive constant pressure pump system matches motor speed to system demand. As more liquid is needed, the motor responds to increase flow. Conversely, as the demand lessens, the motor slows to a "super quiet" speed, always maintaining a constant system pressure. The result is exceptionally stable flow and reduced amp draw. The Flojet AC VSD sensor-controlled pumps provide stable, constant-pressure operation on any AC application. Operation from no flow to maximum flow is proportionally controlled, eliminating unwanted pump switch cycling and the need for an accumulator tank.

### FEATURES

- Maintains steady fluid pressure in response to variable flow demand
- Conserves energy, low amp draw
- Quiet running under normal use
- Automatically adjusts motor speed to maintain pressure
- Improves overall system performance
- Eliminates bulky accumulator tank for limited space requirements

### PERFORMANCE

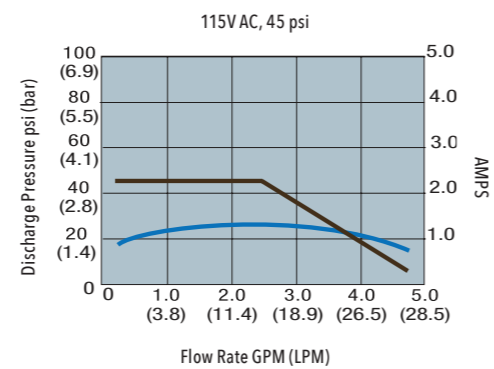

### DIMENSIONAL DRAWINGS

Unless otherwise stated, dimensions are in inches and (mm).

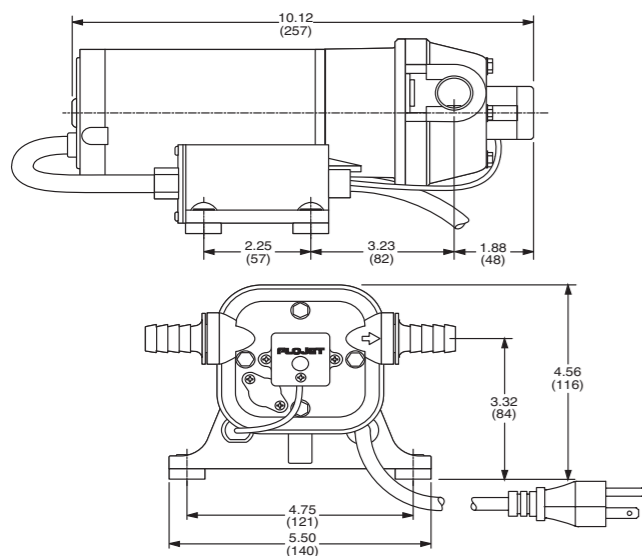

### SPECIFICATIONS

<b>PUMP DESIGN</b>	Positive displacement diaphragm (4 piston)
<b>VOLTAGE</b>	115V AC
<b>MAX AMP DRAW</b>	1.5 A
<b>MAX FLOW RATE</b>	5 GPM (19 LPM) open flow
<b>DUTY CYCLE</b>	Intermittent
<b>CYCLES</b>	60 Hz
<b>MOTOR</b>	Permanent magnet rectified
<b>MAX LIQUID TEMPERATURE</b>	130°F (55°C)
<b>CERTIFICATIONS</b>	UL listed, NSF
<b>DIMENSIONS</b>	4-5/16" high x 10-1/8" long x 5-1/2" wide (110mm x 257mm x 140mm)
<b>WEIGHT</b>	6.63lb (3kg)
<b>WARRANTY</b>	1 year

### MODELS

MODEL #	CE	OPEN FLOW	SWITCH	DIAPHRAGM	CHECK VALVE	FITTINGS
04524500A	No	5 GPM (18.9 LPM)	45 psi (3.1 bar)	EP/PP alloy	EPDM	3/8"-1/2" (10-13mm) HB
04524501A	No	5 GPM (18.9 LPM)	30 psi (2.1 bar)	EP/PP alloy	EPDM	3/8"-1/2" (10-13mm) HB

# 03 Diaphragm Pumps

AIR DRIVEN

**FLOJET®**

## G57 Series



### FOR INTERNATIONAL & US MARKETS

Innovative compact design features a patented shuttle valve that eliminates stalling and provides a long life. Features a chemically resistant polypropylene body with a choice of EP/PP blend, FKM or FFKM elastomers, as well as quick disconnect liquid and gas port fittings for easy installation.

### FEATURES

- Highest flow rate for any air pump of comparable size
- Stall-proof design with patented shuttle valve
- Easy installation with all quick disconnect ports
- Robust design with durable integral mounting
- Sanitary design with inset molded diaphragm
- Leak resistant radial seals, no critical O-ring seals
- Quiet operation with large exhaust muffler

### PERFORMANCE

EP/PP blend or FKM Material with 1/2" (13mm) Ports

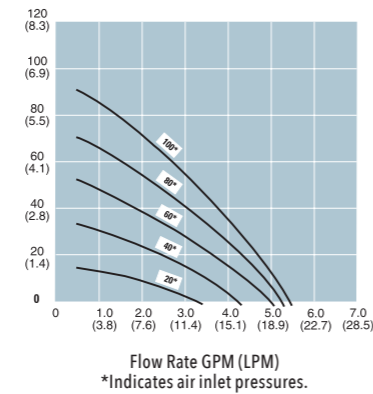

### DIMENSIONAL DRAWINGS

Unless otherwise stated, dimensions are in inches and (mm).

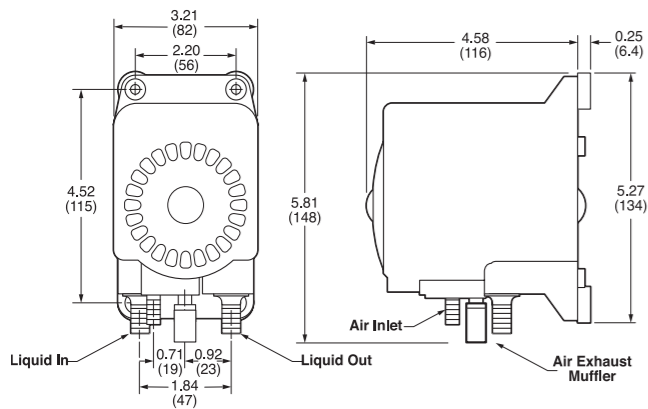

### SPECIFICATIONS

<b>PUMP DESIGN</b>	Air-operated positive displacement double diaphragm pump
<b>MAX FLOW RATE</b>	5 GPM (18.9 LPM)
<b>PRESSURE</b>	20-100 psi (1.4-6.9 bar) (same as inlet air pressure)
<b>PORTS</b>	Liquid - 3/8" (10mm), 1.2" (13mm) and 3/4" (19mm) HB; 3/8" (10mm) and 1/2" (13mm) MNPT Air inlet - 1/4" (6mm) HB
<b>BODY</b>	Polypropylene
<b>DIAPHRAGM</b>	EP/PP blend, FKM, FFKM
<b>CHECK VALVES</b>	EP/PP blend, FKM, FKM Extreme
<b>CHECK VALVE SPRING</b>	Hasteloy C
<b>WEIGHT</b>	1.2lb (0.5kg)

### MODELS

MODEL #	OPEN FLOW	DIAPHRAGM	CHECK VALVE	LIQUID FITTINGS	AIR INLET
G573000	5 GPM (18.9 LPM)	FKM	Polypropylene	None	None
G573205	5 GPM (18.9 LPM)	FKM	Polypropylene	3/8"-1/2" (10-13mm) HB ST	1/4" (6mm) HB brass
G573215	5 GPM (18.9 LPM)	FKM	Polypropylene	1/2" (13mm) HB ST	1/4" (6mm) HB brass
G573225	5 GPM (18.9 LPM)	FKM	Polypropylene	3/4" (19mm) HB ST	1/4" (6mm) HB brass
G573145	5 GPM (18.9 LPM)	FKM	Polypropylene	1/2" (13mm) OD JG	1/4" (6mm) HB brass
G573185	5 GPM (18.9 LPM)	FKM	Polypropylene	3/8" (10mm) MNPT ST	1/4" (6mm) HB brass
G573175	5 GPM (18.9 LPM)	FKM	Polypropylene	1/2" (13mm) MNPT ST	1/4" (6mm) HB brass
G575005	5 GPM (18.9 LPM)	EP/PP blend	Polypropylene	None	1/4" (6mm) HB brass
G575205	5 GPM (18.9 LPM)	EP/PP blend	Polypropylene	3/8" (10mm) HB ST	1/4" (6mm) HB brass
G575215	5 GPM (18.9 LPM)	EP/PP blend	Polypropylene	1/2" (13mm) HB ST	1/4" (6mm) HB brass
G575225	5 GPM (18.9 LPM)	EP/PP blend	Polypropylene	3/4" (19mm) HB ST	1/4" (6mm) HB brass
G575145	5 GPM (18.9 LPM)	EP/PP blend	Polypropylene	1/2" (13mm) OD JG	1/4" (6mm) HB brass
G575185	5 GPM (18.9 LPM)	EP/PP blend	Polypropylene	3/8" (10mm) MNPT ST	1/4" (6mm) HB brass
G575175	5 GPM (18.9 LPM)	EP/PP blend	Polypropylene	1/2" (13mm) MNPT ST	1/4" (6mm) HB brass
G57C002	5 GPM (18.9 LPM)	FFKM	Polypropylene	None	1/4" (6mm) HB brass
G57C202	5 GPM (18.9 LPM)	FFKM	Polypropylene	3/8"-1/2" (10-13mm) HB ST	1/4" (6mm) HB brass
G57C203	5 GPM (18.9 LPM)	FFKM	Polypropylene	3/8"-1/2" (10-13mm) HB ST	1/4" (6mm) HB EL brass
G57C212	5 GPM (18.9 LPM)	FFKM	Polypropylene	1/2" (13mm) HB ST	1/4" (6mm) HB brass
G57C213	5 GPM (18.9 LPM)	FFKM	Polypropylene	1/2" (13mm) HB ST	1/4" (6mm) HB EL brass
G57C222	5 GPM (18.9 LPM)	FFKM	Polypropylene	3/4" (19mm) HB ST	1/4" (6mm) HB brass
G57C223	5 GPM (18.9 LPM)	FFKM	Polypropylene	3/4" (19mm) HB ST	1/4" (6mm) HB EL brass
G57C182	5 GPM (18.9 LPM)	FFKM	Polypropylene	3/8" (10mm) MNPT ST	1/4" (6mm) HB brass
G57C172	5 GPM (18.9 LPM)	FFKM	Polypropylene	1/2" (13mm) MNPT ST	1/4" (6mm) HB brass
G57C152	5 GPM (18.9 LPM)	FFKM	Polypropylene	3/8" (10mm) OD JG	1/4" (6mm) HB brass
G57C412	5 GPM (18.9 LPM)	FFKM	Polypropylene	1/2" (13mm) OD JG	1/4" (6mm) HB brass

# 03 Diaphragm Pumps

AIR DRIVEN

**FLOJET®**

## G70 & G71



### FOR INTERNATIONAL & US MARKETS

This ATEX Certified Air operated pump is designed to be the ultimate in performance and reliability. Our robust design combines innovative features and relentless testing to offer a pump that has a long, trouble free service life.

### FEATURES

- Capable of air inlet pressures up to 100 psi (6.9 bar)
- Robust design with durable integral mounting
- Patented shuttle valve eliminates stalling when used with dry air
- Capable of passing solids up to 1/8" (3.2mm) diameter easily with large clog-free check valves
- Corrosion resistant materials capable of handling a wide range of chemicals
- Leak resistant made from Viton® Extreme™ O-ring seals
- Ease of installation with all plug-in ports
- John Guest® hose barb, NPT and elbow configurations available
- Low air consumption compared with other pumps in its class

### APPLICATIONS

- Chemical transfer and dispensing
- Solvent applications
- Parts washers
- Ink transfer
- Car wash systems
- Any application requiring ATEX approval

### PERFORMANCE

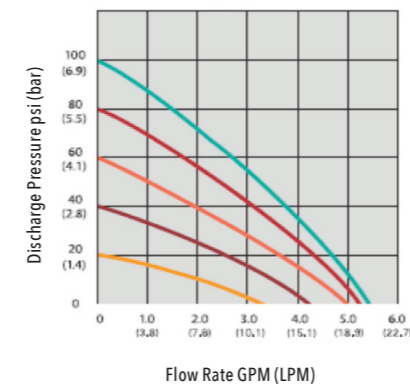

### DIMENSIONAL DRAWINGS

Unless otherwise stated, dimensions are in inches and (mm).

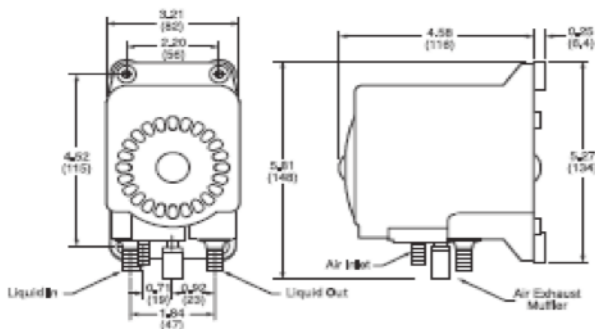

### SPECIFICATIONS

<b>PUMP DESIGN</b>	Air-operated positive displacement double diaphragm pump
<b>MAX FLOW RATE</b>	5 GPM (18.9 LPM)
<b>PRESSURE</b>	20-100 psi (1.4-6.9 bar) (same as inlet air pressure)
<b>PORTS</b>	Liquid - 3/8" (10mm), 1.2" (13mm) and 3/4" (19mm) HB; 3/8" (10mm) and 1/2" (13mm) MNPT Air inlet - 1/4" (6mm) HB
<b>BODY</b>	Polypropylene/nylon (G71)
<b>DIAPHRAGM</b>	FFKM
<b>CHECK VALVES</b>	Polypropylene/nylon (G71)
<b>CHECK VALVE SPRING</b>	Hasteloy C
<b>WEIGHT</b>	1.2lb (0.5kg)

### MODELS

MODEL #	OPEN FLOW	DIAPHRAGM	CHECK VALVE	LIQUID FITTINGS	AIR INLET
G70C002	5 GPM (18.9 LPM)	FFKM	Polypropylene	None	1/4" (6mm) HB brass
G70C162	5 GPM (18.9 LPM)	FFKM	Polypropylene	3/8"-1/2" (10-13mm) HB ST & EL	1/4" (6mm) HB brass
G70C202	5 GPM (18.9 LPM)	FFKM	Polypropylene	3/8"-1/2" (10-13mm) HB ST	1/4" (6mm) HB brass
G70C222	5 GPM (18.9 LPM)	FFKM	Polypropylene	3/4" (19mm) HB ST	1/4" (6mm) HB brass
G70K002	5 GPM (18.9 LPM)	FFKM	Nylon	None	1/4" (6mm) HB brass
G70K162	5 GPM (18.9 LPM)	FFKM	Nylon	3/8"-1/2" (10-13mm) HB ST & EL	1/4" (6mm) HB brass
G70K202	5 GPM (18.9 LPM)	FFKM	Nylon	3/8"-1/2" (10-13mm) HB ST	1/4" (6mm) HB brass
G70K422	5 GPM (18.9 LPM)	FFKM	Nylon	3/8"-1/2" (10-13mm) HB ST	1/4" (6mm) HB brass
G71K002	5 GPM (18.9 LPM)	FFKM	Nylon	None	1/4" (6mm) HB brass
G71K162	5 GPM (18.9 LPM)	FFKM	Nylon	3/8"-1/2" (10-13mm) HB ST & EL	1/4" (6mm) HB brass
G71K202	5 GPM (18.9 LPM)	FFKM	Nylon	3/8"-1/2" (10-13mm) HB ST	1/4" (6mm) HB brass
G71K422	5 GPM (18.9 LPM)	FFKM	Nylon	3/8"-1/2" (10-13mm) HB ST	1/4" (6mm) HB brass

### INSTALLATION RECOMMENDATIONS

- Liquid inlet port must be equal to or larger than the liquid outlet port
- Rubber grommets are provided for secure snug fit on mounting. All four mounting holes should be used.

# 03 Diaphragm Pumps

AIR DRIVEN



## G57 Series Dual High Flow



### FOR INTERNATIONAL & US MARKETS

#### FEATURES

- Flows to 10 GPM (38 LPM)
- Chemically resistant polypropylene housings with FKM and EP/PP blend elastomers
- Easy installation with 1/2" (13mm) dual and 3/4" (19mm) quatro pump manifolds
- Duplex diaphragm design
- Patented shuttle valves eliminates stalling
- Compact size

#### PERFORMANCE

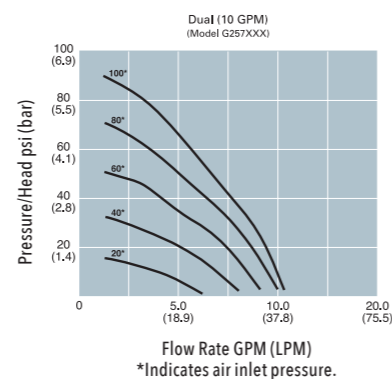

#### DIMENSIONAL DRAWINGS

Unless otherwise stated, dimensions are in inches and (mm).

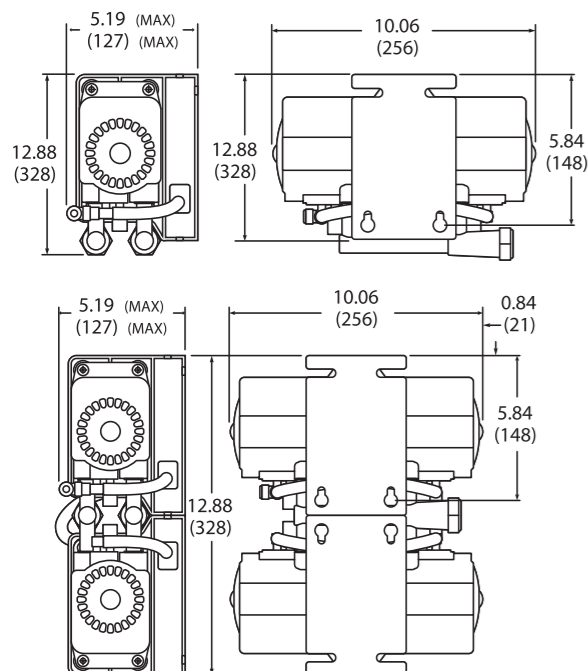

#### MODELS

MODEL #	CE	OPEN FLOW	DIAPHRAGM	LIQUID FITTINGS	AIR INLET
G257301A	Yes	10 GPM (38 LPM)	FKM	1/2" (13mm) NPFT	1/4" (6mm) HB ST
G257302A	Yes	10 GPM (38 LPM)	FKM	1/2" (13mm) NPFT	1/4" (6mm) QD EL
G257501A	Yes	10 GPM (38 LPM)	EP/PP blend	1/2" (13mm) NPFT	1/4" (6mm) HB ST
G257502A	Yes	10 GPM (38 LPM)	EP/PP blend	1/2" (13mm) NPFT	1/4" (6mm) QD EL
G577000A*	Yes	5 GPM (19 LPM)	EP/PP blend	None	None
G578000A**	Yes	5 GPM (19 LPM)	FKM	None	None

\* EP/PP blend reverse flow for dual G57  
\*\* FKM reverse flow for dual G57

#### SPECIFICATIONS

<b>PUMP DESIGN</b>	Positive displacement double diaphragm
<b>MAX FLOW RATE (DUAL)</b>	10 GPM (38 LPM)
<b>PRESSURE</b>	20-100 psi (1.4-6 bar)
<b>SELF-PRIMING</b>	15' (4.5m) dry, 20' (6.1m) wet
<b>CHECK VALVE</b>	Polypropylene
<b>LIQUID TEMPERATURE RANGE</b>	40°F (4.4°C) to 140°F (60°C)
<b>MAX LIQUID INLET PRESSURE</b>	30 psi (2.1 bar)
<b>AIR SUPPLY PRESSURE</b>	20-100 psi (1.4-6 bar)
<b>MAX NOISE</b>	90 db

IOM #81000-354

## N5100 Series



### FOR INTERNATIONAL & US MARKETS

Flojet air-operated diaphragm pumps offer excellent self-priming capability. Pumps can be located above the supply tank. A suction-side foot valve is recommended for best operation. Liquid pressure is regulated by supply air pressure. No bypass or pressure relief plumbing is necessary. Choice of EP/PP blend, Buna, or FKM elastomers provide a wide range of chemical compatibility. Quick disconnect liquid and gas port fittings provide easy installation.

#### FEATURES

- Compact design with plug-in hose connections for quick installation
- Variety of elastomers to ensure chemical compatibility
- Variable capacity from zero to the maximum flow
- No pressure relief or bypass plumbing required
- Excellent self-priming; pump may be located above the liquid level

#### PERFORMANCE

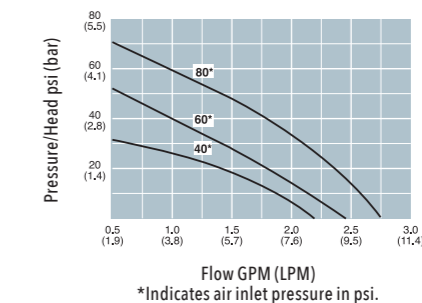

#### DIMENSIONAL DRAWINGS

Unless otherwise stated, dimensions are in inches and (mm).

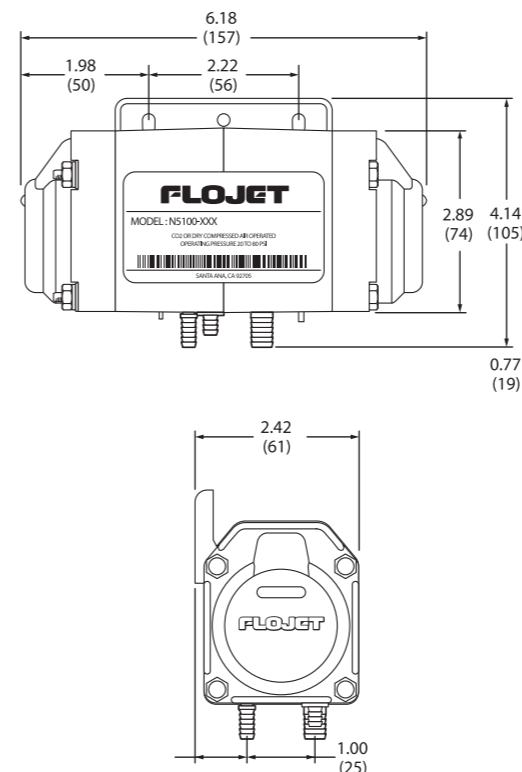

#### MODELS

MODEL #	CE	OPEN FLOW	DIAPHRAGM	CHECK VALVE
N5100010	Yes	2.5 GPM (9.5 LPM)	Buna	Buna
N5100020	Yes	2.5 GPM (9.5 LPM)	FKM	FKM
N5100040	Yes	2.5 GPM (9.5 LPM)	EP/PP blend	EP/PP blend
N5100050	Yes	2.5 GPM (9.5 LPM)	Buna/PP blend	Buna/PP blend
N5100500*	Yes	2.5 GPM (9.5 LPM)	EP/PP blend	EP/PP blend

\*Teflon O-ring

#### SPECIFICATIONS

<b>PUMP DESIGN</b>	Air-operated positive displacement double diaphragm pump
<b>MAX FLOW RATE</b>	2.5 GPM (9.5 LPM)
<b>PRESSURE</b>	20-75 psi (1.4-5.5 bar)
<b>SELF-PRIMING</b>	28' (8.5m) dry, 32' (9.8m) wet
<b>PORTS</b>	Liquid - 3/8" (10mm), Air - 1/4" (6mm)
<b>LIQUID FITTINGS</b>	3/8" (10mm) HB ST
<b>AIR INLET/OUTLET</b>	1/4" (6mm) HB ST
<b>WETTED PARTS</b>	Buna, EP/PP blend, buna/PP blend or FKM for diaphragms and valves; acetal copolymer for housing
<b>GAS/AIR CONSUMPTION</b>	Air supply must be oil-free and dry 40 psi at 1 GPM - 0.5 CFM, 60 psi at 1 GPM - 0.6 CFM, 80 psi at 1 GPM - 0.8 CFM

IOM #81000-363

# 03 Diaphragm Pumps

ACCESSORIES & FITTINGS

FLOJET®

## Permanent Magnet Motors



### FOR INTERNATIONAL & US MARKETS

Flojet manufactures a wide range of 3" (76mm) diameter permanent magnet motors. These are designed as a more cost-effective alternative to larger series wound or induction-type motors. They also offer flexibility of speed in the range of 1000 to 5000 rpm. Low heat rise and high efficiency ensures long and reliable service life. The ease with which these motors can be adapted to any application is enhanced by the availability of various motor lengths and shaft configurations. The fact that the motors are bidirectional increases their versatility. Most of our motors have the appropriate agency approvals including UL, CSA and CE.

### FEATURES

- Highly efficient permanent magnet design
- Combines advantages of low amp draw heat rise with high torque and low speed
- Diamond-turned commutator
- Delivers up to 1/8 HP in compact 3" (76mm) diameter
- 6V, 12V, 24V, 32V, 36V, 115V, 230V and 240V AC or DC
- Lightweight, double insulated armatures
- High starting torque – up to 600% of rated torque
- Speed control capability
- Available with internal solid state rectifier (AC models only)
- Instant reversibility (DC voltages)
- Thermo protection available
- Dynamic braking capability
- UL recognized (115V AC models only)
- Partial or full suppression available with CE certification

### MODELS

STACK LENGTH (APPROX.)	A	MHP
1/2" (13mm)	2.9" (73mm)	20
7/8" (22mm)	3.25" (83mm)	50
1-1/4" (32mm)	3.7" (94mm)	75
1-7/8" (47mm)	4.4" (112mm)	100

### SPECIFICATIONS

<b>MOTOR DESIGN</b>	Permanent magnet
<b>VOLTAGE</b>	6V-230V DC or rectified AC
<b>SIZE</b>	3" (76mm) diameter
<b>STACK LENGTH</b>	1/2"-2" (13mm-51mm)
<b>MAX HORSEPOWER</b>	1/8 HP
<b>DUTY CYCLE</b>	Continuous or intermittent
<b>SPEED</b>	1100-5000 rpm
<b>INSULATION</b>	Class B standard
<b>BEARINGS</b>	Sleeve or ball bearing
<b>ENCLOSURE</b>	Totally enclosed; totally enclosed, fan-cooled



### WARNING

Explosion hazard. Motor can spark.  
Do not use where flammable vapors are present.

### DIMENSIONAL DRAWINGS

Unless otherwise stated, dimensions are in inches and (mm).

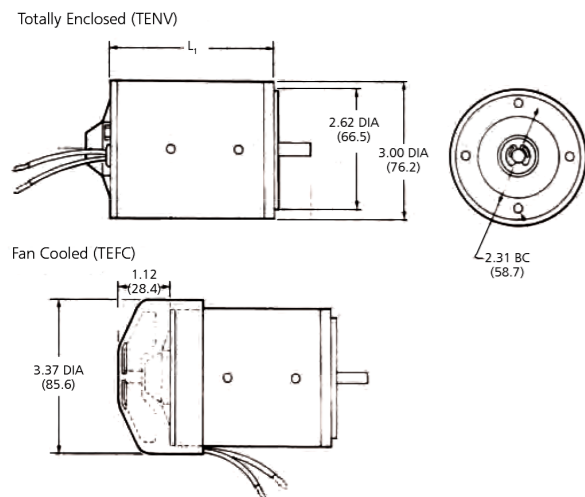

### MOTOR SHAFT CONFIGURATION

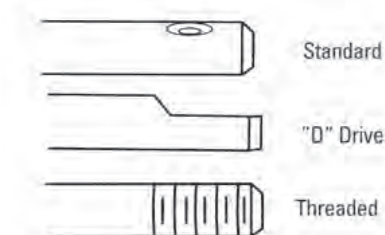

## 1720/1740/1745 Series Inlet Strainers



### DIMENSIONAL DRAWINGS

Unless otherwise stated, dimensions are in inches and (mm).

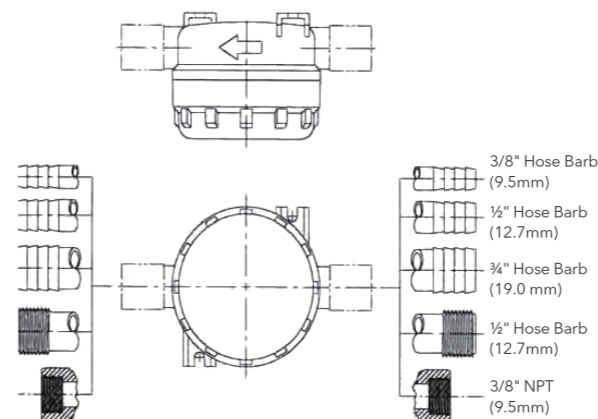
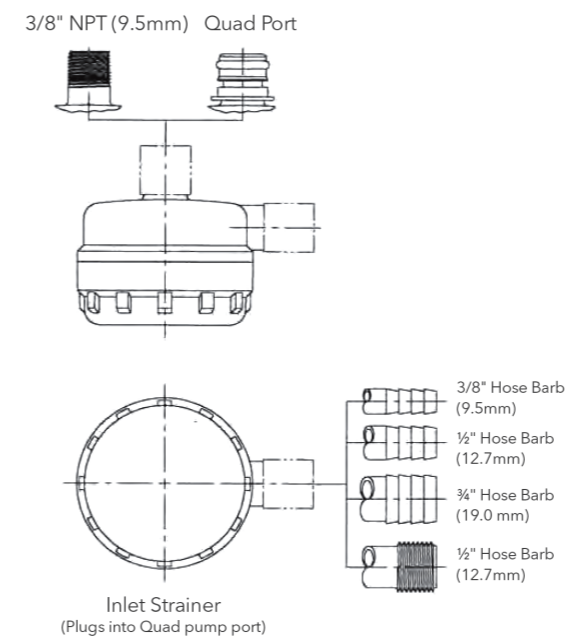

### FOR INTERNATIONAL & US MARKETS

### FEATURES

- Low profile design for space-saving installation
- Very strong, reinforced plastic base with clear cover
- Wide variety of port configurations from 3/8" (10mm) to 3/4" (19mm)

### MODELS

MODEL #	DESCRIPTION
01720-000	3/4" (19mm) x 3/4" (19mm) hose barb SS 20M
01720-002	1/2" (13mm) x 1/2" (13mm) hose barb SS 20M
01720-023	3/8" (10mm) HB x 3/8" (10mm) NPTM 90° SS 20M
01720-102	1/2" (13mm) x 1/2" (13mm) hose barb PP 20M
01720-103	3/8" (10mm) x 3/8" (10mm) hose barb PP 20M
01720-112	1/2" (13mm) x quad port 90° PP 20M
01720-123	3/8" (10mm) HB x 3/8" (10mm) NPTM 90° PP 20M
01720-375	3/8" (10mm) NPTF x 3/8" (10mm) NPTF SS 20M
01740-000	3/4" (19mm) x 3/4" (19mm) hose barb SS 40M
01740-002	1/2" (13mm) x 1/2" (13mm) hose barb SS 40M
01740-003	3/8" (10mm) x 3/8" (10mm) hose barb SS 40M
01740-004	1/2" (13mm) x 1/2" (13mm) SS 40M
01740-010	3/4" (19mm) x quad port 90° SS 40M
01740-012	1/2" (13mm) x quad port 90° SS 40M
01740-014	1/2" (13mm) x quad port 90° SS 40M
01740-300	Snap Fit Strainer Quick Connect male X Quad Port
01740-375	3/8" (10mm) NPTF x 3/8" (10mm) NPTF SS 40M
017450-000S	Strainer inline 3/4" (19mm) HB x 3/4" (19mm) HB SS 40M PETG VIT
017450-10S	Strainer inline 3/4" (19mm) HB x quad port 90° 40M PETG VIT
017450-12S	Strainer inline 1/2" (13mm) HB x quad port 90° 40M PETG VIT
017450-23S	Strainer inline 3/8" (10mm) HB x 3/8" (10mm) MNPT SS 40M PETG VIT

SS - Stainless Steel PP - Polypropylene M - Mesh

### SPECIFICATIONS

<b>BASE</b>	Polypropylene, black
<b>COVER</b>	Polysulfane, smoke-tinted
<b>SCREEN</b>	Stainless steel - 20 and 40 mesh Polypropylene - 20 mesh
<b>O-RINGS</b>	Buna-N FDA compound
<b>MAX TEMPERATURE</b>	160°F (70°C)
<b>DIMENSIONS</b>	2-3/4" (70mm) diameter x 2-1/4" (56mm) high 4-3/4" (121mm) max port to port (3/4" hose barb) plug-in style, 3-3/4" (96mm) max length

## Electric Pump Fittings

## NYLON BARBED STRAIGHT/ELBOW

For use with all Duplex II Series pumps (3/8" [10mm] NPT only).

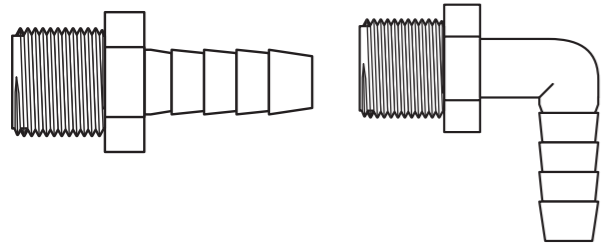

## PLASTIC (POLYPROPYLENE, EPDM)\* INLETS &amp; OUTLETS

For use with all Triplex, Quad and G57 Series pumps.

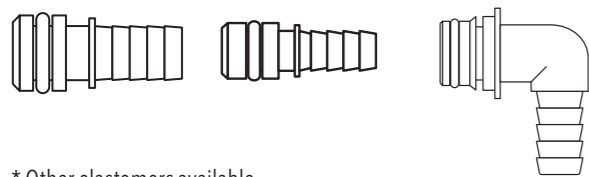

\* Other elastomers available.

## FOR INTERNATIONAL &amp; US MARKETS

## MODELS

PART # (STRAIGHT)	PART # (ELBOW)	DESCRIPTION
91010-032	91010-033	3/8" (10mm) NPTM x 1/4" (6mm) barb
91010-004	91010-003	1/4" (6mm) NPTM x 3/8" (10mm) barb
91010-002	91010-001	3/8" (10mm) NPTM x 3/8" (10mm) barb
91010-034	91010-025	1/4" (6mm) NPTM x 3/8" (10mm) barb
91010-006	91010-005	3/8" (10mm) NPTM x 1/2" (13mm) barb
91010-053	91010-052	1/4" (6mm) NPTM x 1/4" (6mm) barb
91006-477A	N/A	Wire harness 9' (3m) with fuse rocker switch and in-line connector

## MODELS

PART # (STRAIGHT)	PART # (ELBOW)	DESCRIPTION
20381-000	20381-008	Quad port x 1/2" (13mm) - 14 male straight
20381-002	20381-009	Quad port x 1/2" (13mm) hose barb
20381-006	20381-010	Quad port x 3/4" (19mm) hose barb
20381-007	N/A	Quad port x garden hose adapter

## Gas Pump Fittings

## STAINLESS STEEL INLETS &amp; OUTLETS (LIQUID FITTINGS)

For use with all 5100 Series pumps.

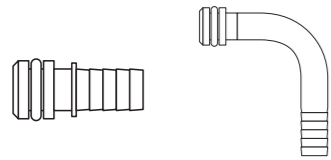
BRASS CO<sub>2</sub>/AIR INLETS WITH SHUT-OFF VALVE (AIR FITTINGS)

For use with all 5100 and G Series pumps.

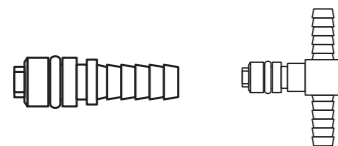
PLASTIC (CELCON) CO<sub>2</sub>/AIR INLETS

For use with all 5100 and G Series pumps.

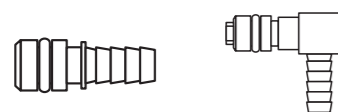

## MODELS

PART # (STRAIGHT)	PART # (ELBOW)	DESCRIPTION
20324-030	20607-100	1/4" (6mm) hose barb
20325-030	20608-100	3/8" (10mm) hose barb
20606-100	N/A	1/2" (13mm) hose barb

## MODELS

PART #	DESCRIPTION
1510-000	1/4" (6mm) hose barb, straight
1520-000	1/4" (6mm) hose barb, tee
1521-000	1/4" (6mm) hose barb, elbow

## MODELS

PART #	DESCRIPTION
20325-033	1/4" (6mm) hose barb, straight



# Flexible Impeller Pumps 04

Introduction  
Epoxy / Phenolic Plastic  
Bronze  
Stainless Steel

Introduction to Sanitary Pumps  
Stainless Steel Sanitary Pumps  
Model Variants  
Impeller Replacement Guide



# 04 Flexible Impeller Pumps

INTRODUCTION



## Introduction

There are probably few parts of the world where the Xylem Jabsco family of products is not in use or where our brands are not known.

The reason is simple: "Make good fit-for-purpose products and you will get a good name."

This catalog is designed to help you understand the basics of a flexible impeller pump (FIP) and supply you with a quick reference guide, enabling you to choose the correct pump for the application.

### JACK ART BRIGGS STREETER COMPANY

- To come up with the name Jabsco, these inventors used the first letter from each of their names and added the "co", to be Jabsco. Jabsco pump company formed in Burbank, California.
- First pump designed in 1938.
- The patent for the flexible impeller was issued in 1938.
- Designed in response to a specific customer requirement for condensate removal from air conditioning systems.
- The FIP principle has been applied to a diverse range of applications such as engine cooling systems, bulk milk transfer, food processing and industrial applications.

### THE HISTORY. THE ORIGINAL.

Feb. 6, 1940.

A. M. BRIGGS

2,189,356

ROTARY PUMP

Filed Aug. 2, 1938

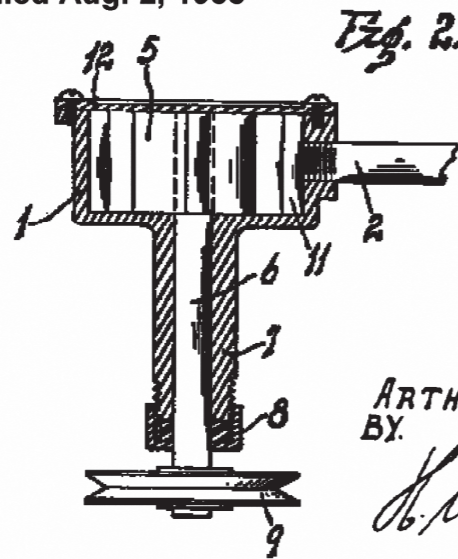
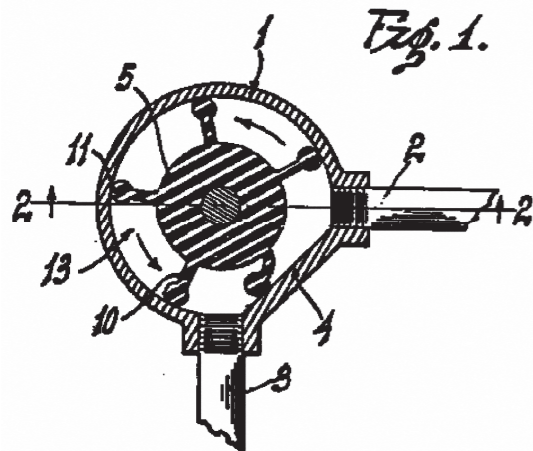

INVENTOR.  
ARTHUR M. BRIGGS.  
BY.  
*H. A. Duchman*  
ATTORNEY.

## Flexible Impeller Product Range

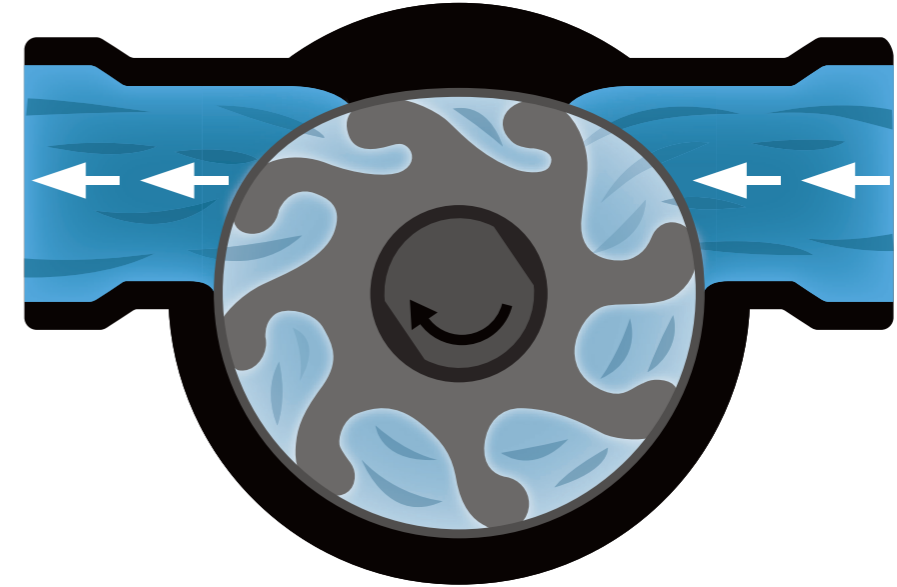

### HOW A FLEXIBLE IMPELLER WORKS

- As the impeller rotates, the impeller blades leaving the cam straighten, causing the cell volume to increase. This causes a partial vacuum which allows atmospheric pressure to push the liquid into the pump.
- The blades form an almost perfect seal, which also allows the impeller to "pump" air.
- The impeller continues to rotate, transferring the fluid in the cells that now have constant volume.
- Now the vanes reach the other side of the cam, and the cell volume decreases which forces the fluid out through the discharge port.
- This happens thousands of times per minute, producing a continuous, even flow.

### FEATURES

- Self-priming: will lift fluid up to 22' (6.7m) when wet
- Will not air lock: pump will continue to operate even when air passes through the system
- Viscous liquids handling: will easily pump thin or thick liquids
- Pulsation-free flow: delivers a smooth, even flow
- Non-shear action: will handle delicate fluids
- Hard solid handling: passes hard solids or abrasives with minimal wear or damage
- Few moving parts: easy to maintain, so less downtime
- Compact: will provide high flows from a small-size pump
- Competitive: lower-cost installation and less maintenance than other competing pump types

### SPECIFICATIONS

PUMP DESIGN	Pedestal, close-coupled, pump head kits
VOLTAGE	50/60Hz - 12V, 24V DC and 115V, 230V AC
MAX FLOW RATE	185 GPM (700 LPM)
MAX PRESSURE	60 psi (4.1 bar)
PORTS	Hose fitting, internal-external NPT/BSP, clamp, ACME
BODY	Epoxy, phenolic, bronze, stainless steel
SEAL	Buna, nitrile, FKM lip seals, mechanical carbon-on-ceramic, tungsten carbide
VISCOSITY	1-50,000 centiPoise (Cp)
IMPELLER	Neoprene, 3A neoprene, nitrile, 3A nitrile, FKM, 3A EPDM
IMPELLER RATINGS	Standard, medium, high pressure



### GAS WARNING

No pump manufactured by Xylem should be used for gasoline or any fluid with a flash point below 100°F (38°C).

# 04 Flexible Impeller Pumps

EPOXY / PHENOLIC PLASTIC



## 12310 Series Phenolic Plastic Flex Pump



Use where corrosion-resistant plastic material, self-priming, flow and debris tolerance are desired. Use neoprene for water and general-purpose pumping. A nitrile impeller is ideal for oil-based products. Use FKM for hydrocarbons and solvents. Motor is not explosion-proof. Do not run dry.



### SPECIFICATIONS

<b>VOLTAGE</b>	60Hz - 115V AC, single phase, non-CE
<b>MAX FLOW RATE</b>	4 GPM (15.1 LPM)
<b>MAX PRESSURE</b>	17 psi (1.2 bar), 39' (11.9m) of water
<b>SELF-PRIMING</b>	5-7' (1.5-2.1m) dry, 10-14' (3-4.3m) wet
<b>PORTS</b>	3/8" (10mm) NPTF, 3/4" (19mm) male garden hose thread
<b>MOTOR</b>	PMDC rectified, intermittent duty
<b>BODY</b>	Phenolic
<b>LIQUID TEMPERATURE RANGE</b>	Neoprene - 45°F (7°C) to 180°F (82°C) Nitrile - 50°F (10°C) to 180°F (82°C)
<b>SHAFT</b>	Stainless steel
<b>SEAL</b>	Buna lip type
<b>IMPELLER</b>	Neoprene, nitrile
<b>DIMENSIONS</b>	3-7/16" high x 5" long x 7" wide (87mm x 126mm x 177mm)
<b>WEIGHT</b>	5.8lb (2.6kg)

### MODELS

MODEL #	CE	VOLTAGE	IMPELLER	STYLE
12310-0001	No	115V AC	Neoprene	MPU
12310-0003	No	115V AC	Nitrile	MPU

## 3010 Series Epoxy Pedestal Pump



### SPECIFICATIONS

<b>MAX FLOW RATE</b>	5 GPM (19 LPM)
<b>PORTS</b>	0.6" (16mm) OD for hose connections
<b>BODY</b>	Phenolic
<b>SHAFT</b>	Stainless steel
<b>SEAL</b>	Lip seal
<b>BEARINGS</b>	PFTE/graphite
<b>BRACKET</b>	Plated steel
<b>IMPELLER</b>	Neoprene, nitrile, FKM
<b>WEIGHT</b>	0.6lb (0.25kg)

### MODELS

MODEL #	CE	VOLTAGE	IMPELLER	STYLE
3010-1011	Yes	N/A	Neoprene	Pedestal

## 12560 Series Phenolic Plastic Flex Pump



### FOR US MARKETS

Use where corrosion-resistant plastic material, self-priming, flow and debris tolerance are desired. Use neoprene for water and general-purpose pumping. A nitrile impeller is ideal for oil-based products. Use FKM for hydrocarbons and solvents. Motor is not explosion-proof. Do not run dry.

### SPECIFICATIONS

<b>VOLTAGE</b>	12V DC, CE approved
<b>MAX FLOW RATE</b>	4.6 GPM (17.4 LPM)
<b>MAX PRESSURE</b>	8.7 psi (20.1 bar), 20' of water
<b>SELF-PRIMING</b>	1-2' (0.3-0.6m) dry, 2-4' (0.6-1.2m) wet
<b>PORTS</b>	5/8" (16mm) hose barb
<b>MOTOR</b>	PMDC, TENV, thermal overload protected 7A nominal, 10A fuse
<b>BODY</b>	Phenolic
<b>LIQUID TEMPERATURE RANGE</b>	Neoprene - 45°F (7°C) to 160°F (70°C) Nitrile - 50°F (10°C) to 180°F (82°C)
<b>SHAFT</b>	Stainless steel
<b>SEAL</b>	Buna lip type
<b>APPROVALS</b>	Ignition protection
<b>IMPELLER</b>	Neoprene
<b>DIMENSIONS</b>	3-1/4" high x 5" long x 6-1/2" wide (82mm x 126mm x 164mm)
<b>WEIGHT</b>	4.5lb (2kg)

### MODELS

MODEL #	CE	VOLTAGE	IMPELLER	STYLE
12560-0001	Yes	12V DC	Neoprene	MPU

# 04 Flexible Impeller Pumps

EPOXY / PHENOLIC PLASTIC



## 12290 Series Phenolic Plastic Flex Pump



Use where corrosion-resistant phenolic or glass-filled epoxy material, self-priming and debris tolerance are desired. A nitrile impeller is ideal for oil-based products. Use neoprene for water and general-purpose pumping. Use FKM for hydrocarbons and solvents. Long-lasting AC induction motor has no brushes to wear out. Motor is not explosion-proof. Do not run dry.



### SPECIFICATIONS

<b>VOLTAGE</b>	60Hz - 115V AC, single phase, non-CE
<b>MAX FLOW RATE</b>	5.8 GPM (22 LPM)
<b>MAX PRESSURE</b>	17 psi (1.2 bar) 39' of water
<b>SELF-PRIMING</b>	Neoprene - 8-10' (2.4-3.1m) dry, 10-15' (3.1-4.6m) wet Nitrile/FKM - 3-5' (0.9-1.5m) dry, 8-10' (2.4-3.1m) wet
<b>PORTS</b>	5/8" (16mm) hose barb
<b>MOTOR</b>	1/6 HP ODP, 1/4 HP, TENV 6' (2m) power cord with 2-prong grounded plug Thermal overload protected 4.2A full load OD, 3.3A full load TENV
<b>BODY</b>	Phenolic
<b>LIQUID TEMPERATURE RANGE</b>	Neoprene - 45°F (7°C) to 180°F (82°C) Nitrile - 50°F (10°C) to 180°F (82°C) FKM - 60°F (16°C) to 180°F (82°C)
<b>SHAFT</b>	Stainless steel
<b>SEAL</b>	Buna or FKM lip type
<b>IMPELLER</b>	Neoprene, nitrile, FKM
<b>DIMENSIONS</b>	8-3/8" high x 9.7" long x 14.3" wide (211mm x 245mm x 361mm)
<b>WEIGHT</b>	12lb (5.5kg)

### MODELS

MODEL #	CE	VOLTAGE	IMPELLER	STYLE
12290-0001	No	115V AC	Neoprene	MPU
12290-0003	No	115V AC	Nitrile	MPU
12290-0004	No	115V AC	FKM	MPU
12290-0271	No	115V AC	Neoprene	MPU
12290-0273	No	115V AC	Nitrile	MPU
12290-0274	No	115V AC	FKM	MPU

## 17430 Series Epoxy Utility Pump



Use where corrosion-resistant phenolic or glass-filled epoxy material, self-priming and debris tolerance are desired. A nitrile impeller is ideal for oil-based products. Use neoprene for water and general-purpose pumping. Use FKM for hydrocarbons and solvents. Long-lasting AC induction motor has no brushes to wear out. Motor is not explosion-proof. Do not run dry.



### SPECIFICATIONS

<b>VOLTAGE</b>	60Hz - 115V AC, single phase, non-CE
<b>MAX FLOW RATE</b>	11 GPM (42 LPM)
<b>MAX PRESSURE</b>	21 psi (1.5 bar) or 50' (15.2m) of head
<b>SELF-PRIMING</b>	12-15' (3.7-4.6m) dry, 18-22' (5.5-6.7m) wet
<b>PORTS</b>	1/2" (13mm) NPTF
<b>MOTOR</b>	1/2 HP TEFC, AC induction type 6' (1.8m) power cord with 3-prong grounded plug Thermal overload protected 8.8A full load
<b>BODY</b>	Epoxy
<b>LIQUID TEMPERATURE RANGE</b>	Neoprene - 45°F (7°C) to 180°F (82°C) Nitrile - 50°F (10°C) to 180°F (82°C) FKM - 60°F (16°C) to 180°F (82°C)
<b>SHAFT</b>	Epoxy sleeve
<b>SEAL</b>	Mechanical carbon-on-ceramic
<b>IMPELLER</b>	Nitrile, FKM
<b>DIMENSIONS</b>	8-3/8" high x 9.7" long x 14.3" wide (211mm x 245mm x 361mm)
<b>WEIGHT</b>	33.5lb (15.2kg)

### MODELS

MODEL #	CE	VOLTAGE	IMPELLER	STYLE
17430-0003	No	115V AC	Nitrile	MPU

# 04 Flexible Impeller Pumps

EPOXY / PHENOLIC PLASTIC



## 28250 Series Pedestal Pump & 28260 Series Epoxy Head Kit Pump



### FEATURES

- Self-priming from dry up to 16.4' (5m)
- Flows up to 18.5 GPM (70 LPM)
- Pressure up to 43.5 psi (3 bar)
- Handles hard or soft solids - 0.2" (5mm) maximum diameter
- High-chemical-resistance epoxy plastic
- Non-pulsating flow, proportional to speed
- Handles viscosities up to 10,000 cP
- No metal parts in liquid contact
- Fits IEC standard motor B3/B14, frame 80 (model 28260)

### SPECIFICATIONS

<b>MAX PRESSURE</b>	Standard - 36 psi (2.5 bar) High - 43.5 psi (3 bar)
<b>PORTS</b>	3/4" BSP external thread to BS21 DIN2999
<b>PUMP HEAD</b>	Epoxy thermoset plastic
<b>SHAFT</b>	Epoxy-covered stainless steel, shaft extension
<b>SEAL</b>	Carbon/ceramic mechanical face seal Nitrile elastomer Optional tungsten carbide/ceramic hard-faced mechanical seal
<b>BEARINGS</b>	Model 28250 - twin single row, ball type with epoxy-coated, cast iron housing Model 28260 - uses motor bearings with epoxy-coated, cast iron motor adapter
<b>END COVER</b>	Epoxy thermoset plastic
<b>IMPELLER</b>	Neoprene, EPDM, nitrile, FKM,
<b>WEIGHT</b>	3.7lb (1.7kg)

Pressures over 24.7 psi (1.7 bar) may reduce motor shaft lift.



## 28350 Series Pedestal Pump & 28360 Series Epoxy Head Kit Pump



### FEATURES

- Self-priming from dry up to 16.4' (5m)
- Flows up to 42.3 GPM (160 LPM)
- Pressure up to 36.25 psi (2.5 bar)
- Handles hard or soft solids - 0.2" (5mm) maximum diameter
- Tolerates abrasive wear; replaceable wearplate
- Non-pulsating flow, proportional to speed
- Handles viscosities up to 4,000 cP
- Minimal shear to thixotropic fluids
- Fits IEC standard motor B3/B14, frame 80 (model 28360)

### SPECIFICATIONS

<b>MAX PRESSURE</b>	Standard - 36 psi (2.5 bar)
<b>PORTS</b>	1" (25mm) BSP external thread to BS21 DIN2999
<b>PUMP HEAD</b>	Epoxy
<b>SHAFT</b>	Model 28350 - epoxy-covered stainless steel Model 28360 - epoxy-coated stainless steel, shaft extension
<b>SEAL</b>	Carbon/ceramic mechanical face seal, nitrile elastomer
<b>BEARINGS</b>	Model 28350 - twin single row, ball type with epoxy-coated, cast iron housing Model 28360 - uses motor bearings with epoxy-coated, cast iron motor adapter
<b>END COVER</b>	Epoxy
<b>IMPELLER</b>	Neoprene, EPDM, nitrile and FKM elastomers
<b>WEIGHT</b>	4.6lb (2.1kg)

### MODELS

MODEL #	CE	VOLTAGE	IMPELLER	STYLE
28350-2101	Yes	N/A	Neoprene	Pedestal
28350-2103	Yes	N/A	Nitrile	Pedestal
28350-2104	Yes	N/A	FKM	Pedestal
28350-2123	Yes	N/A	Nitrile	Pedestal
28350-2124	Yes	N/A	FKM	Pedestal
28350-2125	Yes	N/A	Sanitary neoprene	Pedestal
28360-2101	Yes	N/A	Nitrile	Head kit
28360-2103	Yes	N/A	FKM	Head kit
28360-2104	Yes	N/A	FKM	Head kit
28360-2204	Yes	N/A	Nitrile	Head kit



# 04 Flexible Impeller Pumps

EPOXY / PHENOLIC PLASTIC



## 30510 Series Epoxy Plastic Pedestal & Close-Coupled Flex Pump



Use where single or variable speed operation and plastic-epoxy material is desirable. Self-priming, 8 GPM (30 LPM) flow and debris-tolerant. A nitrile impeller is ideal for oil-based products. Use neoprene for water and general-purpose pumping. Use FKM for hydrocarbons and most solvents. Optional EPDM standard and high-pressure impeller kits (7614-0002) and (8980-0002) for hygienic applications and some ketone solvents. Use a tungsten carbide seal when pumping highly-corrosive or abrasive fluids. Motor is not explosion-proof. Do not run dry.

For pump head-only models (30510-3xxx), select NEMA 56 C-frame C-face motor rated at 3/4 HP at 1750 rpm with appropriate service factor. Motor must handle high-axial loads. Ball bearings locked against axial movement are recommended. Motor must deliver 1.5ft-lbs and 4.3ft-lbs torque minimum in forward and reverse directions respectively. Use only capacitor start motors.

For pedestal mount models (30510-1xxx) operating at 1750 rpm, select a 3/4 HP or 1-1/2 HP motor for standard or high-pressure impellers respectively, with an appropriate service factor. For high-pressure impellers, the motor must supply 3ft-lbs or 6.9ft-lbs of torque minimum for forward and reverse operation respectively.

Rated flow is based on neoprene impeller pumping water. Reduce rated flow 10 percent for nitrile, FKM, and EPDM standard impellers. Reduce rated flow 15 percent for nitrile, FKM and EPDM high-pressure impellers.

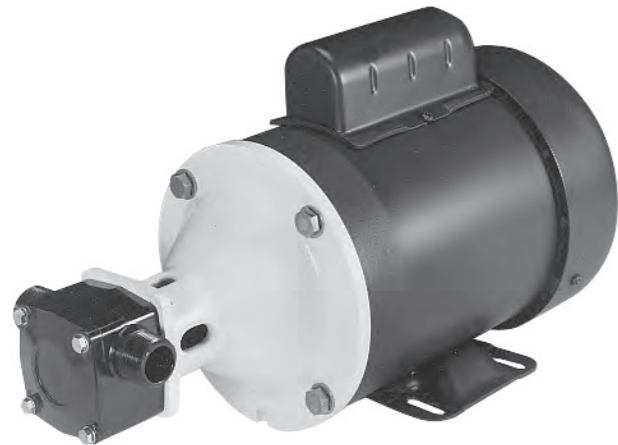

### SPECIFICATIONS

<b>VOLTAGE</b>	60Hz - 115V AC, single phase, non-CE
<b>MAX FLOW RATE</b>	8 GPM (30 LPM)
<b>MAX PRESSURE</b>	Consult performance chart
<b>SELF-PRIMING</b>	Neoprene/nitrile/FKM - 7-10' (2.1-3m) dry, 17-22' (5.7-6.7m) wet EPDM - 4-6' (1.2-1.8m) dry, 10-12' (3.1-3.7m) wet
<b>PORTS</b>	3/4" (19mm) NPTM
<b>MOTOR</b>	3/4 HP, TEFC AC induction type Intermittent duty, 56 C-frame, C-face 3-prong grounded plug Thermal overload protected
<b>BODY</b>	Epoxy plastic
<b>LIQUID TEMPERATURE RANGE</b>	Neoprene - 45°F (7°C) to 180°F (82°C) Nitrile - 50°F (10°C) to 180°F (82°C) FKM - 60°F (16°C) to 180°F (82°C) EPDM - 45°F (7°C) to 185°F (85°C)
<b>SHAFT</b>	Epoxy plastic sleeve
<b>SEAL</b>	Mechanical carbon or tungsten carbide on ceramic
<b>IMPELLER</b>	Neoprene, nitrile, FKM, EPDM
<b>DIMENSIONS</b>	Consult data sheet 43000-0516
<b>WEIGHT</b>	Model 30510-5xxx - 35lb (15.9kg) Model 30510-3xxx - 6.5lb (3kg) Model 30510-1xxx - 4.5lb (2kg)

## 30520 Series Epoxy Plastic Pedestal & Close-Coupled Flex Pump



Use where single or variable speed operation and plastic-epoxy material is desirable. Self-priming, 22 GPM (83 LPM) flow and debris-tolerant. A nitrile impeller is ideal for oil-based products. Use neoprene for water and general-purpose pumping. Use FKM for hydrocarbons and most solvents. Optional EPDM standard and high-pressure impeller kits (8981-0002) and (8840-0002) for hygienic applications and some ketone solvents. Use a tungsten carbide seal when pumping highly-corrosive or abrasive fluids. Motor is not explosion-proof. Do not run dry.

For pump head-only models (30520-3xxx), select NEMA 145 TC-frame C-face motor rated at 1-1/2 HP at 1750 rpm with appropriate service factor. Motor must handle high-axial loads. Front ball bearing locked against axial movement is recommended. Motor must deliver 4.8ft-lbs and 11.2ft-lbs torque minimum in forward and reverse directions, respectively. Use only capacitor start motors.

For pedestal mount models (30520-1xxx) operating at 1750 rpm, select a 1-1/2 HP or 3 HP motor for standard or high-pressure impellers respectively, with an appropriate service factor. For high-pressure impellers, the motor must supply 7.9ft-lbs or 16.3ft-lbs of torque minimum for forward and reverse operation respectively.

Rated flow is based on neoprene impeller pumping water. Reduce rated flow 10 percent for nitrile, FKM, and EPDM standard impellers. Reduce rated flow 15 percent for nitrile, FKM and EPDM high-pressure impellers.



### SPECIFICATIONS

<b>VOLTAGE</b>	60Hz - 115V and 230V AC, single phase, non-CE
<b>MAX FLOW RATE</b>	22 GPM (83 LPM)
<b>MAX PRESSURE</b>	Standard - 30 psi (2.1 bar) or 70' (21.3m) of head High - 60 psi (4.2 bar) or 138' (42.1m) of head
<b>SELF-PRIMING</b>	Neoprene/nitrile/FKM - 7-10' (2.1-3m) dry, 17-22' (5.7-6.7m) wet EPDM - 4-6' (1.2-1.8m) dry, 10-12' (3.1-3.7m) wet
<b>PORTS</b>	1" (25mm) NPTM
<b>MOTOR</b>	1-1/2 HP, capacity start, TEFC, C-face, H14 TC-frame 6' (1.8m) power cord with 3-prong grounded plug Thermal overload protected
<b>BODY</b>	Epoxy plastic
<b>LIQUID TEMPERATURE RANGE</b>	Neoprene - 45°F (7°C) to 180°F (82°C) Nitrile - 50°F (10°C) to 180°F (82°C) FKM - 60°F (16°C) to 180°F (82°C) EPDM - 45°F (7°C) to 185°F (85°C)
<b>SHAFT</b>	Epoxy plastic sleeve
<b>SEAL</b>	Mechanical carbon or tungsten carbide on ceramic
<b>IMPELLER</b>	Neoprene, nitrile, FKM, optional EPDM
<b>DIMENSIONS</b>	Pump and motor - 9.1" high x 8.9" long x 16.25" wide (230mm x 224mm x 410mm) Pump head - 6.6" high x 6.6" long x 6.8" wide (167mm x 167mm x 171mm) Pedestal mount - 4.75" high x 4.9" long x 9.6" wide (120mm x 123mm x 243mm)
<b>WEIGHT</b>	Pump and motor - 54.5lb (24.7kg) Pump head - 10.5lb (4.8kg) Pedestal mount - 7lb (3.2kg)

# 04 Flexible Impeller Pumps

BRONZE



## 17830 Reversible DC Water Puppy



### MODELS

MODEL #	CE	VOLTAGE	IMPELLER	STYLE
17830-0012	No	12V DC	Nitrile	MPU
17830-0024	No	24V DC	Nitrile	MPU

### FOR INTERNATIONAL MARKETS

Especially suited for viscous fluids and engine oil transfer where self-priming and 3 GPM (11.4 LPM) flow is required. Pump oil from crankcase to storage container, and from storage container to waste container automatically using the manual flow reverse switch. No need to remove or reattach hoses to reverse oil flow direction. Oil temperature should be 100°F (38°C) to 140°F (60°C). Use 12V DC from vehicle battery. Do not run dry.

### SPECIFICATIONS

<b>VOLTAGE</b>	12V DC
<b>MAX FLOW RATE</b>	3 GPM (11.4 LPM)
<b>MAX PRESSURE</b>	8.7 psi (0.6 bar) or 20' (6.1m) of lift
<b>SELF-PRIMING</b>	3-4' (1-1.2m) dry, 15-20' (4.6-6.1m) wet
<b>PORTS</b>	3/8" (10mm) NPTF
<b>MOTOR</b>	PMDC, TENV with manual reverse switch 10A nominal, 15A fuse
<b>BODY</b>	Bronze
<b>LIQUID TEMPERATURE RANGE</b>	Nitrile - 45°F (7°C) to 180°F (82°C)
<b>SHAFT</b>	Stainless steel
<b>SEAL</b>	Buna lip type
<b>CERTIFICATIONS</b>	CE
<b>IMPELLER</b>	Nitrile
<b>DIMENSIONS</b>	4.4" high x 3.25" long x 7.9" wide (113mm x 83mm x 200mm)
<b>WEIGHT</b>	9lb (4.1kg)

## 18660 DC Water Puppy



### MODELS

MODEL #	CE	VOLTAGE	IMPELLER	STYLE
18660-0121	No	12V DC	Neoprene	MPU
18660-0123	No	12V DC	Nitrile	MPU

For general transfer pumping where self-priming, 6.3 GPM (24 LPM) flow, and debris tolerance are required. Use optional oil-resistant nitrile impeller 6303-0003 if oil or diesel fuel are present. Do not run dry.

### SPECIFICATIONS

<b>VOLTAGE</b>	12V DC, non-CE
<b>MAX FLOW RATE</b>	6.3 GPM (24 LPM)
<b>MAX PRESSURE</b>	8.7 psi (0.6 bar) or 20' (6.1m) of lift
<b>SELF-PRIMING</b>	2-4' (0.6-1.2m) dry, 15-20' (4.6-6.1m) wet
<b>PORTS</b>	1.2" (13mm) NPTF, 3/4" (19mm) male garden hose adapter
<b>MOTOR</b>	PMDC, TENV 8A nominal, 15A fuse
<b>BODY</b>	Bronze
<b>LIQUID TEMPERATURE RANGE</b>	Neoprene - 45°F (7°C) to 180°F (82°C)
<b>SHAFT</b>	Stainless steel
<b>SEAL</b>	Nitrile lip type
<b>IMPELLER</b>	Neoprene or nitrile
<b>DIMENSIONS</b>	3.4" high x 4.75" long x 6.5" wide (86mm x 121mm x 165mm)
<b>WEIGHT</b>	4.5lb (2kg)

## 18670 Commercial Duty DC Water Puppy



### MODELS

MODEL #	CE	VOLTAGE	IMPELLER	STYLE
18670-0123	No	12V DC	Nitrile	MPU
18670-0943	No	24V DC	Nitrile	MPU

The Commercial Duty Water Puppy has 25 percent more flow than the standard model and a heavy-duty PMDC motor. For general transfer pumping where self-priming, 8 GPM (30.4 LPM) flow and debris tolerance are required. Oil-resistant nitrile impeller is standard. Do not run dry.

### SPECIFICATIONS

<b>VOLTAGE</b>	12V or 24V DC, non-CE
<b>MAX FLOW RATE</b>	8 GPM (30.4 LPM)
<b>MAX PRESSURE</b>	8.7 psi (0.6 bar) or 20' (6.1m) of lift
<b>SELF-PRIMING</b>	4-6' (1.2-1.8m) dry, 15-20' (4.6-6.1m) wet
<b>PORTS</b>	1.2" (13mm) NPTF and 1" (25mm) hose barb, 3/4" (19mm) male garden hose adapter
<b>MOTOR</b>	PMDC, TENV AMP draw 11.5A at 12V with 20A fuse, 5A at 24V with 10A fuse
<b>BODY</b>	Bronze
<b>LIQUID TEMPERATURE RANGE</b>	Nitrile - 50°F (10°C) to 180°F (82°C)
<b>SHAFT</b>	Stainless steel 316
<b>SEAL</b>	Lip type
<b>IMPELLER</b>	Nitrile
<b>DIMENSIONS</b>	3" high x 4.75" long x 6.9" wide (76mm x 120mm x 175mm)
<b>WEIGHT</b>	6lb (2.7kg)

# 04 Flexible Impeller Pumps

BRONZE



## 23610 Maxi Puppy 3000



Continuously rated, heavy-duty pumps for general-purpose use.

### FEATURES

- Simple design means fewer wearing parts
- 11.6 GPM (44 LPM) output at 10' (3m) head
- Self-priming to 8' (2.4m)

### MODELS

MODEL #	CE	VOLTAGE	IMPELLER	STYLE
23610-3003	Yes	12V DC	Nitrile	MPU
23610-3103	Yes	24V DC	Nitrile	MPU

## 23620 Mini Puppy



Continuously rated, medium-duty pumps for general-purpose use.

### FEATURES

- Simple design means fewer wearing parts
- 1.6 GPM (6 LPM) output at 10' (3m) head
- Self-priming to 5' (1.5m)

### MODELS

MODEL #	CE	VOLTAGE	IMPELLER	STYLE
23620-4003	Yes	12V DC	Nitrile	MPU
23620-4103	Yes	24V DC	Nitrile	MPU

## 23670 Junior Puppy



Continuously rated, medium-duty pumps for general-purpose use.

### FEATURES

- Presence of small debris is no problem to these bronze-bodied, flexible impeller pumps
- Simple design means fewer wearing parts
- 4.1 GPM (15.5 LPM) output at 16' (5m) of head
- Self-priming up to 8' (2.5m)

### MODELS

MODEL #	CE	VOLTAGE	IMPELLER	STYLE
23670-4003	Yes	12V DC	Nitrile	MPU
23670-4103	Yes	24V DC	Nitrile	MPU

## 23920 Extended Run Dry Utility Puppy 2000/3000



Continuously rated, medium-duty pumps for general-purpose use.

### SPECIFICATIONS

<b>VOLTAGE</b>	12V DC, CE-approved
<b>MAX FLOW RATE</b>	2000 - 8 GPM (30 LPM) 3000 - 11 GPM (42 LPM)
<b>MAX PRESSURE</b>	8 psi (0.55 bar) or 19' (5.8m) of lift
<b>SELF-PRIMING</b>	Model 2000 - 3-4' (0.9-1.2m) dry Model 3000 - 6-8' (1.8-2.4m) dry
<b>PORTS</b>	3/4" (19mm) NPTF or BSP
<b>MOTOR</b>	Permanent magnet DC 12/24V
<b>BODY</b>	Bronze
<b>LIQUID TEMPERATURE RANGE</b>	45°F (7°C) to 180°F (82°C)
<b>SHAFT</b>	Stainless steel
<b>SEAL</b>	Model 2000 - lip seal, nitrile Model 3000 - mechanical seal, carbon, ceramic, nitrile
<b>IMPELLER</b>	Nitrile
<b>DIMENSIONS</b>	Model 2000 - 4.3" high x 7" long x 4.9" wide (110mm x 121mm x 124mm) Model 3000 - 4.3" high x 8.5" long x 4.9" wide (110mm x 179mm x 124mm)
<b>WEIGHT</b>	Model 2000 - 8.2lb (4kg) Model 3000 - 9.7lb (3.4kg)

### MODEL 2000

MODEL #	CE	VOLTAGE	IMPELLER	STYLE
23920-2423	Yes	12V DC	Nitrile	BSP
23920-2523	Yes	24V DC	Nitrile	BSP
23920-9423	Yes	12V DC	Nitrile	NPT
23920-9523	Yes	24V DC	Nitrile	NPT

### MODEL 3000

MODEL #	CE	VOLTAGE	IMPELLER	STYLE
23920-2223	Yes	12V DC	Nitrile	BSP
23920-2323	Yes	24V DC	Nitrile	BSP
23920-9223	Yes	12V DC	Nitrile	NPT
23920-9323	Yes	24V DC	Nitrile	NPT



# 04 Flexible Impeller Pumps

BRONZE



## 18610 Bronze Utility Pump



For general transfer pumping where self-priming, 6 GPM (22.8 LPM) flow, debris tolerance and portable 115V AC operation is desired. Choice of impeller materials. Use nitrile for oil-based products. Use FKM for hydrocarbons and solvents. Use neoprene for water and general-purpose pumping. Long-lasting AC induction motor has no brushes to wear out. Do not pump gasoline or other flammable liquids. Do not run dry. Motor is not explosion-proof. For continuous operation at 75°F (24°C), do not exceed 15 psi (1 bar) outlet pressure or 38' (11.6m) of lift.

### SPECIFICATIONS

<b>VOLTAGE</b>	60Hz - 115V AC, single phase, non-CE
<b>MAX FLOW RATE</b>	6 GPM (22.8 LPM)
<b>MAX PRESSURE</b>	ODF - 13 psi (0.9 bar) or 30' (9.1m) of head TENV - 17 psi (1.2 bar) or 39' (12m) of head
<b>SELF-PRIMING</b>	4-6' (1.2-1.8m) dry, 16-20' (4.9-6.1m) wet
<b>PORTS</b>	1/2" (13mm) NPTF, 3/4" (19mm) male garden hose adapter
<b>MOTOR</b>	1/4 HP, non-vented 8' (2.4m) power cord with 3-prong grounded plug Thermal overload protection
<b>BODY</b>	Bronze
<b>LIQUID TEMPERATURE RANGE</b>	Neoprene - 45°F (7°C) to 180°F (82°C) Nitrile - 50°F (10°C) to 180°F (82°C) FKM - 60°F (15°C) to 180°F (82°C)
<b>SHAFT</b>	Stainless steel 316
<b>SEAL</b>	Neoprene lip type
<b>IMPELLER</b>	Neoprene
<b>DIMENSIONS</b>	9" high x 7" long x 7-1/4" wide (229mm x 178mm x 184mm)
<b>WEIGHT</b>	12lb (5.5kg)

### MODELS

See page 128 for model numbers.

## 11810 Bronze AC Utility Pump



For general transfer pumping where self-priming, 10 GPM (38 LPM) flow, debris tolerance and portable 115V AC operation is desired. Use nitrile for oil-based products. Use neoprene for water and general-purpose pumping. Do not run dry. Motor is not explosion-proof.

### SPECIFICATIONS

<b>VOLTAGE</b>	60Hz - 115V AC, single phase, non-CE
<b>MAX FLOW RATE</b>	10 GPM (38 LPM)
<b>MAX PRESSURE</b>	17 psi (1.2 bar) or 39' (12m) of head
<b>SELF-PRIMING</b>	8-10' (2.4-3m) dry, 16-20' (4.9-6.1m) wet
<b>PORTS</b>	1/2" (13mm) NPTF and 3/4" (19mm) male garden hose thread
<b>MOTOR</b>	1/3 HP, TEFC or ODP AC induction type 8' (2.4m) power cord with 3-prong grounded plug Thermal overload protection 7A nominal, 10A fuse
<b>BODY</b>	Bronze
<b>LIQUID TEMPERATURE RANGE</b>	Neoprene - 45°F (7°C) to 180°F (82°C) Nitrile - 50°F (10°C) to 180°F (82°C)
<b>SHAFT</b>	Stainless steel 316
<b>SEAL</b>	Nitrile lip type
<b>IMPELLER</b>	Nitrile
<b>DIMENSIONS</b>	7-3/4" high x 7-1/4" long x 10-1/2" wide (197mm x 184mm x 267mm)
<b>WEIGHT</b>	ODP - 20lb (9.1kg) TEFC - 25lb (11.3kg)

# 04 Flexible Impeller Pumps

BRONZE



## 6050 Bronze AC Utility Pump



For general transfer pumping using 115V AC power where self-priming, 23 GPM (87 LPM) flow and debris tolerance are required. Oil-resistant nitrile impeller is standard. Do not run dry.

### SPECIFICATIONS

<b>VOLTAGE</b>	60Hz - 115V and 230V AC, single phase, non-CE
<b>MAX FLOW RATE</b>	23 GPM (87 LPM)
<b>MAX PRESSURE</b>	26 psi (1.8 bar) or 60' (18.2m) of lift
<b>SELF-PRIMING</b>	8-10' (2.4-3m) dry, 20-22' (6.1-6.7m) wet
<b>PORTS</b>	1" (25mm) NPTF
<b>MOTOR</b>	3/4 HP TEFC or ODP AC induction type 8' (2.4m) power cord with 3-prong grounded plug Thermal overload protection
<b>BODY</b>	Bronze
<b>LIQUID TEMPERATURE RANGE</b>	50°F (10°C) to 180°F (82°C)
<b>SHAFT</b>	Stainless steel 316
<b>SEAL</b>	Nitrile lip type
<b>IMPELLER</b>	Nitrile
<b>DIMENSIONS</b>	8.6" high x 7-3/4" long x 13" wide (218mm x 197mm x 331mm)
<b>WEIGHT</b>	35.5lb (16.1kg)

### MODELS

MODEL #	CE	VOLTAGE	IMPELLER	STYLE
6050-0003	No	115V AC	Nitrile	MPU/ODP
6050-0013	No	115V AC	Nitrile	MPU/TEFC



## 50005 Series



### FEATURES

- Self-priming from dry up to 4.9' (1.5m)
- Flows up to 0.3 GPM (4.5 LPM)
- Pressure up to 29 psi (2 bar)
- Handles hard or soft solids
- Tolerates abrasive wear
- Non-pulsating flow
- Handles viscosities up to 500 cP
- Uses standard IEC motor

### SPECIFICATIONS

<b>PORTS</b>	3/8" BSP internal thread, 1" (25mm) bore hose connection
<b>PUMP HEAD</b>	Bronze
<b>SHAFT</b>	Stainless steel, shaft extension
<b>SEAL</b>	Nitrile lip seal
<b>BEARINGS</b>	Uses motor bearings with polypropylene motor adapter
<b>END COVER</b>	Brass
<b>WEIGHT</b>	13.7lb (6.2kg)

### MODELS

MODEL #	CE	VOLTAGE	IMPELLER	STYLE
50005-8411	Yes	230V, 1Ph, 50Hz	Neoprene	MPU
50005-8413	Yes	230V, 1Ph, 50Hz	Nitrile	MPU



## 50010 Series



### FEATURES

- Self-priming from dry up to 4.9' (1.5m)
- Flows up to 1.6 GPM (6 LPM)
- Pressure up to 36.2 psi (2.5 bar)
- Will handle hard or soft solids
- Will tolerate abrasive wear
- Non-pulsating flow
- Will handle viscosities up to 500 cP
- Uses standard IEC motor

### SPECIFICATIONS

<b>PORTS</b>	3/8" BSP internal thread and 3/4" (19mm) bore hose connections
<b>PUMP HEAD</b>	Bronze
<b>SHAFT</b>	Stainless steel, shaft extension
<b>SEAL</b>	Nitrile lip seal
<b>BEARINGS</b>	Uses motor bearings with polypropylene motor adapter
<b>END COVER</b>	Brass
<b>WEIGHT</b>	13.9lb (6.3kg)



### MODELS

MODEL #	CE	VOLTAGE	IMPELLER	STYLE
50010-2411	Yes	230V, 1Ph, 50Hz	Neoprene	MPU
50010-2413	Yes	230V, 1Ph, 50Hz	Nitrile	MPU

## 50020 Series



### FEATURES

- Self-priming from dry up to 4.9' (1.5m)
- Flows up to 4.8 GPM (18 LPM)
- Pressure up to 24.7 psi (1.7 bar)
- Will handle hard or soft solids
- Will tolerate abrasive wear
- Non-pulsating flow
- Will handle viscosities up to 500 cP
- Uses standard IEC motor

### SPECIFICATIONS

<b>PORTS</b>	1/2" (13mm) BSP internal thread and 1" (25mm) bore hose connections
<b>PUMP HEAD</b>	Bronze
<b>SHAFT</b>	Stainless steel, shaft extension
<b>SEAL</b>	Nitrile lip seal
<b>BEARINGS</b>	Uses motor bearings with polypropylene motor adapter
<b>END COVER</b>	Brass
<b>WEIGHT</b>	14.1lb (6.4kg)



### MODELS

MODEL #	CE	VOLTAGE	IMPELLER	STYLE
50020-2411	Yes	230V, 1Ph, 50Hz	Neoprene	MPU
50020-2413	Yes	230V, 1Ph, 50Hz	Nitrile	MPU

# 04 Flexible Impeller Pumps

BRONZE

## 53010 Series



### FEATURES

- Self-primers from dry up to 4.9' (1.5m)
- Flows up to 3 GPM (12 LPM) at 50.8 psi (3.5 bar)
- Pressure up to 24.7 psi (1.7 bar)
- Handles hard or soft solids
- Tolerates abrasive wear
- Non-pulsating flow
- Handles viscosities up to 500 cP
- Uses standard IEC motor
- Dry-running capability for 30 minutes without damage to pump (post operation)

### SPECIFICATIONS

<b>PORTS</b>	1/2" (13mm) BSP external thread
<b>PUMP HEAD</b>	Bronze with integral fluid reservoir to protect pump against dry running for up to 30 minutes (post operation)
<b>SHAFT</b>	Stainless steel, shaft extension
<b>SEAL</b>	Carbon/ceramic mechanical face seal, butyl elastomers
<b>BEARINGS</b>	Uses motor bearings with polypropylene motor adapter
<b>END COVER</b>	Brass
<b>WEIGHT</b>	15.7lb (7.1kg)

### MODELS

MODEL #	CE	VOLTAGE	IMPELLER	STYLE
53010-2111	Yes	230V, 1Ph, 50Hz	Neoprene	MPU
53010-2113	Yes	230V, 1Ph, 50Hz	Nitrile	MPU
53010-2115	Yes	230V, 1Ph, 50Hz	Sanitary neoprene	MPU

## 53020 Series



### FEATURES

- Self-primers from dry up to 4.9' (1.5m)
- Flows up to 4.5 GPM (18 LPM)
- Pressure up to 24.7 psi (1.7 bar)
- Handles hard or soft solids
- Tolerates abrasive wear
- Non-pulsating flow
- Handles viscosities up to 500 cP
- Uses standard IEC motor
- Dry-running capability for 30 minutes without damage to pump (post operation)

### SPECIFICATIONS

<b>PORTS</b>	3/4" (19mm) BSP internal thread
<b>PUMP HEAD</b>	Bronze with integral fluid reservoir to protect pump against dry running for up to 30 minutes (post operation)
<b>SHAFT</b>	Stainless steel, shaft extension
<b>SEAL</b>	Carbon/ceramic mechanical face seal, butyl elastomers
<b>BEARINGS</b>	Uses motor bearings with polypropylene motor adapter
<b>END COVER</b>	Brass
<b>WEIGHT</b>	15.7lb (7.1kg)

### MODELS

MODEL #	CE	VOLTAGE	IMPELLER	STYLE
53020-2011	Yes	230V, 1Ph, 50Hz	Neoprene	MPU
53020-2013	Yes	230V, 1Ph, 50Hz	Nitrile	MPU

## 53040 Series



### FEATURES

- Self-primers from dry up to 9.8' (3m)
- Flows up to 9.2 GPM (35 LPM)
- Pressure up to 36.3 psi (2.5 bar)
- Handles hard or soft solids
- Tolerates abrasive wear
- Non-pulsating flow
- Handles viscosities up to 500 cP
- Uses standard IEC motor
- Dry-running capability for 30 minutes without damage to pump (post operation)

### SPECIFICATIONS

<b>PORTS</b>	1" (25mm) BSP internal thread
<b>PUMP HEAD</b>	Bronze with integral fluid reservoir to protect pump against dry running for up to 30 minutes (post operation)
<b>SHAFT</b>	Stainless steel, shaft extension
<b>SEAL</b>	Carbon/ceramic mechanical face seal, butyl elastomers
<b>BEARINGS</b>	Uses motor bearings with polypropylene motor adapter
<b>END COVER</b>	Brass
<b>WEIGHT</b>	21lb (9.5kg)

### MODELS

MODEL #	CE	VOLTAGE	IMPELLER	STYLE
53040-2001	Yes	230V, 1Ph, 50Hz	Neoprene	MPU
53040-2003	Yes	230V, 1Ph, 50Hz	Nitrile	MPU
53040-2021	Yes	230V, 1Ph, 50Hz	Neoprene	MPU
53040-2103	Yes	110V, 1Ph, 50Hz	Neoprene	MPU

## 53080 Series



### FEATURES

- Self-primers from dry up to 9.8' (3m)
- Flows up to 21 GPM (80 LPM)
- Pressure up to 29 psi (2 bar)
- Handles hard or soft solids
- Tolerates abrasive wear
- Non-pulsating flow
- Handles viscosities up to 500 cP
- Uses standard IEC motor
- Dry-running capability for 30 minutes without damage to pump (post operation)

### SPECIFICATIONS

<b>PORTS</b>	1-1/2" (38mm) BSP internal thread
<b>PUMP HEAD</b>	Bronze with integral fluid reservoir to protect pump against dry running for up to 30 minutes (post operation)
<b>SHAFT</b>	Stainless steel, shaft extension
<b>SEAL</b>	Carbon/ceramic mechanical face seal, nitrile elastomers
<b>BEARINGS</b>	Uses motor bearings with polypropylene motor adapter
<b>CABLE</b>	Fitted with 6.6' (2m) long supply cable
<b>WEIGHT</b>	33.7lb (15kg)

### MODELS

MODEL #	CE	VOLTAGE	IMPELLER	STYLE
53080-2001	Yes	230V, 1Ph, 50Hz	Neoprene	MPU
53080-2003	Yes	230V, 1Ph, 50Hz	Nitrile	MPU
53080-2063	Yes	220V, 50Hz	Nitrile	MPU

# 04 Flexible Impeller Pumps

BRONZE



## 22860 Series



### FEATURES

- Flows up to 9.2 GPM (35 LPM) at 1500 rpm
- Self-primers from dry up to 9.8' (3m)
- Handles hard or soft solids
- Non-pulsating flow
- Gentle pump action does not damage shear-sensitive products
- Easy to service and maintain

### SPECIFICATIONS

<b>PORTS</b>	3/4" (19mm) BSP internal thread
<b>PUMP HEAD</b>	Bronze
<b>SHAFT</b>	Stainless steel, shaft extension
<b>SEAL</b>	Carbon/ceramic mechanical seal
<b>BEARINGS</b>	Uses motor bearings with epoxy-coated aluminum motor adapter, suitable for B3/B14 D80 frame motor to IEC 71 standard
<b>END COVER</b>	Brass
<b>WEIGHT</b>	4.2lb (1.9kg)

### MODELS

MODEL #	CE	VOLTAGE	IMPELLER	STYLE
22860-2001	Yes	N/A	Neoprene	Head kit
22860-2003	Yes	N/A	Nitrile	Head kit
22860-2021	Yes	N/A	Neoprene	Head kit, flange
22860-2061	Yes	N/A	Neoprene	Head kit
22860-2702	Yes	N/A	3A EPDM	Head kit

## 22870 Series

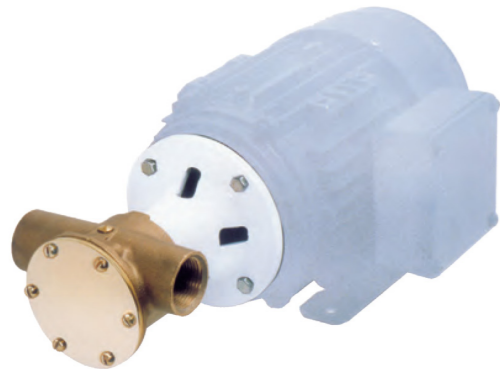

### FEATURES

- Flows up to 21 GPM (80 LPM) at 1500 rpm
- Self-primers from dry up to 16.4' (5m)
- Handles hard or soft solids
- Non-pulsating flow
- Gentle pump action does not damage shear-sensitive products
- Easy to service and maintain

### SPECIFICATIONS

<b>PORTS</b>	1" (25mm) BSP internal thread
<b>PUMP HEAD</b>	Bronze
<b>SHAFT</b>	Stainless steel 316, shaft extension
<b>SEAL</b>	Carbon/ceramic mechanical seal
<b>BEARINGS</b>	Uses motor bearings with epoxy-coated aluminum motor adapter, suitable for B3/B14 D80 frame motor to IEC 71 standard
<b>END COVER</b>	Brass
<b>WEIGHT</b>	5.7lb (2.6kg)

### MODELS

MODEL #	CE	VOLTAGE	IMPELLER	STYLE
22870-2001	Yes	N/A	Neoprene	Head kit
22870-2003	Yes	N/A	Nitrile	Head kit
22870-2043	Yes	N/A	Nitrile	Head kit
22870-2201	Yes	N/A	Neoprene	Head kit, no adapter
22870-2203	Yes	N/A	Nitrile	Head kit, no adapter
22870-2543	Yes	N/A	Nitrile	MPU
22870-2702	Yes	N/A	3A EPDM	Head kit

## 22880 Series

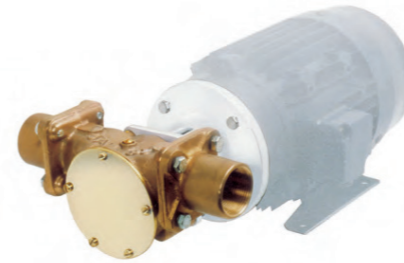

### FEATURES

- Flows up to 52.8 GPM (200 LPM) at 1500 rpm
- Self-primers from dry up to 9.8' (3m)
- Handles hard or soft solids
- Non-pulsating flow
- Gentle pump action does not damage shear-sensitive products
- Easy to service and maintain

### SPECIFICATIONS

<b>PORTS</b>	Flanged, adapters available
<b>PUMP HEAD</b>	Bronze
<b>SHAFT</b>	Stainless steel 316, shaft extension
<b>SEAL</b>	Carbon/ceramic mechanical seal
<b>BEARINGS</b>	Uses motor bearings with epoxy-coated aluminum motor adapter, suitable for B3/B14 D100 frame motor to IEC 71 standard
<b>END COVER</b>	Brass
<b>WEIGHT</b>	17lb (7.7kg)

### MODELS

MODEL #	CE	VOLTAGE	IMPELLER	STYLE
22880-0033	Yes	N/A	Nitrile	Head kit
22880-2201	Yes	N/A	Neoprene	Head kit, flange
22880-2203	Yes	N/A	Nitrile	Head kit, flange
22880-2401	Yes	N/A	Neoprene	Head kit, flange

## 22890 Series



### FEATURES

- Flows up to 71.3 GPM (270 LPM) at 1500 rpm
- Self-primers from dry up to 14.8' (4.5m)
- Handles hard or soft solids
- Non-pulsating flow
- Gentle pump action does not damage shear-sensitive products
- Easy to service and maintain

### SPECIFICATIONS

<b>PORTS</b>	Flanged, adapters available
<b>PUMP HEAD</b>	Bronze
<b>SHAFT</b>	Stainless steel 316, shaft extension
<b>SEAL</b>	Carbon/ceramic mechanical seal
<b>BEARINGS</b>	Uses motor bearings with epoxy-coated aluminum motor adapter, suitable for B3/B14 D100 frame motor to IEC 71 standard
<b>END COVER</b>	Brass
<b>WEIGHT</b>	20.5lb (9.3kg)

### MODELS

MODEL #	CE	VOLTAGE	IMPELLER	STYLE
22890-2001	Yes	N/A	Neoprene	Head kit

# 04 Flexible Impeller Pumps

BRONZE



## 53270 Series



### FEATURES

- Flows up to 71.3 GPM (270 LPM) at 1500 rpm
- Self-priming from dry up to 14.8' (4.5m)
- Handles hard or soft solids
- Non-pulsating flow
- Gentle pump action does not damage shear-sensitive products
- Easy to service and maintain

### SPECIFICATIONS

<b>PORTS</b>	2" (51mm) BSP internal thread
<b>PUMP HEAD</b>	Bronze
<b>SHAFT</b>	Stainless steel 316, shaft extension
<b>SEAL</b>	Carbon/ceramic mechanical seal
<b>BEARINGS</b>	Uses motor bearings with epoxy-coated aluminum motor adapter, suitable for B3/B14 D100 frame motor to IEC 71 standard
<b>END COVER</b>	Brass
<b>WEIGHT</b>	20.5lb (9.3kg)

### MODELS

See page 128 for model numbers

## 2760 Bronze Pedestal Pump



### SPECIFICATIONS

<b>MAX FLOW RATE</b>	4.4 GPM (20 LPM)
<b>MAX PRESSURE</b>	17 psi (1.2 bar) or 40' (12.2m) of head
<b>SELF-PRIMING</b>	8-10' (2.4-3m) dry, 15-22' (4.6-6.7m) wet
<b>PORTS</b>	1/4" (6mm) NPTF
<b>BODY</b>	Bronze
<b>LIQUID TEMPERATURE RANGE</b>	Neoprene - 45°F (7°C) to 180°F (82°C) Nitrile - 50°F (10°C) to 180°F (82°C)
<b>SHAFT</b>	Stainless steel, 3/8" (10mm) diameter
<b>SEAL</b>	Neoprene lip type
<b>IMPELLER</b>	Neoprene, nitrile
<b>DIMENSIONS</b>	2.4" high x 2.6" long x 3.6" wide (62mm x 67mm x 90mm)
<b>WEIGHT</b>	1.5lb (0.7kg)

## 2620 Bronze Pedestal Pump



### SPECIFICATIONS

<b>MAX FLOW RATE</b>	4.4 GPM (20 LPM)
<b>MAX PRESSURE</b>	13 psi (0.9 bar) or 30' (9.1m) of head
<b>SELF-PRIMING</b>	8-10' (2.4-3m) dry, 15-22' (4.6-6.7m) wet
<b>PORTS</b>	3/8" (10mm) NPTF
<b>BODY</b>	Bronze
<b>LIQUID TEMPERATURE RANGE</b>	Neoprene - 45°F (7°C) to 160°F (71°C) Nitrile - 50°F (10°C) to 160°F (71°C)
<b>SHAFT</b>	Bronze, 1/2" (13mm) diameter
<b>SEAL</b>	Neoprene lip type
<b>IMPELLER</b>	Neoprene, nitrile
<b>DIMENSIONS</b>	3.2" high x 3.1" long x 3.9" wide (81mm x 79mm x 100mm)
<b>WEIGHT</b>	2.7lb (1.3kg)

## 1673 Bronze Pedestal Flexible Impeller Pump



### SPECIFICATIONS

<b>MAX FLOW RATE</b>	8.9 GPM (40 LPM)
<b>MAX PRESSURE</b>	21 psi (1.5 bar) or 50' (15.2m) of head
<b>SELF-PRIMING</b>	8-10' (2.4-3m) dry, 15-20' (4.6-6.1m) wet
<b>PORTS</b>	1/2" (13mm) NPTF
<b>BODY</b>	Bronze
<b>LIQUID TEMPERATURE RANGE</b>	Neoprene - 45°F (7°C) to 160°F (71°C) Nitrile - 50°F (10°C) to 180°F (82°C)
<b>SHAFT</b>	Stainless steel, 5/8" (16mm) diameter
<b>SEAL</b>	Nitrile lip or face seal
<b>IMPELLER</b>	Neoprene, nitrile
<b>DIMENSIONS</b>	3.8" high x 4.1" long x 4-1/2" wide (96mm x 104mm x 113mm)
<b>WEIGHT</b>	4.25lb (1.4kg)

# 04 Flexible Impeller Pumps

BRONZE



## 777 Bronze Pedestal Flexible Impeller Pump

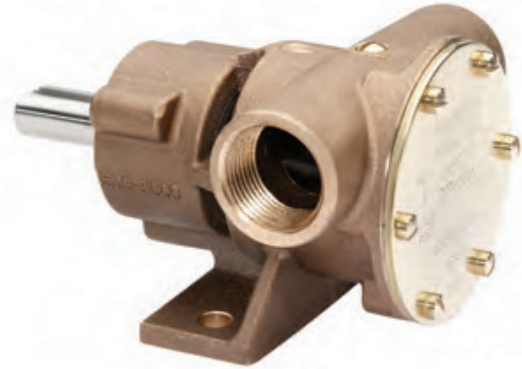

### SPECIFICATIONS

<b>MAX FLOW RATE</b>	17.8 GPM (80 LPM)
<b>MAX PRESSURE</b>	26 psi (1.8 bar) or 60' (18.3m) of head
<b>SELF-PRIMING</b>	8-10' (2.4-3m) dry, 20-22' (6.1-6.7m) wet
<b>PORTS</b>	1" (25mm) NPTF
<b>BODY</b>	Bronze
<b>LIQUID TEMPERATURE RANGE</b>	Neoprene - 45°F (7°C) to 160°F (71°C) Nitrile - 50°F (10°C) to 160°F (71°C)
<b>SHAFT</b>	Stainless steel
<b>SEAL</b>	Nitrile lip or face type
<b>IMPELLER</b>	Neoprene, nitrile
<b>DIMENSIONS</b>	3.6" high x 4-3/4" long x 6.3" wide (90mm x 120mm x 159mm)
<b>WEIGHT</b>	5.8lb (2.6kg)

## 18370 Bronze Pedestal Pump & 52270 Series



### SPECIFICATIONS

	MODEL 18370 (US ONLY)	MODEL 52220
<b>MAX FLOW RATE</b>	60 GPM (270 LPM)	60 GPM (270 LPM)
<b>SELF-PRIMING</b>	7.8' (2.4m)	7.8' (2.4m)
<b>PORTS</b>	2" (51mm) NPT	2" flanged or 2" (51mm) BSP
<b>BODY</b>	Bronze	Bronze, iron bearing housing
<b>LIQUID TEMPERATURE RANGE</b>	45°F (7°C) to 180°F (82°C)	45°F (7°C) to 180°F (82°C)
<b>SHAFT</b>	Stainless steel, 1" (25mm) diameter	Stainless steel, 1" (25mm) diameter
<b>SEAL</b>	Carbon/ceramic mechanical	Carbon/ceramic mechanical
<b>BEARINGS</b>	Twin row, ball type	Twin row, ball type
<b>IMPELLER</b>	Neoprene/nitrile	Neoprene/nitrile
<b>DIMENSIONS</b>	10.9" high x 8" long x 5.1" wide (276mm x 170mm x 128mm)	11" high x 7" long x 5" wide (79mm x 178mm x 127mm)
<b>WEIGHT</b>	19lb (8.6kg)	19.8lb (9kg)

## 6400 Bronze Pedestal Pump



### SPECIFICATIONS

<b>MAX FLOW RATE</b>	44.4 GPM (200 LPM)
<b>MAX PRESSURE</b>	26 psi (1.8 bar) or 60' (18.3m) of head
<b>SELF-PRIMING</b>	8-10' (2.4-3m) dry, 15-22' (4.6-6.7m) wet
<b>PORTS</b>	1-1/4" (32mm) NPTF
<b>BODY</b>	Bronze
<b>LIQUID TEMPERATURE RANGE</b>	Neoprene - 45°F (7°C) to 180°F (82°C) Nitrile - 50°F (10°C) to 180°F (82°C)
<b>SHAFT</b>	Bronze, 1-1/4" (32mm) diameter
<b>SEAL</b>	Carbon ceramic face type
<b>IMPELLER</b>	Neoprene
<b>DIMENSIONS</b>	4.9" high x 5.9" long x 8.1" wide (123mm x 149mm x 204mm)
<b>WEIGHT</b>	10.5lb (4.8kg)

## 51510 & 51520 Series

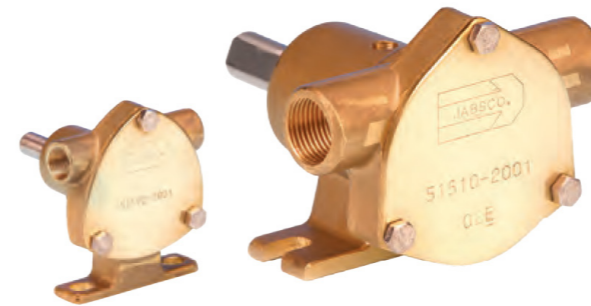

### SPECIFICATIONS

	MODEL 51510	MODEL 51520
<b>MAX FLOW RATE</b>	2.2 GPM (10 LPM)	4.4 GPM (20 LPM)
<b>SELF-PRIMING</b>	4.9' (1.5m)	4.9' (1.5m)
<b>PORTS</b>	3/8" (10mm) BSP or 3/8" (10mm) NPT	3/8" (10mm) BSP or 3/8" (10mm) NPT
<b>BODY</b>	Bronze	Bronze
<b>LIQUID TEMPERATURE RANGE</b>	45°F (7°C) to 180°F (82°C)	45°F (7°C) to 180°F (82°C)
<b>SHAFT</b>	Stainless steel, 1" (25mm) diameter	Stainless steel, 1" (25mm) diameter
<b>SEAL</b>	Carbon/ceramic mechanical	Carbon/ceramic mechanical
<b>BEARINGS</b>	Sealed ball bearings	Sealed ball bearings
<b>IMPELLER</b>	Neoprene	Neoprene
<b>DIMENSIONS</b>	3.6" high x 3" long x 2.4" wide (92mm x 80mm x 60mm)	3-1/4" high x 3" long x 3-1/2" wide (95mm x 80mm x 85mm)
<b>WEIGHT</b>	1.4lb (0.6kg)	1.5lb (0.7kg)

# 04 Flexible Impeller Pumps

BRONZE



## 52040 & 52580 Series



### SPECIFICATIONS

	MODEL 52040 (EUROPEAN ONLY)	MODEL 52580
MAX FLOW RATE	8.9 GPM (40 LPM)	17.8 GPM (80 LPM)
SELF-PRIMING	7.8' (2.4m)	7.8' (2.4m)
PORTS	3/4" (19mm) BSP	1" (25mm) BSP, 1" (25mm) NPT
BODY	Bronze	Bronze
LIQUID TEMPERATURE RANGE	45°F (7°C) to 180°F (82°C)	45°F (7°C) to 180°F (82°C)
SHAFT	Stainless steel, 1" (25mm) diameter	Stainless steel, 1" (25mm) diameter
SEAL	Lip type	Carbon/ceramic mechanical
BEARINGS	Twin row, ball type	Twin row, ball type
IMPELLER	Neoprene/nitrile	Neoprene/nitrile
DIMENSIONS	5" high x 4" long x 3" wide (128mm x 106mm x 78mm)	6-1/2" high x 5" long x 4" wide (180mm x 120mm x 100mm)
WEIGHT	3.3lb (1.5kg)	7.3lb (3.3kg)

## 52200 & 52220 Series

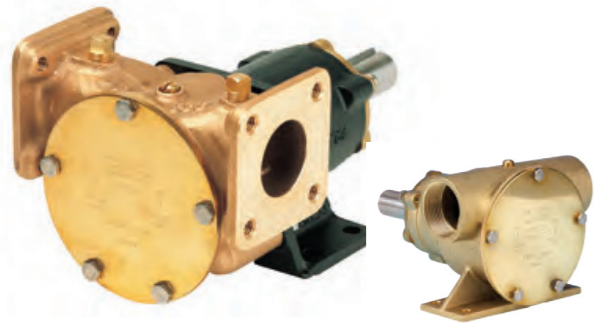

### SPECIFICATIONS

	MODEL 52200	MODEL 52220
MAX FLOW RATE	44.5 GPM (200 LPM)	44.5 GPM (200 LPM)
SELF-PRIMING	7.8' (2.4m)	7.8' (2.4m)
PORTS	1-1/2" (38mm) BSP	1-1/2" (38mm) flange
BODY	Bronze	Bronze
LIQUID TEMPERATURE RANGE	45°F (7°C) to 180°F (82°C)	45°F (7°C) to 180°F (82°C)
SHAFT	Stainless steel, 1" (25mm) diameter	Stainless steel, 1" (25mm) diameter
SEAL	Carbon/ceramic mechanical	Carbon/ceramic mechanical
BEARINGS	Twin row, ball type	Twin row, ball type
IMPELLER	Neoprene/nitrile	Neoprene/nitrile
DIMENSIONS	8" high x 6" long x 5" wide (204mm x 150mm x 120mm)	10-1/2" high x 6" long x 6" wide (276mm x 152mm x 146mm)
WEIGHT	11lb (5kg)	15.4lb (7kg)

## 11860 & 11870 Series



### SPECIFICATIONS

	MODEL 11860	MODEL 11870
CLUTCH VOLTAGE	12V or 24V DC	12V or 24V DC
MAX FLOW RATE	23 GPM (87 LPM)	62 GPM (234 LPM)
SELF-PRIMING	7.8' (2.4m)	7.8' (2.4m)
PORTS	1" (25mm) NPT	1-1/4" (32mm)
BODY	Bronze	Bronze
LIQUID TEMPERATURE RANGE	45°F (7°C) to 180°F (82°C)	45°F (7°C) to 180°F (82°C)
SHAFT	Stainless steel	Stainless steel
SEAL	Carbon/ceramic mechanical	Carbon/ceramic mechanical
BEARINGS	Twin row, ball type	Twin row, ball type
BELT	2 groove A, 1 groove B	2 groove A, 1 groove B
PULLEY	7" (178mm) diameter	7" (178mm) diameter
IMPELLER	Neoprene/nitrile	Neoprene/nitrile
DIMENSIONS	6.2" high x 5.4" long x 4.9" wide (157mm x 137mm x 125mm)	8.2" high x 6.1" long x 7.1" wide (208mm x 154mm x 179mm)
WEIGHT	15lb (6.8kg)	19.5lb (8.9kg)

## 50580 Series



### SPECIFICATIONS

CLUTCH VOLTAGE	12V or 24V DC
MAX FLOW RATE	17.8 GPM (80 LPM)
SELF-PRIMING	7.8' (2.4m)
PORTS	1" (25mm) BSP, 1" (25mm) NPT
BODY	Bronze
LIQUID TEMPERATURE RANGE	45°F (7°C) to 180°F (82°C)
SHAFT	Stainless steel
SEAL	Carbon/ceramic mechanical
BEARINGS	Twin row, ball type
BELT	2 groove A, 1 groove B
PULLEY	7" (178mm) diameter
IMPELLER	Neoprene/nitrile
DIMENSIONS	6-1/2" high x 5" long x 7" wide (160mm x 120mm x 178mm)
WEIGHT	11lb (5kg)

# 04 Flexible Impeller Pumps

BRONZE



## 50200 & 50220 Series



### SPECIFICATIONS

	MODEL 50200 (EUROPEAN ONLY)	MODEL 50220 (EUROPEAN ONLY)
CLUTCH VOLTAGE	12V or 24V DC	12V or 24V DC
MAX FLOW RATE	44.5 GPM (200 LPM)	44.5 GPM (200 LPM)
SELF-PRIMING	7.8' (2.4m)	7.8' (2.4m)
PORTS	1-1/2" (38mm) BSP	1-1/2" (38mm) flange
BODY	Bronze	Bronze
LIQUID TEMPERATURE RANGE	45°F (7°C) to 180°F (82°C)	45°F (7°C) to 180°F (82°C)
SHAFT	Stainless steel	Stainless steel
SEAL	Carbon/ceramic mechanical	Carbon/ceramic mechanical
BEARINGS	Twin row, ball type	Twin row, ball type
BELT	2 groove A, 1 groove B	2 groove A, 1 groove B
PULLEY	7" (178mm) diameter	7" (178mm) diameter
IMPELLER	Neoprene/nitrile	Neoprene/nitrile
DIMENSIONS	9-1/2" high x 6" long x 7" wide (239mm x 153mm x 178mm)	9-1/2" high x 6" long x 7" wide (239mm x 153mm x 178mm)
WEIGHT	25lb (11.2kg)	25lb (11.2kg)

## 18330 & 50270 Series



### SPECIFICATIONS

	MODEL 18330	MODEL 50270
CLUTCH VOLTAGE	12V or 24V DC	12V or 24V DC
MAX FLOW RATE	83 GPM (314 LPM)	60 GPM (270 LPM)
SELF-PRIMING	7.8' (2.4m)	7.8' (2.4m)
PORTS	2" (51mm) NPT	2" (51mm) BSP 2" (51mm) flange
BODY	Bronze	Bronze
LIQUID TEMPERATURE RANGE	45°F (7°C) to 180°F (82°C)	45°F (7°C) to 180°F (82°C)
SHAFT	Stainless steel	Stainless steel
SEAL	Carbon/ceramic mechanical	Carbon/ceramic mechanical
BEARINGS	Twin row, ball type	Twin row, ball type
BELT	2 groove A, 1 groove B	2 groove A, 1 groove B
PULLEY	7" (178mm) diameter	7" (178mm) diameter
IMPELLER	Neoprene/nitrile	Neoprene/nitrile
DIMENSIONS	12.4" high x 5.9" long x 5-3/4" wide (316mm x 151mm x 146mm)	10" high x 7" long x 7" wide (264mm x 170mm x 178mm)
WEIGHT	24lb (11kg)	27lb (12.2kg)



# Flexible Impeller Pumps 04

STAINLESS STEEL

## 28230 & 28240 Series



### FEATURES

- Self-priming from dry up to 16.4' (5m)
- Flows up to 10.6 GPM (40 LPM)
- Pressure up to 43.5 psi (3 bar)
- Handles hard or soft solids - 0.2" (5mm) maximum diameter
- Tolerates abrasive wear - replaceable wearplate
- Non-pulsating flow, proportional to speed
- Handles viscosities up to 4,000 cP
- Minimal shear to thixotropic fluids
- Easy to service and maintain
- Fits IEC standard motor B3/B14, frame 80 (model 28240)

### SPECIFICATIONS

MAX PRESSURE	Standard - 36 psi (2.5 bar) High - 43.5 psi (3 bar)
PORTS	3/4" (19mm) BSP internal thread to BS21 DIN2999
PUMP HEAD	Stainless steel 316, as-cast interior and exterior finish
SHAFT	Stainless steel 316
SEAL	Carbon/ceramic mechanical face seal, nitrile or FKM elastomer  Optional - Tungsten carbide/ceramic hard faced mechanical seal, nitrile lip seal on shaft sleeve, carbon/ceramic flushed seal, tungsten carbide/ceramic hard faced flush seal
BEARINGS	Model 28230 - greased ball bearings, epoxy-coated, cast iron housing Model 28240 - uses motor bearings with epoxy-coated, cast iron motor adapter
END COVER	Stainless steel 316
IMPELLER	Neoprene, EPDM, nitrile, FKM
WEIGHT	Model 28230 - 6.8lb (2.8kg) Model 28240 - 5.7lb (2.6kg)

## 28330 & 28340 Series

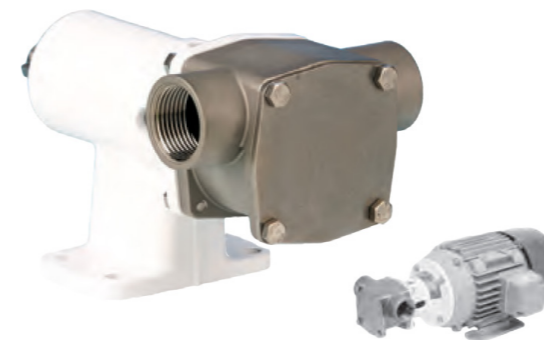

### FEATURES

- Self-priming from dry up to 16.4' (5m)
- Flows up to 21 GPM (80 LPM)
- Pressure up to 58 psi (4 bar)
- Handles hard or soft solids - 0.2" (5mm) maximum diameter
- Tolerates abrasive wear - replaceable wearplate
- Non-pulsating flow, proportional to speed
- Handles viscosities up to 4,000 cP
- Minimal shear to thixotropic fluids
- Fits IEC standard motor B3/B14, frame 80 (model 28340)
- Easy to service and maintain

### SPECIFICATIONS

MAX PRESSURE	Standard - 36 psi (2.5 bar) High - 58 psi (4 bar)
PORTS	1" (25mm) BSP internal thread to BS21 DIN2999
PUMP HEAD	Stainless steel 316, as-cast interior and exterior finish
SHAFT	Model 28330 - stainless steel 316 Model 28340 - stainless steel 316, shaft extension
SEAL	Carbon/ceramic mechanical face seal, nitrile or FKM elastomer  Optional - Tungsten carbide/ceramic hard faced mechanical seal, nitrile lip seal on shaft sleeve, carbon/ceramic flushed seal, tungsten carbide/ceramic hard faced flush seal
BEARINGS	Model 28330 - greased ball bearings, epoxy-coated, cast iron housing Model 28340 - uses motor bearings with epoxy-coated, cast iron motor adapter
END COVER	Stainless steel 316
IMPELLER	Neoprene, EPDM, nitrile, FKM
WEIGHT	Model 28330 - 9.3lb (4.2kg) Model 28340 - 7.3lb (3.3kg)



# 04 Flexible Impeller Pumps

STAINLESS STEEL



## 28430 & 28440 Series

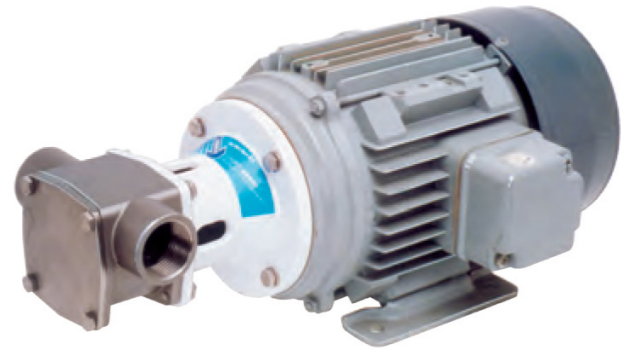

### FEATURES

- Self-priming from dry up to 16.4' (5m)
- Flows up to 52.8 GPM (200 LPM)
- Pressure up to 58 psi (4 bar)
- Handles hard or soft solids 0.4" (9mm) maximum diameter
- Tolerates abrasive wear - replaceable wearplate
- Non-pulsating flow, proportional to speed
- Handles viscosities up to 10,000 cP
- Minimal shear to thixotropic fluids
- Fits IEC standard motor B3/B14, frame 90 (model 28440)
- Easy to service and maintain

### SPECIFICATIONS

<b>MAX PRESSURE</b>	Standard - 36 psi (2.5 bar) High - 58 psi (4 bar)
<b>PORTS</b>	1-1/2" (38mm) BSP internal thread to BS21 DIN2999
<b>PUMP HEAD</b>	Stainless steel 316, as-cast interior and exterior finish
<b>SHAFT</b>	Model 28430 - stainless steel 316 Model 28440 - stainless steel 316, shaft extension
<b>SEAL</b>	Carbon/ceramic mechanical face seal, nitrile or FKM elastomer  Optional - Tungsten carbide/ceramic hard faced mechanical seal, nitrile lip seal on shaft sleeve, carbon/ceramic flushed seal, tungsten carbide/ceramic hard faced flush seal
<b>BEARINGS</b>	Model 28430 - greased ball bearings Model 28440 - epoxy-coated, cast iron housing
<b>END COVER</b>	Stainless steel 316
<b>IMPELLER</b>	Neoprene, EPDM, nitrile, FKM
<b>WEIGHT</b>	Model 28430 - 19.2lb (8.7kg) Model 28440 - 14.1lb (6.4kg)

## 28530 & 28540 Series



### FEATURES

- Self-priming from dry up to 14.8' (4.5 m)
- Flows up to 97.7 GPM (370 LPM)
- Pressure up to 43.5 psi (3 bar)
- Handles hard or soft solids 1/2" (13mm) maximum diameter
- Tolerates abrasive wear - replaceable wearplate
- Non-pulsating flow, proportional to speed
- Handles viscosities up to 50,000 cP
- Minimal shear to thixotropic fluids
- Fits IEC standard motor B3/B14, frame 100 (model 28540)
- Easy to service and maintain

### SPECIFICATIONS

<b>MAX PRESSURE</b>	Medium - 36 psi (2.5 bar) High - 43.5 psi (3 bar)
<b>PORTS</b>	2" (51mm) BSP external thread to BS21 DIN2999
<b>PUMP HEAD</b>	Stainless steel 316, as-cast interior and exterior finish
<b>SHAFT</b>	Model 28530 - stainless steel 316
<b>SEAL</b>	Carbon/ceramic mechanical face seal, nitrile or FKM elastomer  Optional - Tungsten carbide/ceramic hard faced mechanical seal, nitrile lip seal on shaft sleeve, carbon/ceramic flushed seal, tungsten carbide/ceramic hard faced flush seal
<b>BEARINGS</b>	Model 28530 - greased ball bearings, epoxy-coated, cast iron housing  Model 28540 - uses motor bearings with epoxy-coated, cast iron motor adapter
<b>END COVER</b>	Stainless steel 316
<b>IMPELLER</b>	Neoprene, EPDM, nitrile, FKM
<b>WEIGHT</b>	Model 28530 - 32lb (14.5kg) Model 28540 - 21.4lb (9.7kg)

# 04 Flexible Impeller Pumps

STAINLESS STEEL



## 30510 Industrial Stainless Steel Pedestal & Close-Coupled Flex Pump



Use where single or variable speed operation and 316 stainless steel material is desirable. Self-priming, 8 GPM (30 LPM) flow and debris-tolerant. A nitrile impeller is ideal for oil-based products. Use neoprene for water and general-purpose pumping. Use FKM for hydrocarbons and most solvents.

Optional EPDM impeller kit (7614-0002) for hygienic applications and some ketone solvents. Use a tungsten carbide seal when pumping highly corrosive or abrasive fluids. Long-lasting AC induction motor has no brushes to wear out. Do not pump gasoline or other flammable liquids. Motor is not explosion-proof. Do not run dry.

For pump head-only models (30510-2xxx), select NEMA 56 C-frame C-face motor rated at 3/4 HP at 1750 rpm with appropriate service factor. Motor must handle high-axial loads. Front ball bearing locked against axial movement is recommended. Motor must deliver 1.5ft-lbs and 4.3ft-lbs torque minimum in forward and reverse directions, respectively. Use only capacitor-start motors.

For pedestal-mount models (30510-0xxx) operating at 1750 rpm, select a 3/4 HP or 1-1/2 HP motor for standard or high-pressure impellers, respectively, with an appropriate service factor. For high-pressure impellers, the motor must supply 3ft-lbs or 6.9ft-lbs of torque minimum for forward and reverse operation, respectively. Rated flow is based on neoprene impeller pumping water. Reduce rated flow 10 percent for nitrile, FKM and EPDM standard impellers. Reduce rated flow 15 percent for nitrile, FKM and EPDM high-pressure impellers.

### SPECIFICATIONS

<b>VOLTAGE</b>	60Hz - 115V AC, single phase, non-CE
<b>MAX FLOW RATE</b>	8.2 GPM (31 LPM)
<b>MAX PRESSURE</b>	Standard - 30 psi (2.1 bar) or 70' (21.3m) of head High - 60 psi (4.2 bar) or 139' (42.4m) of head
<b>SELF-PRIMING</b>	Neoprene/nitrile - 8-10' (2.4-3m) dry, 18-22' (5.5-6.7m) wet FKM/EPDM - 4-6' (1.2-1.8m) dry, 18-22' (5.5-6.7m) wet
<b>PORTS</b>	3/4" (19mm) NPTF
<b>MOTOR</b>	3/4 HP, TEFC AC induction type 56 C-frame, C-face 6' (1.8m) power cord with 3-prong grounded plug Thermal overload protection
<b>BODY</b>	Stainless steel 316
<b>LIQUID TEMPERATURE RANGE</b>	Neoprene - 45°F (7°C) to 180°F (82°C) Nitrile - 50°F (10°C) to 180°F (82°C) FKM - 60°F (15°C) to 180°F (82°C) EPDM - 45°F (7°C) to 185°F (85°C)
<b>SHAFT</b>	Stainless steel 316
<b>SEAL</b>	Mechanical carbon or tungsten carbide on ceramic
<b>IMPELLER</b>	Neoprene, nitrile, FKM, optional EPDM
<b>DIMENSIONS</b>	Pump and motor - 9.1" high x 8.9" long x 16" wide (230mm x 224mm x 403mm) Pump head - 6.6" high x 6.6" long x 5-3/4" wide (168mm x 168mm x 145mm) Pedestal mount - 4-3/4" high x 4-3/4" long x 9-1/4" wide (120mm x 120mm x 233mm)
<b>WEIGHT</b>	Pump and motor - 36lb (16.3kg) Pump head - 7.5lb (3.4kg) Pedestal mount - 8.5lb (3.9kg)



## 30520 Industrial Stainless Steel Pedestal & Close-Coupled Flex Pump



Use where single or variable speed operation is desirable. Self-priming, 22 GPM flow and debris-tolerant. A nitrile impeller is ideal for oil-based products. Use neoprene for water and general-purpose pumping. Use FKM for hydrocarbons and most solvents. Optional EPDM impeller kit (8981-0002) for hygienic applications and some ketone solvents. Use tungsten carbide seal when pumping highly-corrosive or abrasive fluids. Do not pump gasoline or other flammable liquids. Motor is not explosion-proof. Do not run dry.

For pump head-only models (30520-2xxx), select NEMA H145 TC-frame C-face motor rated at 1-1/2 HP at 1750 rpm with appropriate service factor. Motor must handle high-axial loads. Front ball bearing locked against axial movement is recommended. Motor must deliver 4.8ft-lbs and 11.2ft-lbs torque minimum in forward and reverse directions, respectively. Use only capacitor-start motors.

For pedestal mount models (30520-0xxx) operating at 1750 rpm, select a 1-1/2 HP or 3 HP motor for standard or high-pressure impellers, respectively, with an appropriate service factor. For high-pressure impellers, the motor must supply 7.9ft-lbs or 16.3ft-lbs of torque minimum for forward and reverse operation, respectively. Rated flow is based on neoprene impeller pumping water. Reduce rated flow 10 percent for nitrile, FKM and EPDM standard impellers. Reduce rated flow 15 percent for nitrile, FKM and EPDM high-pressure impellers.

### SPECIFICATIONS

<b>VOLTAGE</b>	60Hz - 115V and 230V AC, single phase, non-CE
<b>MAX FLOW RATE</b>	22 GPM (83 LPM)
<b>MAX PRESSURE</b>	Standard - 30 psi (2.1 bar) or 69' (21m) of head High - 60 psi (4.2 bar) or 138' (42m) of head
<b>SELF-PRIMING</b>	Neoprene/nitrile - 8-10' (2.4-3m) dry, 18-22' (5.5-6.7m) wet FKM/EPDM - 4-6' (1.2-1.8m) dry, 18-22' (5.5-6.7m) wet
<b>PORTS</b>	1" (25mm) NPTF
<b>MOTOR</b>	1-1/2 HP, TEFC AC induction type H145 TC-frame, C-face 6' (1.8m) power cord with 3-prong grounded plug Thermal overload protection
<b>BODY</b>	Epoxy 316
<b>LIQUID TEMPERATURE RANGE</b>	Neoprene - 45°F (7°C) to 180°F (82°C) Nitrile - 50°F (10°C) to 180°F (82°C) FKM - 60°F (15°C) to 180°F (82°C) EPDM - 45°F (7°C) to 185°F (85°C)
<b>SHAFT</b>	Epoxy 316 sleeve
<b>SEAL</b>	Mechanical carbon or tungsten carbide on ceramic
<b>IMPELLER</b>	Neoprene, nitrile, FKM, optional EPDM
<b>DIMENSIONS</b>	Pump and motor - 8.4" high x 8.9" long x 18-1/4" wide (213mm x 224mm x 460mm) Pump head - 6.6" high x 6.6" long x 7-1/2" wide (168mm x 168mm x 189mm) Pedestal mount - 4-3/4" high x 4-3/4" long x 9-1/4" wide (120mm x 120mm x 233mm)
<b>WEIGHT</b>	Pump and motor - 36lb (16.3kg) Pump head - 7.5lb (3.4kg) Pedestal mount - 8.5lb (3.9kg)



# 04 Flexible Impeller Pumps

STAINLESS STEEL

**JABSCO**

## 30530 Industrial Stainless Steel Pedestal & Close-Coupled Flex Pump



Use where single or variable speed operation and 316 stainless steel material are desirable. Self-priming, 50 GPM (189 LPM) flow and debris-tolerant. A nitrile impeller is ideal for oil-based products. Use neoprene for water and general purpose pumping. Use FKM for hydrocarbons and most solvents. Optional standard EPDM impeller kit (14346-0002) for hygienic applications and some ketone solvents. Use tungsten carbide seal when pumping highly corrosive or abrasive fluids. Do not pump gasoline or other flammable liquids. Motor is not explosion-proof. Do not run dry.

For pump head-only models (30530-2xxx) select NEMA 184 TC-frame C-face motor rated at 5 HP at 1750 rpm with appropriate service factor. Motor must handle high-axial loads. Front ball bearing locked against axial movement is recommended. Motor must deliver 14.5ft-lbs and 43ft-lbs torque minimum in forward and reverse directions, respectively.

For standard impellers only. Use only capacitor-start motors. For pedestal-mount models (30530-0xxx) operating at 1750 rpm, select a 3 HP or 6 HP motor for standard or high-pressure impellers, respectively, with an appropriate service factor. For high-pressure impellers, the motor must supply 26ft-lbs or 40ft-lbs of torque minimum for forward and reverse operation, respectively. Rated flow is based on neoprene impeller pumping water. Reduce rated flow 10 percent for nitrile, FKM and EPDM standard impellers. Reduce rated flow 15 percent for nitrile, FKM and EPDM high-pressure impellers.

### SPECIFICATIONS

<b>VOLTAGE</b>	60Hz - 230V and 460V AC, three phase, non-CE
<b>MAX FLOW RATE</b>	50 GPM (189 LPM)
<b>MAX PRESSURE</b>	Standard - 30 psi (2.1 bar) or 69' (21m) of head High - 60 psi (4.2 bar) or 138' (42m) of head
<b>SELF-PRIMING</b>	Neoprene/nitrile - 8-10' (2.4-3m) dry, 18-22' (5.5-6.7m) wet FKM/EPDM - 4-6' (1.2-1.8m) dry, 18-22' (5.5-6.7m) wet
<b>PORTS</b>	1-1/2" (38mm) NPTF
<b>MOTOR</b>	5 HP, TEFC AC induction type 184 TC-frame, C-face 6' (1.8m) power cord with 3-prong grounded plug Thermal overload protection
<b>BODY</b>	Stainless steel 316
<b>LIQUID TEMPERATURE RANGE</b>	Neoprene - 45°F (7°C) to 180°F (82°C) Nitrile - 50°F (10°C) to 180°F (82°C) FKM - 60°F (15°C) to 180°F (82°C) EPDM - 45°F (7°C) to 185°F (85°C)
<b>SHAFT</b>	Stainless steel 316
<b>SEAL</b>	Mechanical carbon or tungsten carbide on ceramic
<b>IMPELLER</b>	Neoprene, nitrile, FKM, optional EPDM
<b>DIMENSIONS</b>	Pump and motor - 9" high x 10.4" long x 23-1/4" wide (227mm x 262mm x 586mm) Pump head - 9" high x 9" long x 8.3" wide (227mm x 227mm x 210mm) Pedestal mount - 5-3/4" high x 6.9" long x 11.6" wide (145mm x 174mm x 292mm)
<b>WEIGHT</b>	Pump and motor - 93.5lb (42.5kg) Pump head - 30lb (13.6kg) Pedestal mount - 21lb (9.5kg)

## 30540 Industrial Stainless Steel Pump

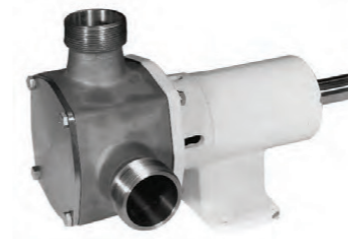

For pedestal-mount models operating at 1750 rpm, select a 5 HP or 7 HP motor for standard or high-pressure impellers, respectively, with an appropriate service factor. For standard-pressure impellers, the motor must supply 21ft-lbs or 38ft-lbs of torque minimum for forward and reverse operation, respectively. For high-pressure impellers, the motor must supply 28ft-lbs or 49ft-lbs of torque minimum for forward and reverse operation, respectively. Optional standard EPDM impeller kit (8963-0002) and high-pressure EPDM impeller kit (8600-0002).

Rated flow is based on standard neoprene impeller pumping water. Reduce rated flow 10 percent for nitrile, FKM, and EPDM standard and high-pressure impellers.

### SPECIFICATIONS

<b>MAX FLOW RATE</b>	105 GPM (397 LPM)
<b>MAX PRESSURE</b>	Standard - 20 psi (1.4 bar) or 46' (14m) of lift High - 60 psi (4.2 bar) or 138' (42m) of lift
<b>SELF-PRIMING</b>	Neoprene/nitrile - 8-10' (2.4-3m) dry, 18-22' (5.5-6.7m) wet FKM/EPDM - 4-6' (1.2-1.8m) dry, 18-22' (5.5-6.7m) wet
<b>PORTS</b>	2" (51mm) NPTM
<b>BODY</b>	Stainless steel 316
<b>LIQUID TEMPERATURE RANGE</b>	Neoprene - 45°F (7°C) to 180°F (82°C) Nitrile - 50°F (10°C) to 180°F (82°C) FKM - 60°F (15°C) to 180°F (82°C) EPDM - 45°F (7°C) to 185°F (85°C)
<b>SHAFT</b>	Stainless steel 316
<b>SEAL</b>	Mechanical carbon-on-ceramic or carbon-on-tungsten, nitrile or FKM
<b>IMPELLER</b>	Neoprene, nitrile, FKM, EPDM
<b>DIMENSIONS</b>	8-3/4" high x 7-1/2" long x 14-1/8" wide (223mm x 191mm x 359mm)
<b>WEIGHT</b>	8.5lb (3.9kg)

## 4720 Stainless Steel Utility Flex Pump



Use where stainless steel, self-priming, 11 GPM (41 LPM) flow, debris-tolerance, and portable 115V AC or 230V AC 60Hz operation is desired. A nitrile impeller is ideal for oil-based products. Use neoprene for water and general-purpose pumping. Motor is not explosion-proof. Do not run dry.

### MODELS

MODEL #	CE	VOLTAGE	IMPELLER	STYLE
4720-0001	No	115V and 230V AC	Neoprene	MPU, pedestal
4720-0003	No	115V and 230V AC	Nitrile	MPU, pedestal

### SPECIFICATIONS

<b>VOLTAGE</b>	60Hz - 115V and 230V AC, single phase, non-CE
<b>MAX FLOW RATE</b>	11 GPM (41 LPM)
<b>MAX PRESSURE</b>	21 psi (1.5 bar) or 50' (15.2m) of head
<b>SELF-PRIMING</b>	8-10' (2.4-3m) dry, 18-22' (5.5-6.7m) wet
<b>PORTS</b>	1/2" (13mm) NPTF
<b>MOTOR</b>	1/3 HP TEFC AC induction type 6' (1.8m) power cord with 3-prong grounded plug Thermal overload protection
<b>BODY</b>	Stainless steel
<b>LIQUID TEMPERATURE RANGE</b>	Neoprene - 45°F (7°C) to 180°F (82°C) Nitrile - 50°F (10°C) to 180°F (82°C)
<b>SHAFT</b>	Stainless steel 316
<b>SEAL</b>	Neoprene lip type
<b>IMPELLER</b>	Neoprene, nitrile
<b>DIMENSIONS</b>	8-1/4" high x 7-3/4" long x 13-1/8" wide (208mm x 195mm x 331mm)
<b>WEIGHT</b>	35lb (15.9kg)

# 04 Flexible Impeller Pumps

SANITARY INTRODUCTION



## Flexible Impeller Hygienic Positive Displacement Pump

Jabsco hygienic flexible impeller pumps handle low- and high-viscosity liquids, gels and pastes, and can pass suspended soft and hard solids with minimal damage. The output-flow is smooth, steady and totally pulsation-free, and their gentle pumping action will not break down shear-sensitive or fragile liquids. Designed to be cleaned in place or easily strip-cleaned, Xylem Jabsco flexible impeller pumps frequently offer a more suitable and cost-effective alternative to many other pump types.

### OPTIONS

#### PEDESTAL PUMPS

- Foot-mounted to couple to gearbox or belt-drive
- Hygienic rubber impeller
- Long-life mechanical shaft seal
- All 316 grade stainless steel parts with high-surface finish
- Used in food, dairy, beverage, healthcare and cosmetics sectors

#### MOTOR MOUNT PUMPS

- Used in food, dairy, beverage, healthcare & cosmetics sectors
- Close-coupled to motor (unibloc); compact and economical
- Suitable for mounting onto standard IEC or NEMA motors
- Hygienic rubber impeller
- Long-life mechanical shaft seal
- All 316 grade stainless steel parts with high-surface finish

#### MILK TANKER PUMPS

- Specialized pumps for milk tanker loading at dairy farms
- Bulkhead-mounted for hydraulic drive
- Quick-release end-cover for winter drain-down and inspection
- Bypass option for effective CIP without the need to run the pump
- Hygienic rubber impeller

### DESIGN FEATURES

- Dry self-priming
- All 316 stainless steel parts with high-surface finish
- Hygienic rubber impeller leaves no taste or odor
- Elastomers certified to US 3A standard 18-03
- Pump certified to US 3A standard 02-11
- Long-life mechanical shaft seal
- Easy strip-to-clean
- USDA approved
- Variety of port types and impeller material options
- Chemical-resistant 316 stainless steel parts
- Rugged heavy-duty construction
- Replaceable wearplates
- Passes even hard metal particles without stalling
- Long-life mechanical shaft seal
- Variety of shaft seal options
- 3A variants – must be specified with HYG neoprene or EPDM
- Port options – tri-clamp, IDF, 3A, DIN 11851
- EPDM/nitrile certified to EN1935:2004

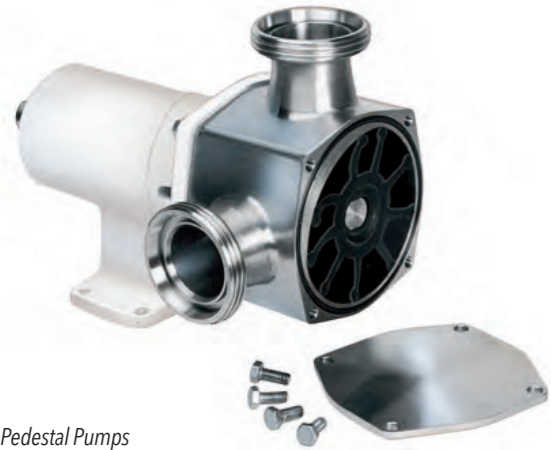

Pedestal Pumps

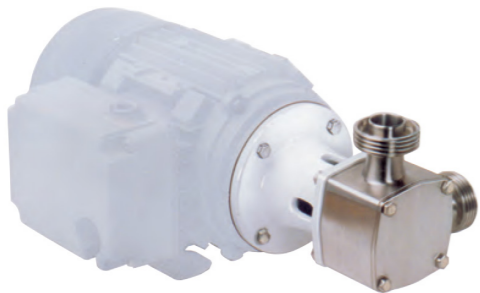

Motor Mount Pumps



Milk Tanker Pumps

### FLEXIBLE IMPELLER

	MODEL 282X0 (30550)		MODEL 283X0 (30560)		MODEL 284X0 (30570)		MODEL 285X0 (30580)		MODEL 286X0 (N/A)	
SIZE	40		80		200		370		500	
MOUNTING	Pedestal	Head Kit	Pedestal	Head Kit	Pedestal	Head Kit	Pedestal	Head Kit	Pedestal	Head Kit
MAX FLOW RATE	15.3 GPM (58 LPM)	15.3 GPM (58 LPM)	33.8 GPM (128 LPM)	33.8 GPM (128 LPM)	59.5 GPM (225 LPM)	59.5 GPM (225 LPM)	96 GPM (365 LPM)	96 GPM (365 LPM)	132 GPM (500 LPM)	132 GPM (500 LPM)
MAX PRESSURE	43 psi (3 bar)	43 psi (3 bar)	65 psi (4.5 bar)	65 psi (4.5 bar)	65 psi (4.5 bar)	65 psi (4.5 bar)	43 psi (3 bar)	43 psi (3 bar)	58 psi (4 bar)	58 psi (4 bar)
MAX SPEED	2500 rpm	2500 rpm	2500 rpm	2500 rpm	1800 rpm	1800 rpm	1500 rpm	1500 rpm	1500 rpm	1500 rpm
PORTS	1" (25mm)	1" (25mm)	1" (25mm)	1" (25mm)	1-1/4" (38mm)	1-1/4" (38mm)	2" (51mm)	2" (51mm)	2-1/4" (63mm)	2-1/4" (63mm)
LIQUID TEMPERATURE	Neoprene – 149°F (65°C), EPDM – 248°F (120°C)									
VISCOSITY	1–50,000 Cp									
DIMENSIONS	5.75" high x 6.5" long x 4.5" wide	4.5" high x 4.5" long x 4.5" wide	6.25" high x 8.5" long x 5" wide	5" high x 5.25" long x 5" wide	7" high x 10.25" long x 6.25" wide	6.25" high x 6.5" long x 6.25" wide	8.5" high x 13" long x 7.25" wide	8.5" high x 7.5" long x 7.25" wide	8.75" high x 18.75" long x 7.5" wide	7.5" high x 9" long x 7.5" wide
BARESHAF WEIGHT	6.4lb (2.9kg)	5.5lb (2.5kg)	9.7lb (4.4kg)	7.7lb (3.5kg)	20lb (9.1kg)	14.5lb (6.6kg)	32lb (14.7kg)	22lb (10kg)	48.5lb (22kg)	33lb (15kg)

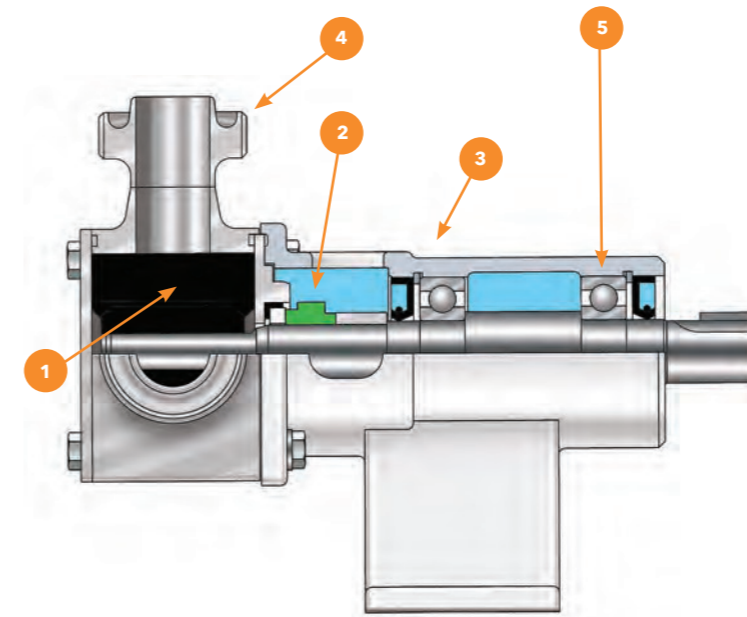

### CONSTRUCTION DETAILS

1. Food-grade rubber impeller available in neoprene, EPDM, and nitrile options which fully conform to today's stringent hygienic standards.
2. Wide variety of long-life, interchangeable seal types to suit many applications, making service & maintenance easy.
3. Choice of head kit or pedestal bearing housing satisfies the individual's requirement for unitization on larger models. Bulkhead-mounted pumps are available if the option of fitting to hydraulic drive is required.
4. Range of port options for maximum flexibility.
5. Long-life, high-specification bearings give over 1 million hours of life on a typical duty.

# 04 Flexible Impeller Pumps

STAINLESS STEEL SANITARY



## 28200 Series Stainless Steel Pedestal Pump & 28220 Head Kit Pump



### FEATURES

- Self-primers from dry up to 7.8' (2.4m)
- Flows up to 10.5 GPM (40 LPM)
- Pressure up to 43.5 psi (3 bar)
- Handles soft solids - 0.3" (8 mm) maximum diameter
- Certified to US 3A standard 02-11
- Clean-in-place (CIP) or easy strip clean
- Minimal shear to thixotropic fluids
- Easy to service and maintain
- EPDM/nitrile certified to EN1935:2004

### SPECIFICATIONS

<b>MAX PRESSURE</b>	Standard - 36 psi (2.5 bar) High - 58 psi (4 bar)
<b>PORTS</b>	Model 28200 - 1" (25mm) tri-clamp, 1" (25mm) IDF/ISS, 1" (25mm) RJT to BS1864 Model 28220 - 1" (25mm) 3A bevel seat, 1" (25mm) DIN11851, 1" (25mm) SMS 1145
<b>PUMP HEAD</b>	Stainless steel 316, machined interior and electro-polished exterior finish
<b>SHAFT</b>	Stainless steel 316
<b>SEAL</b>	Carbon/ceramic mechanical face seal, tungsten carbide/ceramic hard faced seal, flushed options for crystalizing fluids Food grade nitrile elastomer
<b>BEARINGS</b>	Twin single row, ball type
<b>END COVER</b>	Stainless steel 316
<b>IMPELLER</b>	3A food grade neoprene or EDPM
<b>WEIGHT</b>	6.4lb (2.9kg)

## 28300 Series Stainless Steel Pedestal Pump & 28320 Head Kit Pump



### FEATURES

- Self-primers from dry up to 16.4' (5m)
- Flows up to 21.2 GPM (80 LPM)
- Pressure up to 58 psi (4 bar)
- Handles soft solids - 0.47" (12mm) maximum diameter
- Certified to US 3A standard 02-11
- Clean-in-place (CIP) or easy strip clean
- Handles viscosities up to 50,000 cP
- Minimal shear to thixotropic fluids
- Fits IEC standard motor B3/B14, frame 80
- Easy to service and maintain
- EPDM/nitrile certified to EN1935:2004

### SPECIFICATIONS

<b>MAX PRESSURE</b>	Standard - 36 psi (2.5 bar) High - 58 psi (4 bar)
<b>PORTS</b>	Model 28300 - 1" (25mm) tri-clamp, 1" (25mm) IDF/ISS, 1" (25mm) RJT to BS1864 Model 28320 - 1" (25mm) 3A bevel seat, 1" (25mm) (DIN11851), 1" (25mm) SMS 1145
<b>PUMP HEAD</b>	Stainless steel 316, machined interior and electro-polished exterior finish
<b>SHAFT</b>	Model 28300 - stainless steel 316 Model 28320 - stainless steel 316, shaft extension
<b>SEAL</b>	Carbon/ceramic mechanical face seal, tungsten carbide/ceramic hard faced seal, flushed options for crystalizing fluids Food grade nitrile elastomer
<b>BEARINGS</b>	Model 28300 - greased ball bearings with epoxy-coated, cast iron housing Model 28320 - uses motor bearings with epoxy-coated, cast iron motor adapter
<b>END COVER</b>	Stainless steel 316
<b>IMPELLER</b>	3A neoprene or EDPM
<b>WEIGHT</b>	Model 28300 - 7.7lb (3.5kg) Model 28320 - 9.7lb (4.4kg)

## 28400 Series Stainless Steel Pedestal Pump & 28420 Head Kit Pump

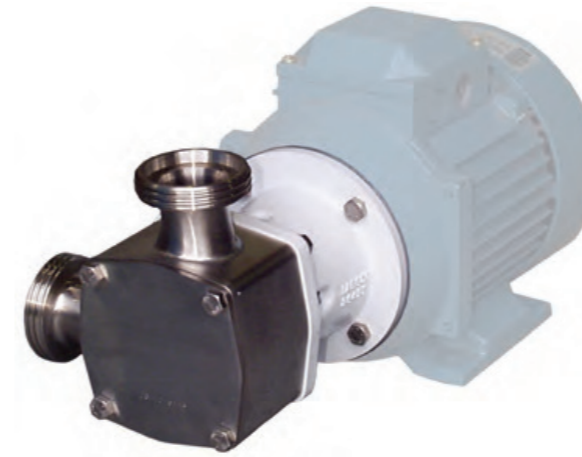

### FEATURES

- Self-primers from dry up to 16.4' (5m)
- Flows up to 52.8 GPM (200 LPM)
- Pressure up to 58 psi (4 bar)
- Handles soft solids - 0.63" (16 mm) maximum diameter
- Certified to US 3A standard 02-11
- Clean-in-place (CIP) or easy strip clean
- Handles viscosities up to 50,000 cP
- Minimal shear to thixotropic fluids
- Fits IEC standard motor B3/B14, frame 90 (model 28420)
- Easy to service and maintain
- EPDM/nitrile certified to EN1935:2004

### SPECIFICATIONS

<b>MAX PRESSURE</b>	Standard - 36 psi (2.5 bar) High - 58 psi (4 bar)
<b>PORTS</b>	1-1/4" (38mm) tri-clamp 1-1/4" (38mm) IDF/ISS 1-1/4" (38mm) RJT to BS1864 1-1/4" (38mm) 3A bevel seat 1.6" (40mm) DIN11851 1-1/4" (38mm) SMS 1145
<b>PUMP HEAD</b>	Stainless steel 316, machined interior and electro-polished exterior finish
<b>SHAFT</b>	Model 28400 - stainless steel 316 Model 28420 - stainless steel 316, shaft extension
<b>SEAL</b>	Carbon/ceramic mechanical face seal, tungsten carbide/ceramic hard faced seal, flushed options for crystalizing fluids Food grade nitrile elastomer
<b>BEARINGS</b>	Model 28400 - greased ball bearings with epoxy-coated, cast iron housing Model 28420 - uses motor bearings with epoxy-coated, cast iron motor adapter
<b>END COVER</b>	Stainless steel 316
<b>IMPELLER</b>	3A neoprene or EDPM
<b>WEIGHT</b>	Model 28400 - 20lb (9.1kg) Model 28420 - 14.6lb (6.6kg)

# 04 Flexible Impeller Pumps

STAINLESS STEEL SANITARY



## 28500 Series Stainless Steel Pedestal Pump & 28520 Head Kit Pump



### FEATURES

- Self-primers from dry up to 14.8' (4.5m)
- Flows up to 94 GPM (365 LPM)
- Pressure up to 43.5 psi (3 bar)
- Handles soft solids - 0.7" (18mm) maximum diameter
- Certified to US 3A standard 02-11
- Clean-in-place (CIP) or easy strip clean
- Handles viscosities up to 50,000 cP
- Minimal shear to thixotropic fluids
- Fits IEC standard motor B3/B14, frame 80 (model 28520)
- Easy to service and maintain
- EPDM/nitrile certified to EN1935:2004

### SPECIFICATIONS

<b>MAX PRESSURE</b>	Standard - 36 psi (2.5 bar) High - 43.5 psi (3 bar)
<b>PORTS</b>	2" (51mm) tri-clamp 2" (51mm) IDF/ISS 2" (51mm) RJT to BS1864 2" (51mm) 3A bevel seat 1.97" (50mm) DIN11851 2" (51mm) SMS 1145
<b>PUMP HEAD</b>	Stainless steel 316, machined interior and electro-polished exterior finish
<b>SHAFT</b>	Model 28500 - stainless steel 316 Model 28520 - stainless steel 316, shaft extension
<b>SEAL</b>	Carbon/ceramic mechanical face seal, tungsten carbide/ceramic hard faced seal, flushed options for crystalizing fluids Food grade nitrile elastomer
<b>BEARINGS</b>	Model 28500 - greased ball bearings with epoxy-coated, cast iron housing Model 28520 - uses motor bearings with epoxy-coated, cast iron motor adapter
<b>END COVER</b>	Stainless steel 316
<b>IMPELLER</b>	3A neoprene or EDPM
<b>WEIGHT</b>	Model 28500 - 32.4lb (14.7kg) Model 28520 - 22lb (10kg)



## 28600 Series Stainless Steel Pedestal Pump & 28620 Head Kit Pump



### FEATURES

- Self-primers from dry up to 16.4' (5m)
- Flows up to 137.4 GPM (520 LPM)
- Pressure up to 58 psi (4 bar)
- Handles soft solids - 0.7" (18mm) maximum diameter
- Certified to US 3A standard 02-11
- Clean-in-place (CIP) or easy strip clean
- Handles viscosities up to 50,000 cP
- Minimal shear to thixotropic fluids
- Fits IEC standard motor B3/B14, frame 90 (model 28420)
- Easy to service and maintain

### SPECIFICATIONS

<b>MAX PRESSURE</b>	Standard - 29 psi (2 bar) High - 72.1 psi (5 bar)
<b>PORTS</b>	2-1/4" (57mm) tri-clamp 2-1/4" (57mm) IDF/ISS 2-1/4" (57mm) RJT to BS1864 2-1/4" (57mm) 3A bevel seat 2.6 (66mm) DIN11851 2-1/4" (57mm) SMS 1145
<b>PUMP HEAD</b>	Stainless steel 316, machined interior and electro-polished exterior finish
<b>SHAFT</b>	Model 28260 - stainless steel 316, shaft extension Model 28620 - requires motor with special shaft
<b>SEAL</b>	Carbon/ceramic mechanical face seal, tungsten carbide/ceramic hard faced seal, flushed options for crystalizing fluids Food grade nitrile elastomer
<b>BEARINGS</b>	Model 28600 - greased ball bearings with epoxy-coated, cast iron housing Model 28620 - uses motor bearings with epoxy-coated, cast iron motor adapter
<b>END COVER</b>	Stainless steel 316
<b>IMPELLER</b>	3A neoprene
<b>WEIGHT</b>	Model 28600 - 48.5lb (22kg) Model 28620 - 33lb (15kg)



# 04 Flexible Impeller Pumps

STAINLESS STEEL SANITARY



## 30550 Series Sanitary Flexible Impeller Pump



### FEATURES

- Flow rate: nominal 10.5 GPM (40 LPM) at 1750 rpm
- Self-priming from dry up to 7.8' (2.4m)
- Pressure up to 58 psi (4 bar)
- Handles soft solids - 0.3" (8mm) maximum diameter
- Certified to US 3A standard 02-11
- Clean-in-place (CIP) or easy strip clean
- Handles viscosities up to 50,000 cP
- Minimal shear to thixotropic fluids
- Easy to service and maintain

### SPECIFICATIONS

<b>PUMP DESIGN</b>	Pedestal pump, pump head, close-coupled
<b>PORTS</b>	1" (25mm) ACME threads with bevel seat or clamp type
<b>MOTOR</b>	60Hz - 115V AC, single phase, 1/4 HP, 1750 RPM, TEFC, C-face, 56 C-frame
<b>BODY</b>	Stainless steel 316
<b>SHAFT</b>	Pedestal - stainless steel 316 Pump head/close-coupled - stainless steel 316 motor
<b>SEAL</b>	Mechanical carbon-on-ceramic or tungsten carbide, nitrile
<b>IMPELLER</b>	Neoprene or EPDM
<b>WEIGHT</b>	Pedestal - 5.5lb (2.5kg) Pump head - 7.5lb (3.4kg) Close-coupled - 36lb (16.3kg)

## 30560 Series Sanitary Flexible Impeller Pump



### FEATURES

- Flow rate: nominal 21.5 GPM (81 LPM) at 1750 rpm
- Self-priming from dry up to 7.8' (2.4m)
- Pressure up to 58 psi (4 bar)
- Handles soft solids - 0.47" (12 mm) maximum diameter
- Certified to US 3A standard 02-11
- Clean-in-place (CIP) or easy strip clean
- Handles viscosities up to 50,000 cP
- Minimal shear to thixotropic fluids
- Easy to service and maintain

### SPECIFICATIONS

<b>PUMP DESIGN</b>	Pedestal pump, pump head, close-coupled
<b>PORTS</b>	1" (25mm) ACME threads with bevel seat or clamp type
<b>MOTOR</b>	60Hz - 115V and 230V AC, single phase, 1-1/4 HP, H145 TC-frame, C-face, 1740 rpm, TEFC, overload protected, capacitor start, non-CE
<b>BODY</b>	Stainless steel 316
<b>SHAFT</b>	Stainless steel 316 Motor - stainless steel 316
<b>SEAL</b>	Mechanical carbon-on-ceramic or tungsten carbide, nitrile
<b>IMPELLER</b>	Neoprene or EPDM
<b>WEIGHT</b>	Pedestal - 8.5lb (3.9kg) Pump head - 12lb (5.5kg) Close-coupled - 56lb (25.4kg)

## 30570 Series Sanitary Flexible Impeller Pump



### FEATURES

- Flow rate - nominal 51 GPM (193 LPM) at 1750 rpm
- Self-priming from dry up to 7.8' (2.4m)
- Pressure up to 58 psi (4 bar)
- Handles soft solids - 0.63" (16mm) maximum diameter
- Certified to US 3A standard 02-11
- Clean-in-place (CIP) or easy strip clean
- Handles viscosities up to 50,000 cP
- Minimal shear to thixotropic fluids
- Easy to service and maintain

### SPECIFICATIONS

<b>PUMP DESIGN</b>	Pedestal pump, pump head, close-coupled
<b>PORTS</b>	1-1/4" (38mm) ACME threads with bevel seat or clamp type
<b>MOTOR</b>	60Hz - 230V and 460V AC, Three phase, 5 HP 1750 rpm, TEFC, C-face, 184 TC-frame, non-CE
<b>BODY</b>	Stainless steel 316
<b>SHAFT</b>	Stainless steel 316 Motor - stainless steel 316
<b>SEAL</b>	Mechanical carbon-on-ceramic or tungsten carbide, nitrile
<b>IMPELLER</b>	Neoprene or EPDM
<b>WEIGHT</b>	Pedestal - 21lb (9.5kg) Pump head - 30lb (18.6kg) Close-coupled - 93.5lb (42.5kg)

## 30580 Series Sanitary Flexible Impeller Pump



### FEATURES

- Flow rate - nominal 105 GPM (397 LPM) at 1750 rpm
- Self-priming from dry up to 7.8' (2.4m)
- Pressure up to 58 psi (4 bar)
- Handles soft solids - 0.7" (18mm) maximum diameter
- Certified to US 3A standard 02-11
- Clean-in-place (CIP) or easy strip clean
- Handles viscosities up to 50,000 cP
- Minimal shear to thixotropic fluids
- Easy to service and maintain

### SPECIFICATIONS

<b>PUMP DESIGN</b>	Pedestal pump
<b>PORTS</b>	2" (51mm) ACME threads with bevel seat or clamp type
<b>BODY</b>	Stainless steel 316
<b>SHAFT</b>	Stainless steel 316
<b>SEAL</b>	Mechanical carbon-on-ceramic or tungsten carbide, nitrile
<b>IMPELLER</b>	Neoprene or EPDM
<b>WEIGHT</b>	31lb (14.1kg)

# 04 Flexible Impeller Pumps

STAINLESS STEEL SANITARY



## 22060 Bulkhead/Milk Tanker Pump



### MODELS

MODEL #	CE	VOLTAGE	IMPELLER	STYLE
22060-10-5205	Yes	N/A	Sanitary neoprene	Flange, stainless

### FEATURES

- Flow rate - nominal 128 GPM (484 LPM) at 1450 rpm
- Self-priming from dry up to 7.8' (2.4m)
- Pressure up to 36.3 psi (2.5 bar)
- Handles soft solids - 0.7" (18mm) maximum diameter
- Certified to US 3A standard 02-11
- Clean-in-place (CIP) or easy strip clean
- Minimal shear to thixotropic fluids
- Easy to service and maintain

### SPECIFICATIONS

<b>PORTS</b>	2-1/4" (57mm) tri-clamp 2-1/4" (57mm) IDF/ISS 2-1/4" (57mm) RJT to BS1864 2-1/4" (57mm) 3A bevel seat 2.6" (66mm) DIN11851 2-1/4" (57mm) SMS1145
<b>BODY</b>	Stainless steel 316
<b>SHAFT</b>	Stainless steel 316
<b>SEAL</b>	Carbon/ceramic mechanical, food grade nitrile elastomer
<b>BEARINGS</b>	Twin single row, ball type with stainless steel 316 housing
<b>IMPELLER</b>	3A food grade neoprene
<b>WEIGHT</b>	50lb (23kg)

## 23930 Bulkhead/Milk Tanker Pump



### MODELS

MODEL #	CE	VOLTAGE	IMPELLER	STYLE
23930-5115	Yes	N/A	3A neoprene	Flange, stainless

### FEATURES

- Flow rate - nominal 185 GPM (700 LPM) at 1750 rpm
- Self-priming from dry up to 7.8' (2.4m)
- Pressure up to 21.7 psi (1.5 bar)
- Handles soft solids - 0.7" (18mm) maximum diameter
- Certified to US 3A standard 02-11
- Clean-in-place (CIP) or easy strip clean
- Minimal shear to thixotropic fluids
- Easy to service and maintain

### SPECIFICATIONS

<b>PORTS</b>	2-1/4" (57mm) tri-clamp 2-1/4" (57mm) IDF/ISS 2-1/4" (57mm) RJT to BS1864 2-1/4" (57mm) 3A bevel seat 2.6" (66mm) DIN11851 2-1/4" (57mm) SMS1145
<b>BODY</b>	Stainless steel 316
<b>SHAFT</b>	Stainless steel 316
<b>SEAL</b>	Carbon/ceramic mechanical, food grade nitrile elastomer
<b>BEARINGS</b>	Twin single row, ball/roller type with stainless steel 316 housing
<b>IMPELLER</b>	3A food grade neoprene
<b>WEIGHT</b>	53lb (24kg)

## 15170 Bulkhead/Milk Tanker Pump



### FEATURES

- Flow rate up to 90 GPM (397 LPM)
- Self-priming from dry up to 7.8' (2.4m)
- Pressure up to 21.7 psi (1.5 bar)
- Handles soft solids - 0.7" (18mm) maximum diameter
- Certified to US 3A standard 02-11
- Clean-in-place (CIP) or easy strip clean
- Minimal shear to thixotropic fluids
- Easy to service and maintain

### SPECIFICATIONS

<b>PORTS</b>	2" (51mm) ACME threads or 2" (51mm) tri-clamp
<b>BODY</b>	Stainless steel 316
<b>SHAFT</b>	Stainless steel 316
<b>SEAL</b>	Carbon/ceramic mechanical type, food grade nitrile elastomer
<b>BEARINGS</b>	Twin single row, ball type with stainless steel 316 housing
<b>IMPELLER</b>	3A food grade neoprene
<b>WEIGHT</b>	34lb (15.4kg)

### MODELS

MODEL #	CE	VOLTAGE	IMPELLER	STYLE
15170-7365	Yes	N/A	Sanitary neoprene	2" (51mm) ACME threads
15170-0015	Yes	N/A	Sanitary neoprene	2" (51mm) clamp



# 04 Flexible Impeller Pumps

MODEL VARIANTS



## 53270 SERIES

MODEL #	CE	VOLTAGE	IMPELLER	STYLE
53270-2011	Yes	N/A	Neoprene	Head kit
53270-2013	Yes	N/A	Nitrile	Head kit

## 18610 BRONZE UTILITY PUMP

MODEL #	CE	VOLTAGE	IMPELLER	STYLE
18610-0001	No	115V AC	Neoprene	ODP motor
18610-0003	No	115V AC	Nitrile	ODP motor
18610-0004	No	115V AC	FKM	ODP motor
18610-0271	No	115V AC	Neoprene	TEFC motor
18610-0273	No	115V AC	Nitrile	TEFC motor
18610-0274	No	115V AC	FKM	TEFC motor

## 11810 BRONZE AC UTILITY PUMP

MODEL #	CE	VOLTAGE	IMPELLER	STYLE
11810-0001	No	115V AC	Neoprene	ODP motor
11810-0003	No	115V AC	Nitrile	ODP motor
11810-0011	No	115V AC	Neoprene	TEFC motor
11810-0013	No	115V AC	Nitrile	TEFC motor

## 2760 BRONZE PEDESTAL PUMP

MODEL #	CE	VOLTAGE	IMPELLER	STYLE
2760-0001	Yes	N/A	Neoprene	Pedestal
2760-0003	Yes	N/A	Nitrile	Pedestal

## 2620 BRONZE PEDESTAL PUMP

MODEL #	CE	VOLTAGE	IMPELLER	STYLE
2620-1101	Yes	N/A	Neoprene	Pedestal
2620-1103	Yes	N/A	Nitrile	Pedestal

## 777 BRONZE PEDESTAL FLEXIBLE IMPELLER PUMP

MODEL #	CE	VOLTAGE	IMPELLER	STYLE
777-0001	Yes	N/A	Neoprene	Pedestal
777-0003	Yes	N/A	Nitrile	Pedestal
777-9001	Yes	N/A	Neoprene	Pedestal
777-9003	Yes	N/A	Nitrile	Pedestal
777-9051	Yes	N/A	Neoprene	Pedestal

## 1673 BRONZE PEDESTAL FLEXIBLE IMPELLER PUMP

MODEL #	CE	VOLTAGE	IMPELLER	STYLE
1673-1001	Yes	N/A	Neoprene	Pedestal
1673-1003	Yes	N/A	Nitrile	Pedestal

## 6400 BRONZE PEDESTAL PUMP

MODEL #	CE	VOLTAGE	IMPELLER	STYLE
6400-0004	Yes	N/A	Neoprene	Pedestal
6400-0008	Yes	N/A	Natural rubber	Pedestal
6400-0051	Yes	N/A	Neoprene	Pedestal

## 18370 BRONZE PEDESTAL PUMP & 52270 SERIES

MODEL #	CE	VOLTAGE	IMPELLER	STYLE
18370-0001	Yes	N/A	Neoprene	Pedestal, bronze
18370-0003	Yes	N/A	Nitrile	Pedestal, bronze
52270-2011	Yes	N/A	Neoprene	Pedestal, bronze
52270-2003	Yes	N/A	Nitrile	Pedestal, bronze
52270-0011	Yes	N/A	Neoprene	Pedestal, bronze
52270-0003	Yes	N/A	Nitrile	Pedestal, bronze

## 51510 & 51520 SERIES

MODEL #	CE	VOLTAGE	IMPELLER	STYLE
51510-2001	Yes	N/A	Neoprene	Pedestal, bronze
51510-9001	Yes	N/A	Neoprene	Pedestal, bronze
51520-2001	Yes	N/A	Neoprene	Pedestal, bronze
51520-9001	Yes	N/A	Neoprene	Pedestal, bronze

## 52040 & 52580 SERIES

MODEL #	CE	VOLTAGE	IMPELLER	STYLE
52040-2001	Yes	N/A	Neoprene	Pedestal, bronze
52040-2003	Yes	N/A	Neoprene	Pedestal, bronze
52040-2021	Yes	N/A	Neoprene	Pedestal, bronze
52580-2001	Yes	N/A	Neoprene	Pedestal, bronze
52580-2003	Yes	N/A	Nitrile	Pedestal, bronze
52580-2021	Yes	N/A	Neoprene	Pedestal, bronze
52580-9001	Yes	N/A	Neoprene	Pedestal, bronze
52580-9003	Yes	N/A	Nitrile	Pedestal, bronze
52580-9021	Yes	N/A	Neoprene	Pedestal, bronze

## 52200 & 52220 SERIES

MODEL #	CE	VOLTAGE	IMPELLER	STYLE
52200-2011	Yes	N/A	Neoprene	Pedestal, bronze
52200-2003	Yes	N/A	Nitrile	Pedestal, bronze
52200-2021	Yes	N/A	Neoprene	Pedestal, bronze
52220-2011	Yes	N/A	Neoprene	Pedestal, bronze
52220-2003	Yes	N/A	Nitrile	Pedestal, bronze
52220-2021	Yes	N/A	Neoprene	Pedestal, bronze

## 11860 & 11870 SERIES

MODEL #	CE	VOLTAGE	IMPELLER	STYLE
11860-0005	Yes	12V DC	Neoprene	Pedestal, clutch
11860-0006	Yes	24V DC	Neoprene	Pedestal, clutch
11860-0045	Yes	12V DC	Neoprene	Pedestal, clutch
11860-0051	Yes	24V DC	Neoprene	Pedestal, clutch
11870-0005	Yes	12V DC	Neoprene	Pedestal, clutch
11870-0006	Yes	24V DC	Neoprene	Pedestal, clutch
11870-0045	Yes	12V DC	Neoprene	Pedestal, clutch
11870-0046	Yes	24V DC	Neoprene	Pedestal, clutch

## 50580 SERIES

MODEL #	CE	VOLTAGE	IMPELLER	STYLE
50580-2001	Yes	12V DC	Nitrile	Clutch, bronze
50580-2101	Yes	24V DC	Nitrile	Clutch, bronze
50580-2201	Yes	12V DC	Nitrile	Clutch, bronze
50580-2301	Yes	24V DC	Nitrile	Clutch, bronze
50580-9001	Yes	12V DC	Nitrile	Clutch, bronze
50580-9101	Yes	24V DC	Nitrile	Clutch, bronze
50580-9201	Yes	12V DC	Nitrile	Clutch, bronze
50580-9301	Yes	24V DC	Nitrile	Clutch, bronze

## 50200 & 50220 SERIES

MODEL #	CE	VOLTAGE	IMPELLER	STYLE
50200-2011	Yes	12V DC	Nitrile	Clutch, bronze
50200-2111	Yes	24V DC	Nitrile	Clutch, bronze
50200-2211	Yes	12V DC	Nitrile	Clutch, bronze
50200-2311	Yes	24V DC	Nitrile	Clutch, bronze
50220-0011	Yes	12V DC	Nitrile	Clutch, bronze
50220-0111	Yes	24V DC	Nitrile	Clutch, bronze
50220-0211	Yes	12V DC	Nitrile	Clutch, bronze
50220-0311	Yes	24V DC	Nitrile	Clutch, bronze

## 18330 & 50270 SERIES

MODEL #	CE	VOLTAGE	IMPELLER	STYLE
18330-0000	Yes	12V DC	Nitrile	Clutch, bronze
18330-0001	Yes	24V DC	Nitrile	Clutch, bronze
18330-0040	Yes	12V DC	Nitrile	Clutch, bronze
18330-0041	Yes	24V DC	Nitrile	Clutch, bronze
50270-0011	Yes	12V DC	Nitrile	Clutch, bronze
50270-0311	Yes	24V DC	Nitrile	Clutch, bronze
50270-0211	Yes	12V DC	Nitrile	Clutch, bronze
50270-0031	Yes	24V DC	Nitrile	Clutch, bronze
50270-2011	Yes	12V DC	Nitrile	Clutch, bronze
50270-2111	Yes	24V DC	Nitrile	Clutch, bronze
50270-2211	Yes	12V DC	Nitrile	Clutch, bronze
50270-2311	Yes	24V DC	Nitrile	Clutch, bronze

For the full range of Jabsco pumps series variants, including 305 series, please contact a sales representative.

# 04 Flexible Impeller Pumps

IMPELLER REPLACEMENT GUIDE



## Flexible Impeller Compounds

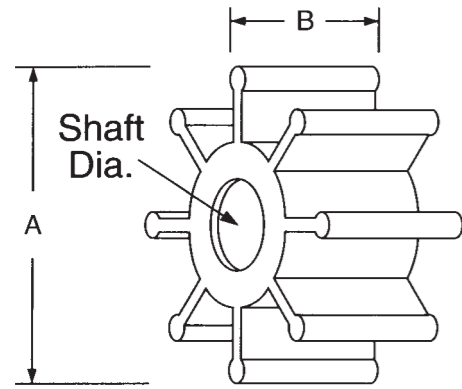

- 1 SLOTTED SHAFT PIN DRIVE
- 2 THROUGH HOLE PIN DRIVE
- 3 KEY DRIVE
- 4 SINGLE FLAT DRIVE
- 5 DOUBLE FLAT DRIVE
- 6 DING DRIVE KEYWAY
- 7 SPLINE DRIVE
- 8 RIBBED SEGMENT KEY

Jabco flexible impellers are available in the following materials:

- Neoprene is the standard impeller material used in most flexible impeller pumps. It offers a wide range of chemical-resistant properties. Temperature range: see product specification chart.
- Nitrile impellers offer compatibility with oil products. It handles a wide range of oils, oil and water emulsions, diesel fuel, lower-fraction hydrocarbons, kerosene, and lubricating and machine-cutting oil. Lower temperatures affect priming ability and performance characteristics. Generally, nitrile performance is 10 percent below that of neoprene. Temperature range: 50°F (10°C) to 180°F (82.2°C).
- FKM impellers are recommended when pumping hydrocarbons, solvents and severely corrosive chemicals. FKM is not recommended for low-temperature or high-pressure applications. Temperature range: 60°F (15.6°C) to 180°F (82.2°C).
- Sanitary neoprene impellers are used in hygienic flexible impeller pumps for applications such as pumping food, beverage and pharmaceutical products. Temperature range: 45°F (7.2°C) to 165°F (73.9°C).
- Natural rubber impellers are used in cold-water applications. Temperature range: 22°F (-5.6°C) to 120°F (48.9°C).
- Sanitary EPDM impellers are used for elevated-temperature, hygienic applications up to 185°F (85°C). EPDM is compatible with some ketone solvents. Temperature range: 60°F (15.6°C) to 185°F (85°C).

## Flexible Impeller Cross-Reference

IMPELLER #	SILHOUETTE	IMPELLER #	SILHOUETTE	IMPELLER #	SILHOUETTE	IMPELLER #	SILHOUETTE	IMPELLER #	SILHOUETTE
4527-0001	G	6760-0003	O	8980-0005	L	14282-0003	M	17370-0001	Q
-0003	G	7273-0001	G	8981-0002	M	-0004	M	17486-0001	H
4528-0001	D	-0003	G	-0005	M	14346-0002	Q	17935-0001	Q
-0003	D	-0004	G	8983-0002	P	-0003	Q	17936-0001	Q
4568-0001	K	7614-0002	K	-0003	P	-0004	Q	17937-0001	Y
-0003	K	-0005	K	-0004	P	-0005	Q	17956-0001	Y
4598-0001	M	8500-0005	AA	-0005	P	14609-0001	C	18018-0001	O
-003	K	8600-0002	V	8984-0005	R	-0003	C	18673-0001	I
5606-0001	G	-0003	V	9200-0001	F	14750-0001	B	-0003	I
-0003	G	-0005	V	-0003	F	-0003	B	18786-0001	R
-0004	G	8713-0005	U	-0021	F	14787-0001	C	-0003	R
5616-0001	G	8840-0002	N	-0023	F	-0003	C	18815-0001	L
5915-0001	N	-0004	N	11979-0001	M	14792-0001	A	18838-0001	W
5929-0001	K	-0005	N	12104-0001	A	-0003	A	18948-0001	X
-0003	K	-0006	N	12326-0001	M	14868-0001	M	21899-0005	U
6056-0003	M	8963-0002	S	-0003	M	14874-0001	I	22120-0001	K
6174-0001	K	-0005	S	14281-0001	K	-0003	I		
-0003	K	8980-0002	L	-0003	K	-0004	I		
6303-0001	H	-0003	L	-0004	K	17255-0003	D		
-0003	H	-0004	L	14282-0001	M	17273-0004	I		

IMPELLER #	MATERIALS	DRIVE TYPE	# OF BLADES	DIMENSIONS		SHAFT DIAMETER	INSERT MATERIALS	REMARKS
				A	B			

### SILHOUETTE A

1414-0001	Neoprene	4	6	1-1/4" (32mm)	0.47" (12mm)	5/16" (8mm)	BR	
-0003	Nitrile	4	6	1-1/4" (32mm)	0.47" (12mm)	5/16" (8mm)	BR	
12104-0001	Neoprene	2	6	1-1/4" (32mm)	0.47" (12mm)	5/16" (8mm)	BR	Onan (use 6-32 x 5/8 HDL's screw)
14792-0001	Neoprene	4	6	1-1/4" (32mm)	0.47" (12mm)	5/16" (8mm)	SS	
-0003	Nitrile	4	6	1-1/4" (32mm)	0.47" (12mm)	5/16" (8mm)	SS	

### SILHOUETTE B

14750-0001	Neoprene	4	8	1-1/4" (32mm)	0.47" (12mm)	5/16" (8mm)	BR	
-0003	Nitrile	4	8	1-1/4" (32mm)	0.47" (12mm)	5/16" (8mm)	BR	

### SILHOUETTE C

14609-0001	Neoprene	4	6	1-1/4" (32mm)	0.47" (12mm)	5/16" (8mm)	BR	
-0003	Nitrile	4	6	1-1/4" (32mm)	0.47" (12mm)	5/16" (8mm)	BR	
14787-0001	Neoprene	4	6	1-1/4" (32mm)	0.47" (12mm)	5/16" (8mm)	PL	
-0003	Nitrile	4	6	1-1/4" (32mm)	0.47" (12mm)	5/16" (8mm)	PL	

### SILHOUETTE D

4528-0001	Neoprene	1 or 2	6	1.6" (40mm)	1/4" (6mm)	3/8" (10mm)	BR	Was AL - 24
-0003	Nitrile	1 or 2	6	1.6" (40mm)	1/4" (6mm)	3/8" (10mm)	BR	Was AL - 24, 37
17255-0003	Nitrile	N/A	6	1.6" (40mm)	1/4" (6mm)	1/4" (6mm)		Impeller molded on shaft

### SILHOUETTE F

9200-0001	Neoprene	4	10	1.6" (40mm)	1/4" (6mm)	5/16" (8mm)	PL	Was brass insert
-0003	Nitrile	4	10	1.6" (40mm)	1/4" (6mm)	5/16" (8mm)	PL	Was brass insert
-0021	Neoprene	4	10	1.6" (40mm)	1/4" (6mm)	5/16" (8mm)	BR	
-0023	Nitrile	4	10	1.6" (40mm)	1/4" (6mm)	5/16" (8mm)	BR	

### SILHOUETTE G

1133-0001	Neoprene	1 or 2	6	2" (51mm)	7/8" (22mm)	1/4" (6mm)	SS	
-0003	Nitrile	1 or 2	6	2" (51mm)	7/8" (22mm)	1/4" (6mm)	SS	
3398-0001	Neoprene	2	6	2" (51mm)	7/8" (22mm)	1/4" (6mm)	None	
-0003	Nitrile	2	6	2" (51mm)	7/8" (22mm)	1/4" (6mm)	None	
-0004	FKM	2	6	2" (51mm)	7/8" (22mm)	1/4" (6mm)	None	
4527-0001	Neoprene	2	6	2" (51mm)	7/8" (22mm)	5/16" (8mm)	None	
-0003	Nitrile	2	6	2" (51mm)	7/8" (22mm)	5/16" (8mm)	None	
5606-0001	Neoprene	6	6	2" (51mm)	7/8" (22mm)	1/4" (6mm)	SS	SS extended drive cup
-0003	Nitrile	6	6	2" (51mm)	7/8" (22mm)	1/4" (6mm)	SS	SS extended drive cup
-0004	FKM	6	6	2" (51mm)	7/8" (22mm)	1/4" (6mm)	SS	SS extended drive cup
5616-0001	Neoprene	6	6	2" (51mm)	7/8" (22mm)	1/4" (6mm)	BR	Brass extended drive cup
7273-0001	Neoprene	4	6	2" (51mm)	7/8" (22mm)	5/16" (8mm)	PL	
-0003	Nitrile	4	6	2" (51mm)	7/8" (22mm)	5/16" (8mm)	PL	

### SILHOUETTE H

6303-0001	Neoprene	4	6	2" (51mm)	7/8" (22mm)	5/16" (8mm)	PL	
-0003	Nitrile	4	6	2" (51mm)	7/8" (22mm)	5/16" (8mm)	PL	
17486-0001	Neoprene	6	6	2" (51mm)	7/8" (22mm)	1/4" (6mm)	BR	Brass extended drive cup

INSERT MATERIALS: BR = Bronze SS = Stainless Steel PL = Epoxy Plastic

# 04 Flexible Impeller Pumps

## IMPELLER REPLACEMENT GUIDE



IMPELLER #	MATERIALS	DRIVE TYPE	# OF BLADES	DIMENSIONS		SHAFT DIAMETER	INSERT MATERIALS	REMARKS
				A	B			

### SILHOUETTE I

14874-0001	Neoprene	5	10	2" (51mm)	7/8" (22mm)	5/8" (16mm)	PL	
-0003	Nitrile	5	10	2" (51mm)	7/8" (22mm)	5/8" (16mm)	PL	
-0004	FKM	5	10	2" (51mm)	7/8" (22mm)	1/4" (6mm)	PL	
17273-0004	FKM	4	10	2" (51mm)	7/8" (22mm)	5/16" (8mm)	PL	
18673-0001	Neoprene	1 or 2	10	2" (51mm)	7/8" (22mm)	1/4" (6mm)	PL	Replaces 673-0001
-0003	Nitrile	1 or 2	10	2" (51mm)	7/8" (22mm)	1/4" (6mm)	PL	Replaces 673-0003

### SILHOUETTE K

1210-0001	Neoprene	7	12	2-1/4" (57mm)	1-1/4" (32mm)	5/8" (16mm)	BR	
-0003	Nitrile	7	12	2-1/4" (57mm)	1-1/4" (32mm)	5/8" (16mm)	BR	
4568-0001	Neoprene	3	12	2-1/4" (57mm)	1-1/4" (32mm)	5/8" (16mm)	BR	
-0003	Nitrile	3	12	2-1/4" (57mm)	1-1/4" (32mm)	5/8" (16mm)	BR	
5929-0001	Neoprene	6	12	2-1/4" (57mm)	1-1/4" (32mm)	1/4" (6mm)	BR	SS drive cup
-0003	Nitrile	6	12	2-1/4" (57mm)	1-1/4" (32mm)	1/4" (6mm)	BR	SS drive cup
6174-0001	Nitrile	6	12	2-1/4" (57mm)	1-1/4" (32mm)	5/8" (16mm)	SS	SS drive cup
-0003	Nitrile	6	12	2-1/4" (57mm)	1-1/4" (32mm)	5/8" (16mm)	SS	SS drive cup
7614-0002	EPDM	5	12	2-1/4" (57mm)	1-1/4" (32mm)	5/8" (16mm)	PL	Sanitary
-0005	Neoprene	5	12	2-1/4" (57mm)	1-1/4" (32mm)	5/8" (16mm)	PL	Sanitary
14281-0001	Neoprene	5	12	2-1/4" (57mm)	1-1/4" (32mm)	5/8" (16mm)	PL	
-0003	Nitrile	5	12	2-1/4" (57mm)	1-1/4" (32mm)	5/8" (16mm)	PL	
-0004	FKM	5	12	2-1/4" (57mm)	1-1/4" (32mm)	5/8" (16mm)	PL	
22120-0001	Neoprene	7	12	2-1/4" (57mm)	2" (51mm)	5/8" (16mm)	BR	

### SILHOUETTE L

3085-0001	Neoprene	7	10	2-1/4" (57mm)	1-1/4" (32mm)	5/8" (16mm)	BR	
8980-0001	Neoprene	5	10	2-1/4" (57mm)	1-1/4" (32mm)	5/8" (16mm)	PL	
-0002	EPDM	5	10	2-1/4" (57mm)	1-1/4" (32mm)	5/8" (16mm)	PL	Sanitary
-0003	Nitrile	5	10	2-1/4" (57mm)	1-1/4" (32mm)	5/8" (16mm)	PL	
-0004	FKM	5	10	2-1/4" (57mm)	1-1/4" (32mm)	5/8" (16mm)	PL	
-0005	Neoprene	5	10	2-1/4" (57mm)	1-1/4" (32mm)	5/8" (16mm)	PL	Sanitary
18815-0001	Neoprene	6	10	2-1/4" (57mm)	1-1/4" (32mm)	1/4" (6mm)	BR	SS drive cup

### SILHOUETTE M

920-0001	Neoprene	7	8	2-9/16" (65mm)	2" (51mm)	5/8" (16mm)	BR	
-0003	Nitrile	7	8	2-9/16" (65mm)	2" (51mm)	5/8" (16mm)	BR	
-0008	Natural rubber	7	8	2-9/16" (65mm)	2" (51mm)	5/8" (16mm)	BR	For temperature range 27°F (-3°C) to 120°F (49°C)
964-0001	Neoprene	7	8	2-9/16" (65mm)	2" (51mm)	5/8" (16mm)	PL	
-0003	Nitrile	7	8	2-9/16" (65mm)	2" (51mm)	5/8" (16mm)	PL	
4598-0001	Neoprene	3	8	2-9/16" (65mm)	2" (51mm)	5/8" (16mm)	BR	
-0003	Nitrile	3	8	2-9/16" (65mm)	2" (51mm)	5/8" (16mm)	BR	
6056-0003	Nitrile	6	8	2-9/16" (65mm)	2" (51mm)	5/8" (16mm)	BR	SS drive cup
8981-0002	EPDM	5	8	2-9/16" (65mm)	2" (51mm)	5/8" (16mm)	PL	Sanitary
-0005	Neoprene	5	8	2-9/16" (65mm)	2" (51mm)	5/8" (16mm)	PL	Sanitary
11979-0001	Neoprene	7	8	2-9/16" (65mm)	1-7/16" (36mm)	5/8" (16mm)	BR	
12326-0001	Neoprene	6	8	2-9/16" (65mm)	2" (51mm)	5/8" (16mm)	SS	SS drive cup
-0003	Nitrile	6	8	2-9/16" (65mm)	2" (51mm)	5/8" (16mm)	SS	SS drive cup
14282-0001	Neoprene	5	8	2-9/16" (65mm)	2" (51mm)	5/8" (16mm)	PL	
-0003	Nitrile	5	8	2-9/16" (65mm)	2" (51mm)	5/8" (16mm)	PL	
-0004	FKM	5	8	2-9/16" (65mm)	2" (51mm)	5/8" (16mm)	PL	

IMPELLER #	MATERIALS	DRIVE TYPE	# OF BLADES	DIMENSIONS		SHAFT DIAMETER	INSERT MATERIALS	REMARKS
				A	B			

### SILHOUETTE N

5915-0001	Neoprene	7	8	2-9/16" (65mm)	2" (51mm)	5/8" (16mm)	BR	
8840-0002	EPDM	5	8	2-9/16" (65mm)	2" (51mm)	5/8" (16mm)	PL	Sanitary
-0003	Nitrile	5	8	2-9/16" (65mm)	2" (51mm)	5/8" (16mm)	PL	
-0004	FKM	5	8	2-9/16" (65mm)	2" (51mm)	5/8" (16mm)	PL	
-0005	Neoprene	5	8	2-9/16" (65mm)	2" (51mm)	5/8" (16mm)	PL	Sanitary

### SILHOUETTE O

331-0001	Neoprene	7	9	3-1/4" (83mm)	2-1/4" (57mm)	1" (25mm)	PL	
836-0001	Neoprene	7	9	3-1/4" (83mm)	2-1/4" (57mm)	1" (25mm)	BR	
-0003	Nitrile	7	9	3-1/4" (83mm)	2-1/4" (57mm)	1" (25mm)	BR	
-0008	Natural rubber	7	9	3-1/4" (83mm)	2-1/4" (57mm)	1" (25mm)	BR	
6760-0003	Nitrile	7	9	3-1/4" (83mm)	3-1/4" (83mm)	1" (25mm)	BR	
18018-0001	Neoprene	7	9	3-1/4" (83mm)	3-1/4" (83mm)	1" (25mm)	SS	SS inserted 331-0001

### SILHOUETTE P

8983-0003	Nitrile	5	10	3-1/4" (83mm)	2-1/4" (57mm)	1" (25mm)	PL	
-0004	FKM	5	10	3-1/4" (83mm)	2-1/4" (57mm)	1" (25mm)	PL	
-0005	Neoprene	5	10	3-1/4" (83mm)	2-1/4" (57mm)	1" (25mm)	PL	Sanitary

### SILHOUETTE Q

14346-0002	EPDM	5	12	3-1/4" (83mm)	2-1/4" (57mm)	1" (25mm)	PL	Sanitary
-0003	Nitrile	5	12	3-1/4" (83mm)	2-1/4" (57mm)	1" (25mm)	PL	
-0004	FKM	5	12	3-1/4" (83mm)	2-1/4" (57mm)	1" (25mm)	PL	
-0005	Neoprene	5	12	3-1/4" (83mm)	2-1/4" (57mm)	1" (25mm)	PL	Sanitary
17370-0001	Neoprene	5	12	3-1/4" (83mm)	3-1/4" (83mm)	1" (25mm)	PL	
17935-0001	Neoprene	7	12	3-1/4" (83mm)	2-1/4" (57mm)	1" (25mm)	BR	
17936-0001	Neoprene	7	12	3-1/4" (83mm)	3-1/4" (83mm)	1" (25mm)	BR	

### SILHOUETTE R

8984-0005	Neoprene	5	9	4-5/8" (117mm)	3-1/4" (83mm)	1" (25mm)	PL	Sanitary
18786-0001	Neoprene	5	9	4-5/8" (117mm)	3-1/4" (83mm)	1" (25mm)	PL	
-0003	Nitrile	5	9	4-5/8" (117mm)	3-1/4" (83mm)	1" (25mm)	PL	
-0004	FKM	5	9	4-5/8" (117mm)	3-1/4" (83mm)	1" (25mm)	PL	

### SILHOUETTE S

8963-0002	EPDM	5	9	4-5/8" (117mm)	3-1/4" (83mm)	1" (25mm)	PL	Sanitary
-0005	Neoprene	5	9	4-5/8" (117mm)	3-1/4" (83mm)	1" (25mm)	PL	Sanitary

### SILHOUETTE U

2999-0001	Neoprene	7	13	5" (127mm)	4" (102mm)	1-1/4" (32mm)	BR	
21899-0005	Neoprene	5	13	5" (127mm)	4" (102mm)	1-1/4" (32mm)	PL	Sanitary
8713-0005	Neoprene	5	13	5" (127mm)	5-1/4" (133)	1-1/4" (32mm)	PL	Sanitary

INSERT MATERIALS: BR = Bronze SS = Stainless Steel PL = Epoxy Plastic

# 04 Flexible Impeller Pumps

IMPELLER REPLACEMENT GUIDE



IMPELLER #	MATERIALS	DRIVE TYPE	# OF BLADES	DIMENSIONS		SHAFT DIAMETER	INSERT MATERIALS	REMARKS
				A	B			
<b>SILHOUETTE V</b>								
8600-0003	Nitrile	5	12	4-5/8" (117mm)	3-1/4" (83mm)	1" (25mm)	PL	
-0005	Neoprene	5	12	4-5/8" (117mm)	3-1/4" (83mm)	1" (25mm)	PL	Sanitary
<b>SILHOUETTE W</b>								
18838-0001	Neoprene	3	12	2-7/16" (62mm)	1-1/4" (32mm)	5/8" (16mm)	BR	
<b>SILHOUETTE X</b>								
18948-0001	Neoprene	3	12	2-9/16" (65mm)	1-5/8" (41mm)	5/8" (16mm)	BR	
<b>SILHOUETTE Y</b>								
17937-0001	Neoprene	7	10	2-9/16" (65mm)	2" (51mm)	5/8" (16mm)	BR	
17956-0001	Neoprene	6	10	2-9/16" (65mm)	2" (51mm)	5/8" (16mm)	BR	SS drive cup, replaces 6056-0001
17981-0005	Neoprene	5	10	2-9/16" (65mm)	2" (51mm)	5/8" (16mm)	PL	Sanitary
<b>SILHOUETTE AA</b>								
8500-0005	Neoprene	5	12	5" (127mm)	4" (102mm)	1-1/4" (32mm)	PL	Sanitary

INSERT MATERIALS: BR = Bronze SS = Stainless Steel PL = Epoxy Plastic

## Flexible Impeller Actual-Size Reference

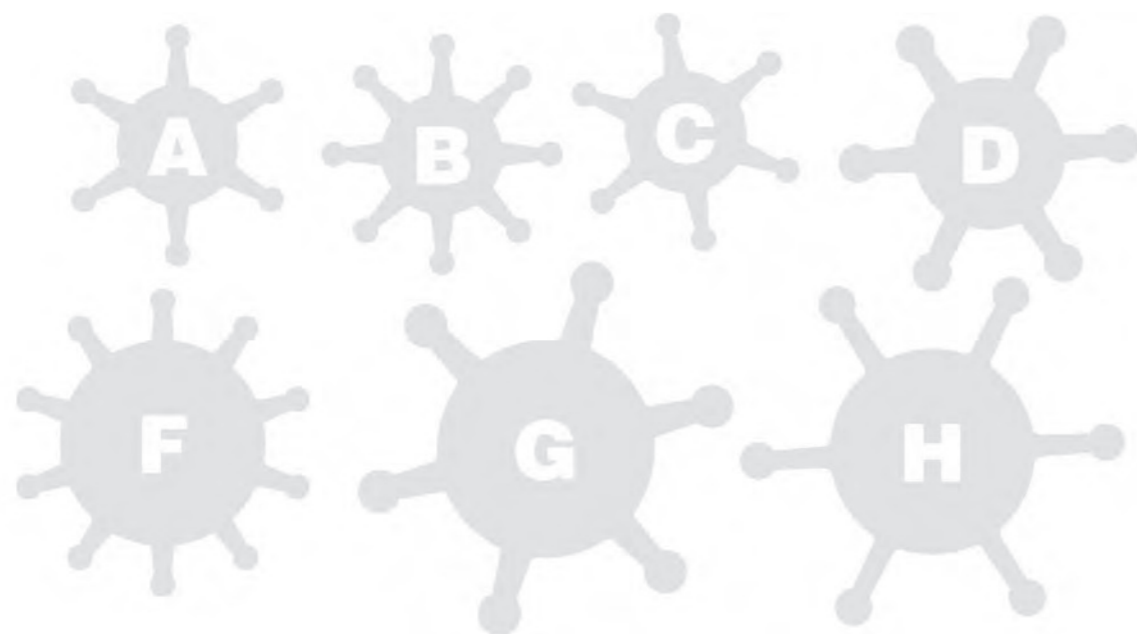
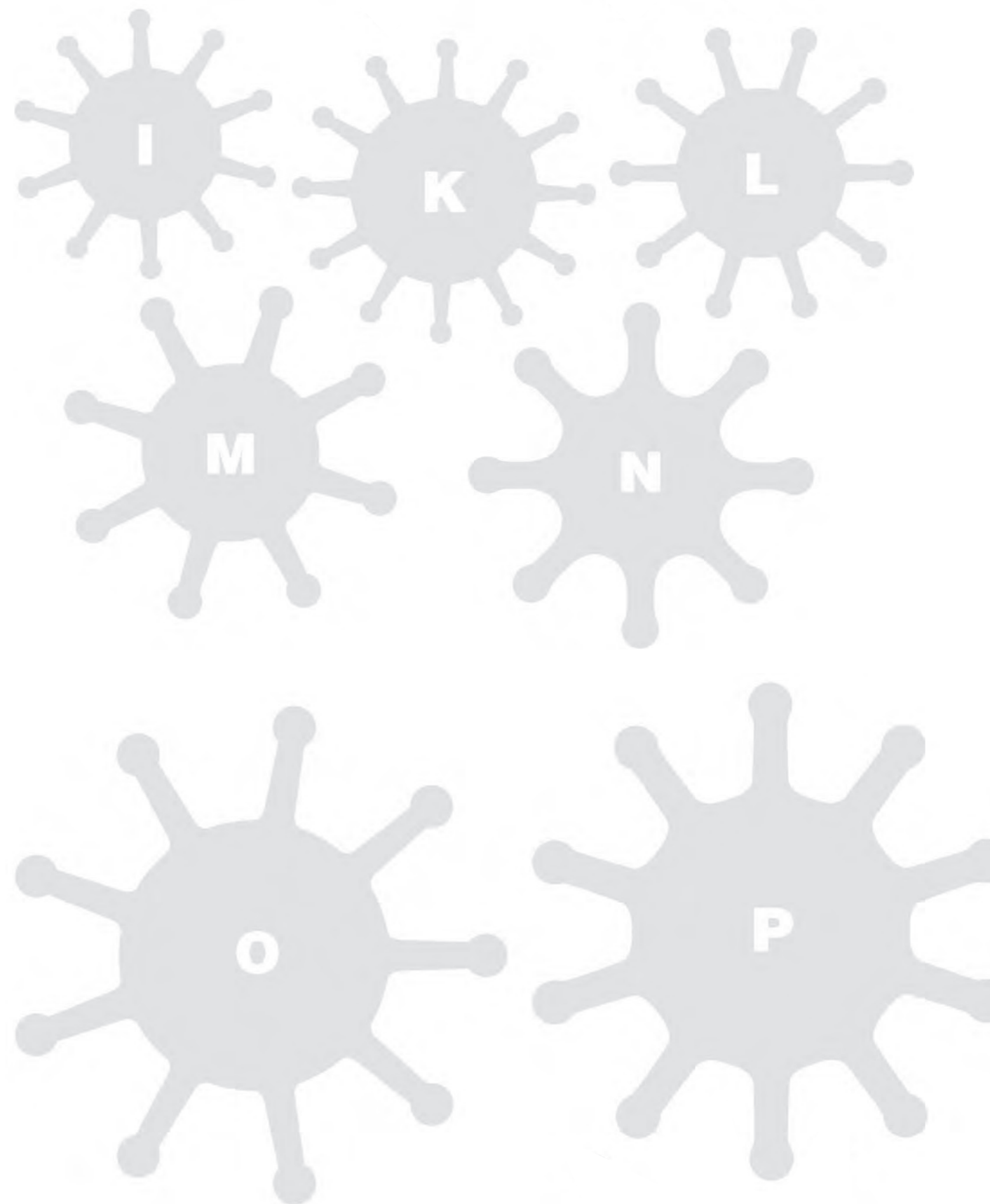

# 04 Flexible Impeller Pumps

IMPELLER REPLACEMENT GUIDE



## Flexible Impeller Actual-Size Reference

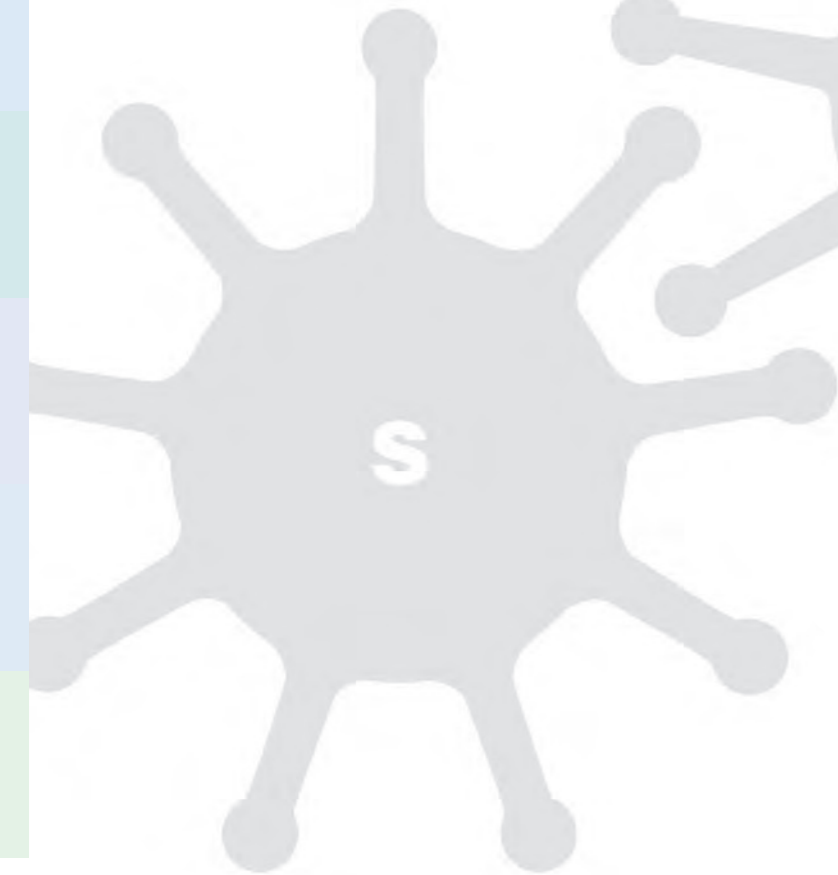

# Hand Pumps 05

Portable & Manual



# 05 Hand Pumps

PORTABLE & MANUAL



## Amazon Warrior



### FEATURES

- Robust design particularly suited to work sites or any installation where heavy-duty use is anticipated
- 18" (457mm) stainless steel handle assists sustained high outputs of up to 35 GPM (135 LPM)
- Double diaphragm design gives maximum efficiency and added safety
- 1-1/2" (38mm) ports give large-solids-handling ability
- Can function on one diaphragm in an emergency
- Epoxy-coated aluminum housing
- Self-priming up to 20' (6m)

### SPECIFICATIONS

MODEL 29280-0000	
<b>BODY</b>	Epoxy-painted alloy
<b>ELASTOMERS</b>	Nitrile
<b>PORTS</b>	1-1/2" (38mm) hose barb

## Portable Pumps



### FOR INDUSTRIAL MARKETS

Constructed of sturdy ABS plastic with comfort-grip handle, providing smooth, firm strokes. Available in 24" (610mm) with hose and 48" (1220mm) with hose.

### SPECIFICATIONS

	MODEL 165	MODEL 168
<b>CAPACITY</b>	8 GPM (30 LPM)	10 GPM (38 LPM)
<b>HOSE SIZE ID</b>	1-1/8" (29mm)	1-1/8" (29mm)
<b>DIMENSIONS</b>	24" (610mm) with 2' (0.6m) of 1-1/8" (29mm) hose	48" (1220mm) with 4' (1.2m) of 1-1/8" (29mm) hose

### MODELS

MODEL #	CE	POWER	OPTIONS
165	Yes	8 GPM (30 LPM)	24" (610mm) hose
168	Yes	10 GPM (38 LPM)	48" (1220mm) hose

## Manual Operated Hand Pumps



### FOR INDUSTRIAL MARKETS

Ultimate heavy-duty hand pump for utility and emergency uses. Made with long-life brass cylinders, high-quality oil-resistant plungers, and impact-absorbing end caps. Units are supplied with varying lengths of hose.

### FEATURES

- Drain, fill or top off engine and gearbox oil
- Overcomes problem of hard-to-reach drain plugs and filler caps

### SPECIFICATIONS

	MODEL 34060-0010	MODEL 33799-0000	MODEL 33760-0000	MODEL 33745-0000
<b>STROKES PER GALLON</b>	40	26	15	7
<b>CYLINDER DIAMETER</b>	1-1/4" (32mm)	1-1/4" (32mm)	1-1/4" (32mm)	1-3/4" (44mm)
<b>LENGTH</b>	10" (254mm)	12" (305mm)	17" (432mm)	22-1/2" (572mm)
<b>CONNECTION SIZE</b>	1/2" (13mm)	1/2" (13mm)	1/2" (13mm)	1" (25mm)
<b>CERTIFICATIONS</b>	CE	CE	CE	CE
<b>WEIGHT</b>	1lb (0.45kg)	2lb (0.9kg)	2.5lb (1.1kg)	4lb (1.8kg)

# Rotary Lobe Pumps 06

Hygienic Pumps





# 06 Rotary Lobe Pumps

HYGIENIC



## 55 Series Ultra Hygienic Positive Displacement Pump



### FOR ULTRA HYGIENIC MARKETS

The ultimate hygienic rotary positive displacement pump designed without compromise to fulfill even the most critical customer demands in clean-ability, sterilize-ability and bacterial tightness. This 316L stainless steel design uses bi-wing or five-lobe rotor designs specifically utilized to achieve the very lowest shear rate and product degradation characteristics.

### DESIGN FEATURES

Ultimate hygienic standards: Tested and approved to the EHEDG (European Hygienic Equipment Design Group), CIP, SIP and bacterial tightness protocols. Full compliance with 3A sanitary standards 18-03 and 02-10, and utilizes materials that meet the requirements of the FDA title 21, section 177.1550.

Cleaner by design: external rotor retention along with gasket-type joints in place of O-rings reduce the number of potential product entrapment areas. In addition, the shaft seals are pulled forward fully in the product zone, all of which adds up to the ultimate in clean-ability every time.

Low product shearing: The bi-wing and five-lobe rotor designs ensure high volumetric efficiency on low viscosity products, resulting in low shear rates and low product damage.

Rugged design: This pump design utilizes extremely large shaft diameters mounted in high specification taper roller bearings. These give maximum shaft stiffness to ensure no galling, thus maintaining the pump's CIP and SIP capabilities.

### SPECIFICATIONS

<b>MAX SPEED</b>	Model 55210 and 55320 - 1500 RPM Model 55420 - 1000 RPM
<b>MAX PRESSURE</b>	Model 55210 - 203 psi (14 bar) Model 55320 and 55420 - 290 (20 bar)
<b>ELASTOMERS</b>	USP Class VI, EPDM, FKM and PTFE product contact joints all in compounds conforming to the FDA CFR title 21 section 177.1550.
<b>CONNECTIONS</b>	US and European standards including tri-clamp. All pumps available in two different sizes.
<b>LIQUID TEMPERATURE RANGE</b>	-22°F (-30°C) to 284°F (140°C)
<b>SEAL</b>	Front-loaded, single mechanical face-type seals of hygienic design. Materials include carbon and silicon carbide.  Low-pressure flushed seals utilize the same single mechanical seal with an additional housing. A low-pressure flush liquid washes away crystallizing products or liquids which "skin over".  Double mechanical seals utilize all the components from single seals. Used for hazardous, toxic, highly abrasive or sterile products.
<b>VISCOSITY</b>	1-1 million
<b>CERTIFICATIONS</b>	3.1B material certification package. 3A variants with nitrile or EPDM elastomers and port options - tri-clamp, IDF, 3A, DIN11851

### OTHER OPTIONS

Aseptic barrier end cover joints to maintain sterility of product during long cycle times. Electro-polish or high-polish internal surfaces to 0.5µm Ra (20 micro-inc Ra) for minimized cell damage and maximized clean-ability.

### MODELS

MODEL #	DISPLACEMENT	MAX FLOW RATE	PORTS	DIMENSIONS	WEIGHT
55210	0.26 GPR (1 LPR)	4.2 GPM (16 LPM)	1/2" (13mm)	5-1/4" high x 7-1/2" long x 4-1/2" wide (135mm x 191mm x 114mm)	18lb (8kg)
55320	0.77 GPR (2.9 LPR)	11.6 GPM (44 LPM)	3/4" (19mm)	6-1/2" high x 10-1/2" long x 5-3/4" wide (168mm x 264mm x 145mm)	42lb (19kg)
55420	1.77 GPR (6.7 LPR)	17.7 GPM (67 LPM)	1" (25mm)	7-1/2" high x 11-3/4" long x 6.5" wide (191mm x 302mm x 168mm)	57lb (26kg)

### CONSTRUCTION DETAILS

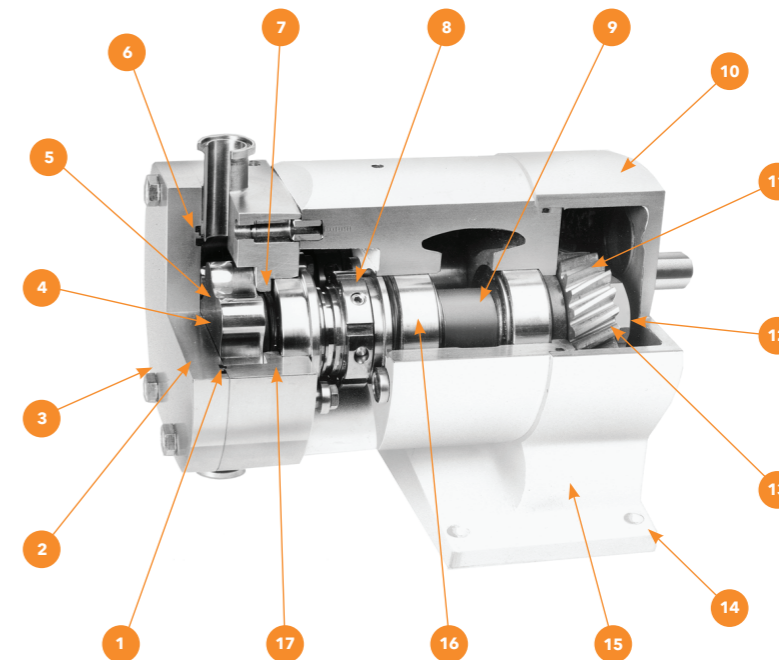

1. Specially modified rotor bores link all areas to port bore to ensure full draining of product
2. Low carbon, stainless steel grade 316L, only 0.03% maximum carbon content, 60% less than conventional pumps
3. High-surface finish fully meets US #A requirements with 240 grit polish and electro-polish options
4. Single key rotor drive is proven to be superior to involute spline. Used in conjunction with high-tech polymer support spigot to eliminate fretting
5. Unique rotor design with improved profile and extended screwed stub shaft to eliminate crevices
6. Gasket-type joints - all pump head components have been specially developed to totally eliminate the crevices associated with traditional O-rings
7. Ultra clean seals have been specially developed to be crevice-free, self-draining and front-loading
8. External rotor retainers eliminate all internal crevices associated with conventional bolts and nuts
9. High strength shafts made from a stainless steel with 230% greater tensile strength than conventional pump shafts
10. Smooth contoured externals with generous drain angle of not less than 2-1/2" and no major crevices
11. Extra wide helical greats up to 8-% wider than normally used. Precision ground to ensure minimal backlash and smooth operation.
12. Single key great drive gives precise positioning of gear and will not slip as some torque brushes can
13. Oil lubricated gears gives optimum lubricant film between meshing gear teeth
14. Multi-position mounting of foot/gear housing with only 4 screws to allow easy change from vertical to horizontal port position
15. Robust bearing carrier manufactured in caustic and solvent resistant, epoxy-coated cast iron
16. Oversize bearings up to 60% greater life than normally achieved. No maintenance required and no contamination from gear lubricant
17. US FDA approved materials in contact with the product throughout

# 06 Rotary Lobe Pumps

HYGIENIC



## HP & UL Series

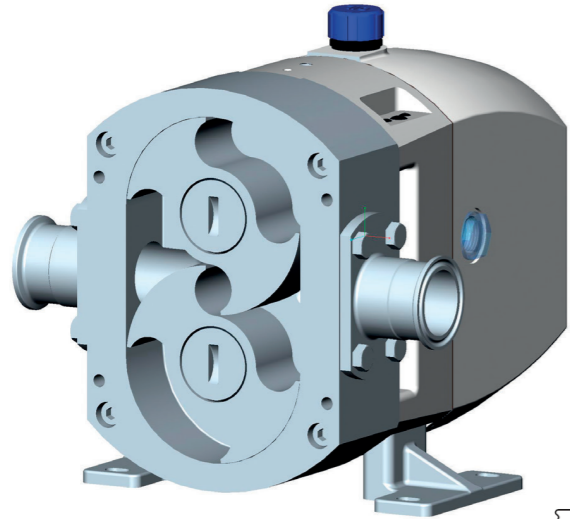

With a proven 50 year heritage in Lobe Pump manufacturing, Jabsco branded lobe pumps are taking the next step in flexibility and value with the Hy-Line+ (HP Series) and Ultra-Line (UL Series).

Combined strengths and experience in one key platform. Jabsco lobe pumps offer high flow, high pressure capabilities from a positive displacement non contacting rotary lobe pump package incorporating a choice of scimitar or tri-lobe rotors. With applications in industry, food, beverage and bio-pharmaceutical processing sectors, Jabsco lobe pumps can be found decanting, transferring, filling, spraying, dosing a wide range of fluids in many varied environments (including ATEX designated zones).

Modular procurement brings flexibility. Modularity is a key feature to both the Hy-Line+ and Ultra-line series. With today's market being driven by lead time, flexibility will allow our supply chain to reduce this factor. The HP and UL series lobe pumps are offered in three key modules; Vertical and horizontal foot kits, port kits and the pump module. The pumps stand on stainless steel feet, redesigned for greater stability and improved durability.

### FEATURES

- Epoxy-coated bearing housing and gear cover; available in stainless steel
- Pump module, feet and port kits sold separately. 1 pump, 96 possible variants, for sizes 4 – 6
- Hopper inlet option
- Nitrile, FKM and PTFE wetted elastomers to FDA, 3A and EN1935:2004; EPDM to USP Class VI
- Front loading seals and rotors as standard across the range
- HP series end cover supports relief valves and end covers
- 304 stainless steel feet as standard on sizes 4 – 7
- Tri-lobe and scimitar rotor options on one pump platform

### APPLICATIONS

- Industrial
- Food and beverage
- Bio-pharmaceutical processing
- Decanting
- Transfer
- Filling
- Spraying

### SPECIFICATIONS

<b>PUMP</b>	High-flow, high-pressure, positive displacement, non-contacting rotary lobe
<b>POWER SOURCE</b>	Shaft coupled, electric motor drive (not provided)
<b>WETTED PARTS</b>	316L with epoxy-coated aluminum gear cover
<b>SEAL*</b>	C/SS, SiC/SiC, single or double with flush; 304 stainless steel mounting feet with nitrile, FKM, EPDM, or PTFE elastomer joints

\* Additional seal information and configurations available. Please contact us if you do not see what you are looking for

### MODELS

PUMP SIZE	MAX SPEED	MAX PRESSURE	MAX FLOW	WEIGHT
32	1500 RPM	217 psi (15 bar)	93 GPM (350 LPM)	22lb (10kg)
34	1500 RPM	116 psi (8 bar)	211 GPM (800 LPM)	27lb (12kg)
42	1000 RPM	217 psi (15 bar)	325 GPM (1,230 LPM)	40lb (18kg)
44	1000 RPM	116 psi (8 bar)	539 GPM (2,040 LPM)	44lb (20kg)
52	1000 RPM	217 psi (15 bar)	700 GPM (2,650 LPM)	70lb (32kg)
54	1000 RPM	116 psi (8 bar)	1,202 GPM (4,550 LPM)	77lb (35kg)
62	720 RPM	217 psi (15 bar)	1,690 GPM (6,400 LPM)	134lb (61kg)
64	720 RPM	116 psi (8 bar)	2,509 GPM (9,500 LPM)	143lb (65kg)
72	680 RPM	217 psi (15 bar)	3,249 GPM (12,300 LPM)	275lb (125kg)
74	600 RPM	116 psi (8 bar)	5,415 GPM (20,500 LPM)	319lb (145kg)
76	600 RPM	72 psi (5 bar)	7,951 GPM (30,100 LPM)	363lb (165kg)

### DIMENSIONS

Unless otherwise stated, dimensions are in inches and (mm).

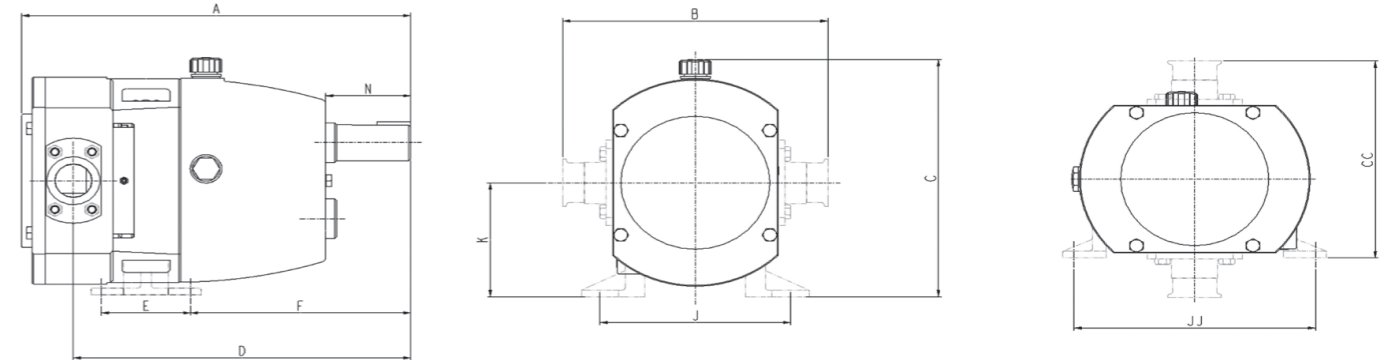

PUMP SIZE	A	B*	C	CC	D	E	F	J	JJ	K	N
32	8.4" (213mm)	7.6" (192mm*)	7.3" (184mm)	7.6" (192mm)	7.2" (183mm)	1.6" (40mm)	4.1" (105mm)	4.3" (110mm)	4.3" (110mm)	3.8" (96mm)	1.4" (36mm)
34	9" (229mm)	7.6" (192mm)	7.3" (184mm)	7.6" (192mm)	7.4" (188mm)	1.6" (40mm)	4.1" (105mm)	4.3" (110mm)	4.3" (110mm)	3.8" (96mm)	1.4" (36mm)
42	10.8" (274mm)	8.8" (223mm)	8.3" (212mm)	7.2" (183mm)	9.1" (231mm)	2.8" (72mm)	5.6" (142mm)	5.9" (150mm)	7.9" (200mm)	3.9" (99mm)	1.7" (42mm)
44	11.4" (290mm)	8.8" (223mm)	8.3" (212mm)	7.2" (183mm)	9.5" (241mm)	2.8" (72mm)	5.6" (142mm)	5.9" (150mm)	7.9" (200mm)	3.9" (99mm)	1.7" (42mm)
52	14.5" (368mm)	9.8" (249mm)	9.8" (250mm)	8.2" (208mm)	12.6" (319mm)	3.3" (84mm)	8.2" (208mm)	7" (178mm)	9" (229mm)	4.7" (120mm)	3.1" (79mm)
54	15.6" (396mm)	10.2" (259mm)	9.8" (250mm)	8.4" (213mm)	13.3" (338mm)	3.3" (84mm)	8.2" (208mm)	7" (178mm)	9" (229mm)	4.7" (120mm)	3.1" (79mm)
62	17" (433mm)	11.3" (288mm)	13" (329mm)	9.8" (249mm)	14.6" (370mm)	4.8" (122mm)	8.8" (224mm)	7.9" (200mm)	11.6" (294mm)	6.9" (174mm)	3.1" (79mm)
64	18.2" (462mm)	11.9" (302mm)	13" (329mm)	10.1" (256mm)	14.9" (379mm)	4.8" (122mm)	8.2" (208mm)	7.9" (200mm)	11.6" (294mm)	6.9" (174mm)	3.1" (79mm)
72	19.3" (489mm)	15" (380mm)	15" (381mm)	12.8" (324mm)	16.3" (414mm)	8.3" (210mm)	7" (178mm)	11.3" (288mm)	13.5" (342mm)	7.3" (186mm)	3.5" (89mm)
74	20.8" (529mm)	15" (380mm)	15" (381mm)	12.8" (324mm)	17.3" (439mm)	8.3" (210mm)	7" (178mm)	11.3" (288mm)	13.5" (342mm)	7.3" (186mm)	3.5" (89mm)
76	22.7" (576mm)	16.2" (411mm)	15" (381mm)	13.4" (340mm)	18" (456mm)	8.3" (210mm)	7" (178mm)	11.3" (288mm)	13.5" (342mm)	7.3" (186mm)	3.5" (89mm)

\* Size 3 has welded ports.  
 1" (25mm) tri-clamp = 6.9" (175mm)  
 1" (25mm) DIN11851 = 7.9" (201mm)  
 1-1/2" (38mm) BSP = 7.9" (201mm)

# Oscillating Pumps 07

Oscillating Pumps



**FLOJET**®

# 07 Oscillating Pumps

OSCILLATING

**FLOJET®**

## PS Series



### FOR COMMERCIAL AND INDUSTRIAL MARKETS

Building on our extensive experience in positive displacement pumps, Flojet's PS Series oscillating pumps provide a compact solution for low-flow, high-pressure applications.

### APPLICATIONS

- Espresso coffee makers
- Medical appliances
- Floor care machines
- Water dispensers
- Steam irons
- Air conditioners
- Steam generators
- Cooling systems
- Steam-cleaning systems

### PERFORMANCE

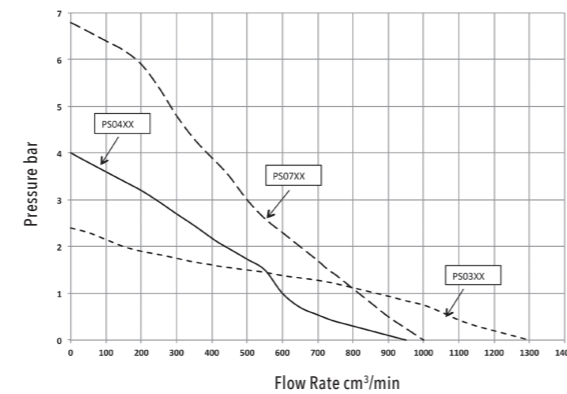
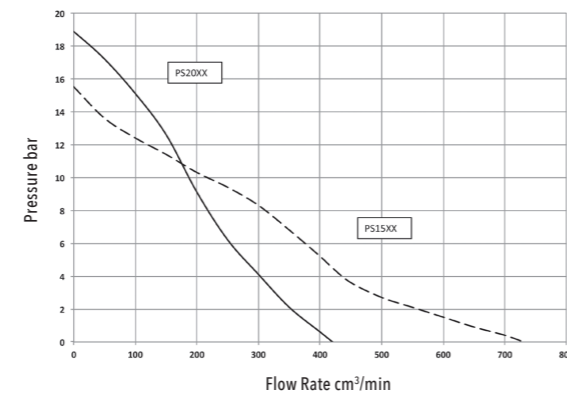

Open flow rate may vary +/- 10 percent depending on installation.

### SPECIFICATIONS

<b>PUMP DESIGN</b>	Oscillating pump
<b>VOLTAGE</b>	Nominal at 110V or 230V AC
<b>MAX FLOW RATE</b>	0.3 GPM (1.2 LPM)
<b>MAX PRESSURE</b>	276 psi (19 bar)
<b>PORTS</b>	Outlet - 1/8" (3mm) BSP (NPT optional) Inlet - 1/4" (6mm) hose barb (BSP and NPT optional)
<b>COIL</b>	Insulation class II/thermal class "F"
<b>BODY</b>	Polyamide (brass optional)
<b>MAX LIQUID TEMPERATURE</b>	95°F (35°C)
<b>SEAL</b>	NBR/HNBR
<b>CERTIFICATIONS</b>	CE, UL, VDE

### DIMENSIONAL DRAWINGS

Unless otherwise stated, dimensions are in inches and (mm).

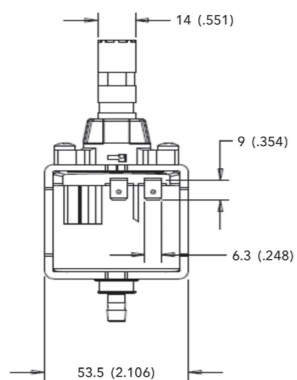
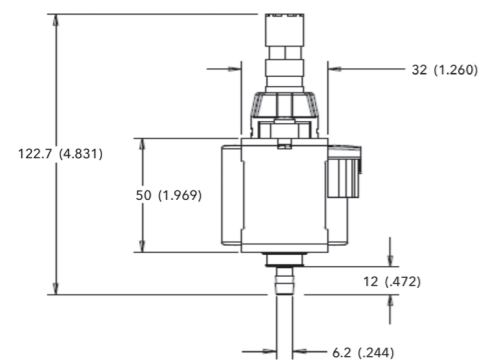

### MODELS

MODEL #	MAX FLOW RATE	MAX PRESSURE	VOLTAGE	FREQUENCY	PORT / ELASTOMER MATERIAL
PS0311	0.3 GPM (1.2 LPM)	44 psi (3 bar)	120V AC	60Hz	NBR
PS0321	0.3 GPM (1.2 LPM)	44 psi (3 bar)	230V AC	50Hz	NBR
PS0411	0.25 GPM (0.95 LPM)	58 psi (4 bar)	120V AC	60Hz	NBR
PS0421	0.25 GPM (0.95 LPM)	58 psi (4 bar)	230V AC	50Hz	NBR
PS0711	0.26 GPM (0.98 LPM)	102 psi (7 bar)	120V AC	60Hz	NBR
PS0721	0.26 GPM (0.98 LPM)	102 psi (7 bar)	230V AC	50Hz	NBR
PS1511	0.17 GPM (0.64 LPM)	218 psi (15 bar)	120V AC	60Hz	NBR
PS1521	0.17 GPM (0.64 LPM)	218 psi (15 bar)	230V AC	50Hz	NBR
PS2011	0.11 GPM (0.42 LPM)	276 psi (19 bar)	120V AC	60Hz	NBR
PS2021	0.11 GPM (0.42 LPM)	276 psi (19 bar)	230V AC	50Hz	NBR

### ACCESSORIES

PART #	DESCRIPTION
PSA0100	Inlet elbow hose adapter
PSA0101	Inlet adapter - 1/8" (3mm)
PSA0200	Rubber pump mount - PVC - < 122°F (50°C)
PSA0201	Rubber pump mount - SEBS - < 212°F (100°C)

# Sliding Vane Pumps 08

Diesel Sliding Vane



# 08 Sliding Vane Pumps

DIESEL SLIDING VANE



## Rotary Vane Pump

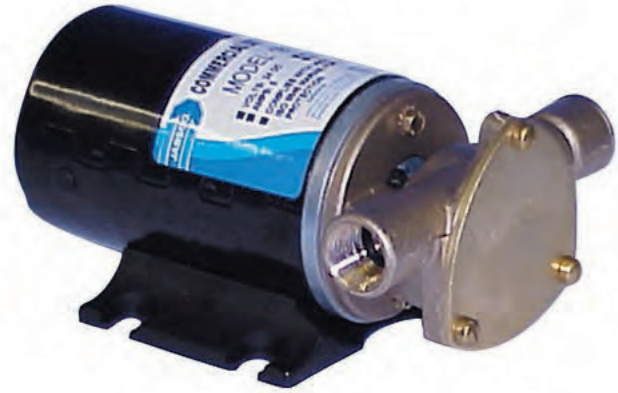

### FOR INTERNATIONAL & US MARKETS

The Jabsco reversible rotary vane pump is ideal for transferring diesel fuel. It is self-priming to about 3' (0.9m) and can pump against a discharge head up to 20' (6m). With its integral on/off reversing switch, it is ideal for moving fuel between port and starboard fuel tanks. Meets USCG 183.410 and ISO8846 MARINE (Ignition Protection).

### MODELS

MODEL #	CE	DESCRIPTION
18680-0920	Yes	6.1 GPM (23 LPM) 12V DC pump 1/2" (13mm) NPT
18680-0940	Yes	6.1 GPM (23 LPM) 24V DC pump 1/2" (13mm) NPT
18680-1000	Yes	6.1 GPM (23 LPM) 12V DC pump 1/2" (13mm) NPT reversible

Note: 18680-1000 is reversible, the other models are not.

### SPECIFICATIONS

<b>PORTS</b>	1/2" (13mm) NPT internal pipe threads 1" (25mm) external hose barb
<b>MOTOR</b>	12V DC permanent magnet type, intermittent duty, fully enclosed
<b>BODY</b>	Bronze
<b>SHAFT</b>	Stainless steel
<b>SEAL</b>	Nitrile lip type
<b>ROTOR</b>	Vectra
<b>VANES</b>	Ryton
<b>DIMENSIONS</b>	3-3/8" high x 8-5/8" long x 4-3/4" wide (86mm x 219mm x 121mm)
<b>WEIGHT</b>	5.5lb (2.5kg)

### DIMENSIONAL DRAWINGS

Unless otherwise stated, dimensions are in inches and (mm).

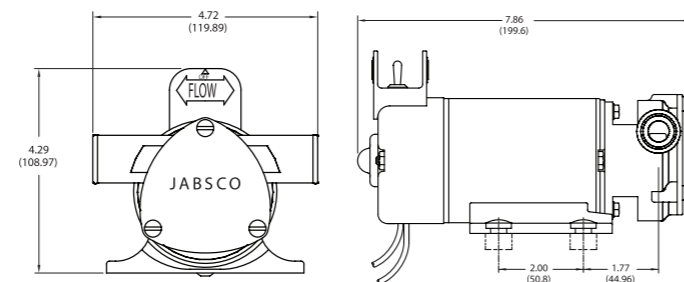

## Sliding Vane VF040

Light-duty diesel pump.

- 10 GPM (38 LPM) at 10' (3m) head
- 22' (7m) maximum total head
- Self-priming up to 9' (2.8m) vertical lift
- 22°F (-30°C) to 104°F (40°C) operating temperature range
- 30 minutes at 10' (3m) at 86°F (30°C)
- IP55 and thermally protected motor
- Integral switch fitted as standard
- Accessories available
- ISO 8846 MARINE (Ignition Protection)



### MODELS

MODEL	DESCRIPTION
VF040-012-6120A	12V DC model, fitted switch
VF040-024-6120A	24V DC model, fitted switch
SK422-0025	Service Kit

### SPECIFICATIONS

<b>FITTING</b>	Connections for 3/4" (19mm) ID hose
<b>SIZE</b>	8" long x 5" wide x 6-1/4" high (20cm x 13cm x 16cm)
<b>WEIGHT</b>	4.4lb (2kg)

## Sliding Vane VF060

Continuously rated, diesel pump.

- 20 GPM (68 LPM) at 10' (3m) total head
- Self-priming up to 9.6' (3m) vertical lift
- Integral switch and ports as standard
- 22°F (-30°C) to 104°F (40°C) operating temperature range
- IP55 and thermally protected motor
- ISO 8846 MARINE (Ignition Protection)



### MODELS

MODEL	DESCRIPTION
VF060-024-6120A	24V DC model, fitted switch, 1" (25mm) ID hose
SK422-0035	Service Kit

### SPECIFICATIONS

<b>FITTING</b>	Connections for 1" (25mm) ID hose
<b>SIZE</b>	8" long x 5" wide x 6-1/4" high (20cm x 13cm x 16cm)
<b>WEIGHT</b>	11lb (5kg)

## Sliding Vane VF100

Heavy-duty, continuously rated diesel pump.

- 29 GPM (110 LPM) at 10' (3m) total head
- Self-priming up to 16' (5m) vertical lift
- 22°F (-30°C) to 104°F (40°C) operating temperature range
- IP55 and thermally protected motor
- ISO 8846 MARINE (Ignition Protection)



### MODELS

MODEL	DESCRIPTION
VF100-024-6120A	24V DC model, fitted switch, 1-1/4" (32mm) ID hose
SK422-0045	Service Kit

### SPECIFICATIONS

<b>FITTING</b>	Connections for 1-1/4" (32mm) ID hose
<b>SIZE</b>	10" long x 5-1/2" wide x 6-3/4" high (25cm x 14cm x 17cm)
<b>WEIGHT</b>	19.8lb (9kg)

# Specialty Products 09

Blowers  
Bottled Water Systems  
Oil Changers





## Flange Mount Blower



### FOR INTERNATIONAL & US MARKETS

Flange mount blowers are mounted with the discharge port fastened directly to a flat surface to minimize ducting. The inlet port can then be connected with duct hose to the area requiring ventilation. Standard models are rated for intermittent service, 15 minutes on and 15 minutes off. Commercial-duty models are rated for continuous service.

### FEATURES

- Tough, reinforced plastic housing
- Mount to any flat surface
- Slip-on inlet ducting connection
- Efficient, high volume air flow
- Low current draw
- Corrosion-resistant materials throughout
- N.M.M.A. type accepted
- Meets USCG Electrical Regulations of Title 33,, chapter I, part 183; subpart I and ISO 8846 MARINE for ignition protection
- DC models comply with ISO 9097 MARINE

### MODELS

MODEL #	CE	AIR FLOW	VOLTAGE	AMPS	FUSE SIZE	INLET	OUTLET	DIMENSIONS	WEIGHT
<b>STANDARD DUTY</b>									
34744-0000	Yes	100 CFM	115V AC	0.7A	0.8A	3" (76mm)	2-3/4" (70mm)	7-5/8" high x 6-5/8" wide x 7" long (193mm x 168mm x 175mm)	5lb (2.3kg)
		47,200 CUCM/sec							
35115-0020	Yes	105 CFM	12V DC	4.4A	6A	3" (76mm)	2-3/4" (70mm)	5-1/2" high x 4-3/4" wide x 6-3/4" long (140mm x 121mm x 171mm)	4lb (1.8kg)
		49,600 CUCM/sec							
34739-0010	Yes	150 CFM	12V DC	6.5A	10A	3" (76mm)	2-3/4" (70mm)	7-5/8" high x 6-5/8" wide x 8" long (193mm x 168mm x 203mm)	5lb (2.3kg)
		70,800 CUCM/sec							
34739-0020	Yes	150 CFM	24V DC	3.3A	5A	3" (76mm)	2-3/4" (70mm)	7-5/8" high x 6-5/8" wide x 8" long (193mm x 168mm x 203mm)	5lb (2.3kg)
		70,800 CUCM/sec							
34739-0031	Yes	140 CFM	115V AC	1A	1.3A	3" (76mm)	2-3/4" (70mm)	7-5/8" high x 6-5/8" wide x 8-3/8" long (193mm x 168mm x 213mm)	5lb (2.3kg)
		66,000 CUCM/sec							
35400-0000	Yes	250 CFM	12V DC	10A	15A	4" (102mm)	3-5/8" (91mm)	9" high x 8-3/4" wide x 8-3/4" long (229mm x 222mm x 222mm)	6lb (2.7kg)
		118,000 CUCM/sec							
35400-0010	Yes	250 CFM	24V DC	5.3A	7.5A	4" (102mm)	3-5/8" (91mm)	9" high x 8-3/4" wide x 8-3/4" long (229mm x 222mm x 222mm)	6lb (2.7kg)
		118,000 CUCM/sec							
<b>COMMERCIAL DUTY</b>									
35760-0092	Yes	250 CFM	12V DC	11A	15A	4" (102mm)	3-5/8" (91mm)	9" high x 9-7/8" wide x 8-3/4" long (229mm x 230mm x 222mm)	6lb (2.7kg)
		118,000 CUCM/sec							
35760-0094	Yes	250 CFM	24V DC	6A	10A	4" (102mm)	3-5/8" (91mm)	9" high x 9-7/8" wide x 8-3/4" long (229mm x 230mm x 222mm)	6lb (2.7kg)
		118,000 CUCM/sec							
36760-0115	Yes	250 CFM	115V AC	1.5A	3A	4" (102mm)	3-5/8" (91mm)	9" high x 9-7/8" wide x 8-3/4" long (229mm x 230mm x 222mm)	9lb (4.1kg)
		118,000 CUCM/sec							

## Flex Mount Blower



### FOR INTERNATIONAL & US MARKETS

Flex mount blowers have both inlet and outlet ports designed for slip-on flexible duct connections. They are ideal when an in-line installation is preferred. The blower may be rotated in the mounting bracket to orient the discharge port in any direction. Standard-duty blowers are rated for intermittent service, 15 minutes on and 15 minutes off. Commercial-duty models are rated for continuous service.

### FEATURES

- Tough, reinforced plastic housing
- Universal flexmount bracket permits outlet to face any direction
- Slip-on inlet ducting connection
- Efficient, high volume air flow
- Low current draw
- Corrosion-resistant materials throughout
- N.M.M.A. type accepted
- Meets USCG Electrical Regulations of Title 33,, chapter I, part 183; subpart I and ISO 8846 MARINE for ignition protection
- DC models comply with ISO 9097 MARINE

### MODELS

MODEL #	CE	AIR FLOW	VOLTAGE	AMPS	FUSE SIZE	INLET	OUTLET	DIMENSIONS	WEIGHT
<b>STANDARD DUTY</b>									
34754-0000	Yes	100 CFM	115V AC	0.7A	0.8A	3" (76mm)	2-3/4" (70mm)	7-5/8" high x 6-5/8" wide x 7" long (193mm x 168mm x 175mm)	5lb (2.3kg)
		47,200 CUCM/sec							
35115-0010	Yes	105 CFM	12V DC	4.3A	6A	3" (76mm)	2-3/4" (70mm)	5-1/2" high x 4-3/4" wide x 6-3/4" long (140mm x 121mm x 171mm)	4lb (1.8kg)
		49,600 CUCM/sec							
36740-0010	Yes	150 CFM	12V DC	6.8A	10A	3" (76mm)	2-3/4" (70mm)	7-5/8" high x 6-5/8" wide x 8" long (193mm x 168mm x 203mm)	5lb (2.3kg)
		70,800 CUCM/sec							
36740-0020	Yes	150 CFM	24V DC	3.3A	5A	3" (76mm)	2-3/4" (70mm)	7-5/8" high x 6-5/8" wide x 8" long (193mm x 168mm x 203mm)	5lb (2.3kg)
		70,800 CUCM/sec							
36740-0031	Yes	140 CFM	115V AC	1A	1.3A	3" (76mm)	2-3/4" (70mm)	7-5/8" high x 6-5/8" wide x 8-3/8" long (193mm x 168mm x 213mm)	5lb (2.3kg)
		66,000 CUCM/sec							
35400-0000	Yes	250 CFM	12V DC	10A	15A	4" (102mm)	3-5/8" (91mm)	9" high x 8-3/4" wide x 8-3/4" long (229mm x 222mm x 222mm)	6lb (2.7kg)
		118,000 CUCM/sec							
35400-0010	Yes	250 CFM	24V DC	5.3A	7.5A	4" (102mm)	3-5/8" (91mm)	9" high x 8-3/4" wide x 8-3/4" long (229mm x 222mm x 222mm)	6lb (2.7kg)
		118,000 CUCM/sec							
<b>COMMERCIAL DUTY</b>									
35770-0092	Yes	250 CFM	12V DC	11A	15A	4" (102mm)	3-5/8" (91mm)	9" high x 9-7/8" wide x 8-3/4" long (229mm x 230mm x 222mm)	6lb (2.7kg)
		118,000 CUCM/sec							
35770-0094	Yes	250 CFM	24V DC	6A	10A	4" (102mm)	3-5/8" (91mm)	9" high x 9-7/8" wide x 8-3/4" long (229mm x 230mm x 222mm)	6lb (2.7kg)
		118,000 CUCM/sec							
36770-0115	Yes	250 CFM	115V AC	1.5A	3A	4" (102mm)	3-5/8" (91mm)	9" high x 9-7/8" wide x 8-3/4" long (229mm x 230mm x 222mm)	9lb (4.1kg)
		118,000 CUCM/sec							





## Rule® In-Line Blowers



### FOR INTERNATIONAL & US MARKETS

Designed for efficient, high-output operation, these blowers feature corrosion-resistant motor housings for long life. Compact and easily installed on any flat surface, Rule® in-line blowers provide higher air flow, lower amp draw, and quieter operation than standard blowers.

These blowers can be run at half voltage (for example, 24V version at 12V) to reduce noise, reduce flow, and greatly extend motor life.

### FEATURES

- Efficient high volume air flow
- Quiet operation with a low amp draw
- Slip-on inlet and outlet ducting connections
- Corrosion-resistant, nickel-plated motor housing
- IMCI (CE)
- Ignition protected

### MODELS

MODEL #	CE	DUCTING	VOLTAGE	CFM AT OPEN FLOW	AMP DRAW	FUSE SIZE
140	Yes	3"(76mm)	13.6V	135	2.9A	4A
140-24V	Yes	3"(76mm)	27.2V	135	1.7A	2.5A
240	Yes	4"(102mm)	13.6V	235	4.3A	7A
240-24V	Yes	4"(102mm)	27.2V	235	2.4A	4A

### DIMENSIONAL DRAWINGS

Unless otherwise stated, dimensions are in inches and (mm).

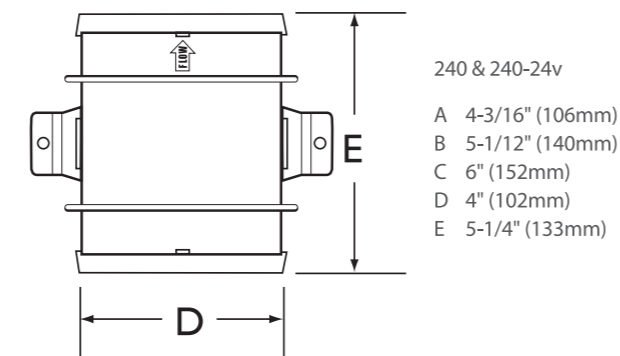
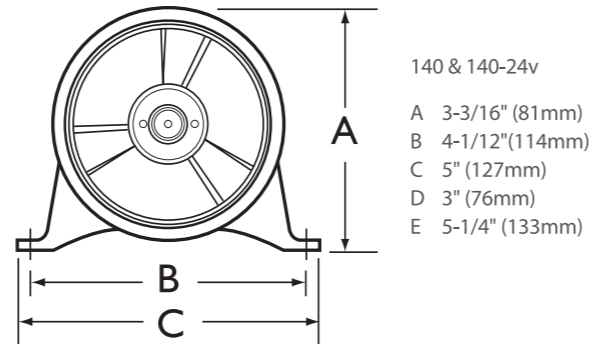

## Bottled Water Solutions for Beverage Dispensing

There are many situations where portable water is needed for a variety of drink dispensers, in locations where filtered water is not available. A good example is a portable coffee station. These are often moved into ideal locations for conferences, meetings or other specific events, but those convenient locations often don't have plumbing for water. Even businesses that want a permanent installation may not want to incur the cost of installing plumbing to the desired location.

A common solution in these situations is to use purified bottled water as the water source for the drink dispenser with a pump to provide pressure. Using purified bottled water has the advantage that no plumbed water is required, and the pump provides constant pressure for beverage dispensers. The pump also eliminates the need to lift the 40+ pound water bottle up high and flip it into a typical water dispenser.

Flojet offers bottled water systems with options to work with 1 or 2 jugs of bottled water at a time. Single inlet models feature one suction wand while the dual inlet modes feature two. Dual inlet models are ideal in high water use situations.

All Flojet bottled water systems shut off automatically when the water source is depleted. When water is restored, the pump automatically restarts. A sealed vacuum keeps water fresh and a built-in check valve prevents back flow. The pump operates quietly and automatically turns on and off when the faucet is opened and closed. Systems are available in 115F and 230V options.

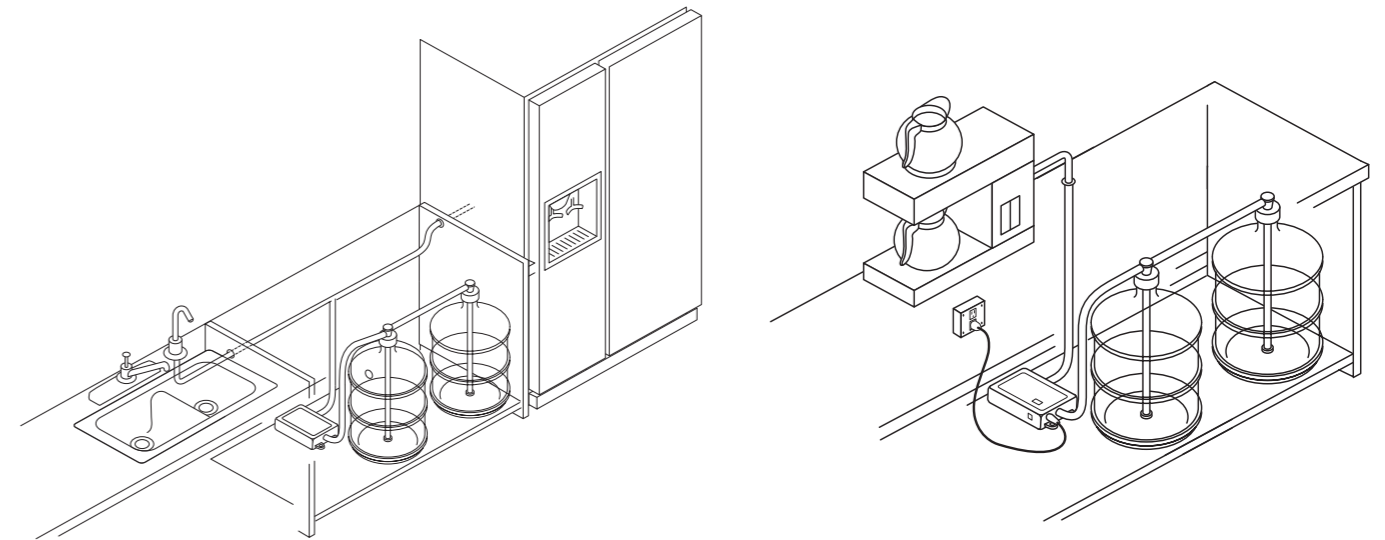

Bottled water products shown on page 162-163.

## 5000 Series Bottle Water System



### FEATURES

- Float switch for automatic shut-off when bottle is empty
- Built-in check valve to prevent back flow
- Universal seal cap
- Easy mounting and installation
- Upgrade kits available
- 20' (6.1m) 1/4" (6mm) OD discharge hose included

### APPLICATIONS

- Designed for dispensing bottled water to coffee machines, beverage dispensers, vending machines and carts
- For remote locations where water supply is inaccessible

### SINGLE INLET BOTTLE WATER SYSTEM MODELS

MODEL #	VOLTAGE	PLUG
BW5000-000A	115V AC	US plug
BW5002-000A	230V AC	AU plug
BW5003-000A	115V AC	UK plug
BW5004-000A	230V AV	EU plug

### DUAL INLET BOTTLE WATER SYSTEM MODELS

MODEL #	VOLTAGE	PLUG
BW5020-000A	115V AC	US plug
BW5022-000A	230V AC	AU plug
BW5023-000A	115V AC	UK plug
BW5024-0004	230V AC	EU plug

## BevJet Compact & BevJet5000



### BEVJET COMPACT

- BevJet Compact is designed for use with bottled water application and has a bag-in-box dispense system for dispensing wine, juice, teas or liquor
- Senses when bottle/beverage box is empty and automatically shuts down
- Illuminated ON/OFF switch indicated when supply is depleted
- Compact design allows it to be mounted in tight spaces such as cabinets, carts and under counter applications

### BEVJET5000

- Bag-in-box dispense system is designed for dispensing wine, juice, teas or liquor
- Senses when beverage box is empty and automatically shuts down; restarts automatically when full supply is reconnected
- Enclosed pump unit is easy to clean, prevents contamination and minimizes noise

Both the BevJet Compact and BevJet5000 are NSF certified and have quick disconnect ports that allow for hose replacement within seconds.

### BEVJET COMPACT MODELS

MODEL #	VOLTAGE	PLUG	COMMENTS
BLC1011-000A	115V AC	US plug	
BLC2011-000A	230V AC	UK plug	
BLC3011-000A	230V AC	EU plug	
BLC4011-000A	230V AC	AU plug	
BLC5011-000A	100V-240V AC	No plug	
BLC1011-010A*	115V AC	US plug	
BLC2011-010A*	230V AC	UK plug	
BLC3011-010A*	230V AC	EU plug	
BLC4011-010A*	230V AC	AU plug	
BLC5011-010A*	100V-240V AC	No plug	
BLC1011-011A*	115V AC	US plug	Includes faucet
BLC2011-011A*	230V AC	UK plug	Includes faucet
BLC3011-011A*	230V AC	EU plug	Includes faucet
BLC4011-011A*	230V AC	AU plug	Includes faucet
BLC5011-011A*	100V-240V AC	No plug	Includes faucet

\* Includes cap for 5 gallon water bottle and 20' (6.1m) of 1/4" (6mm) tubing

### BEVJET 5000 MODELS

MODEL #	VOLTAGE	PLUG
BIB5000A	100V-240V AC, 50/60 Hz, 1.5A	US plug
BIB5002A	100V-240V AC, 50/60 Hz, 1.5A	AU plug
BIB5003A	100V-240V AC, 50/60 Hz, 1.5A	UK plug
BIB5004A	100V-240V AC, 50/60 Hz, 1.5A	EU plug
BIB5005A	12V DC, 1.2A	No plug

## Porta-Quick



## FOR INTERNATIONAL &amp; US MARKETS

The Porta-Quick™ portable oil changer makes quick, clean, and easy on-site oil changes using the vehicle's battery to power a reversible flexible impeller pump.

## FEATURES

- 14 quart (13L) container easily handles two engines
- Pump is reversible to both drain and refill engine oil
- Corrosion-resistant bronze pump head
- High-temperature-resistant Teflon™ dipstick probe
- Non-collapsible, thick-wall suction hose
- Garden hose thread adapter included for dipsticks with GHT male threaded ends
- Ignition protected - means it will not spark in the presence of fuel vapors

## MODELS

MODEL #	CE	VOLTAGE	AMP DRAW	FUSE SIZE
17800-2000	Yes	12V DC	7A	10A
17800-2024	Yes	24V DC	3.5A	5A

## SPECIFICATIONS

<b>VOLTAGE</b>	12V or 24V DC
<b>MOTOR</b>	Reversible with integral reversing switch
<b>BODY</b>	Bronze
<b>SEAL</b>	Lip type
<b>IMPELLER</b>	Nitrile
<b>CONTAINER</b>	Plastic with 14 quart (13.25 liter) capacity
<b>POWER CORD</b>	6' (2m) with alligator clips
<b>SUCTION HOSE</b>	4' (1.2m) of neoprene hose with 40" (1.2m) teflon dipstick probe
<b>DIMENSIONS</b>	15" high x 12-3/8" diameter (381mm x 314mm)
<b>WEIGHT</b>	9lb (4.1kg)

## Permanent Oil Changer



## FOR INTERNATIONAL &amp; US MARKETS

The Jabsco Oil Change system's manifold is factory-fitted with three ball valves to serve three different oil reservoirs, and may be fitted with two additional ball valves to drain up to five. The system can remove old oil from an engine or transmission, then be reversed with the built-in switch to pump new oil back into the engine or transmission. The system's cover provides an attractive appearance, fully shrouding the entire pump and manifold system. It also provides added protection against accidental draining of an engine's oil supply as it protects the valves from being accidentally left open. Additionally, at the end of an oil change, the cover will not close unless the valves are in the fully closed position.

## MODELS

MODEL #	CE	VOLTAGE	AMP DRAW	FUSE SIZE
17820-0012	Yes	12V DC	10A	15A
17820-0024	Yes	24V DC	5A	8A

## SPECIFICATIONS

<b>VOLTAGE</b>	12V or 24V DC
<b>MOTOR</b>	Reversible permanent magnet with integral reversing switch; complies with USCG 183.410 and ISO 8846 MARINE
<b>BODY</b>	Bronze
<b>SEAL</b>	Nitrile lip type
<b>IMPELLER</b>	Nitrile
<b>POWER CORD</b>	6' (2m) with alligator clips
<b>VALVES</b>	1/2" (13mm) NPT full flow ball type
<b>DIMENSIONS</b>	6-1/4" high x 10.9" long x 10.2" wide (159mm x 276mm x 259mm)
<b>WEIGHT</b>	9lb (4.1kg)

## Do-it-Yourself Oil Changer



## FOR INTERNATIONAL &amp; US MARKETS

The Do-It-Yourself Oil Changer is simple to use, and offers quick and easy operation for light-duty oil changes.

## FEATURES

- Great for lawn mowers, compactors, and other small-engine oil changes
- Fully assembled
- 14 quart (13L) container
- Tested to 1400 cycles
- 8' (2.5m) high temperature-resistant Teflon™ dipstick probe
- Uses the 12V power from your car or truck to operate a quiet diaphragm pump

## MODELS

MODEL #	CE	VOLTAGE	AMP DRAW	FUSE SIZE
17850-1012	Yes	12V DC	2A	5A

## SPECIFICATIONS

<b>MOTOR</b>	12V DC with integral power switch
<b>BODY</b>	Polypropylene
<b>DIAPHRAGM</b>	Buna/PP blend, oil resistant
<b>VALVES</b>	FKM, oil resistant
<b>CONTAINER</b>	Plastic with 3.5 gallon (13.2 liter) capacity bucket
<b>BATTERY LEADS</b>	6' (2m) with alligator clips
<b>SUCTION HOSE</b>	8' (2.5m) oil and heat resistant
<b>DIMENSIONS</b>	16" high x 12-3/8" diameter (406mm x 314mm)
<b>WEIGHT</b>	Empty - 6lb (2.7kg)

## Flat Tank Oil Changer



## FOR INTERNATIONAL &amp; US MARKETS

The Jabsco Flat Tank Oil Changer system simplifies the engine oil changing process. Ideal for changing engine oil in boats, RVs, and lawn and garden equipment. There is no need to worry about open containers causing spills when changing engine oils with the 3-1/2 gallon (13L) compact, self-contained unit, fitted with a self-priming diaphragm pump with an easy-pour spout for emptying. The flat tank design allows for easy storage in work boxes, sheds or in the garage. Easy to use, clean and efficient dipstick suction tube, battery clamp wire leads and on/off pump switch.

## FEATURES

- Stores easily
- Compact, robust tank design
- Easy-pour spout with screw-on cap
- Easy-to-carry handle
- 3-1/2 gallon (13L) sealed container
- Self-priming, run-dry pump
- Battery leads: 6' (2m) with alligator clips for easy connection to 12V car or truck battery
- Suction tube: 8' (2.4m), oil and heat-resistant
- Powerful 12V DC motor makes oil changing quick and simple

## MODELS

MODEL #	CE	VOLTAGE	AMP DRAW	FUSE SIZE
17860-0012	Yes	12V DC	4A	5A

## SPECIFICATIONS

<b>MOTOR</b>	Includes integral power switch
<b>VOLTAGE</b>	12V or 24V DC
<b>BODY</b>	Polypropylene
<b>DIAPHRAGM</b>	Buna/PP blend
<b>VALVES</b>	FKM
<b>CONTAINER</b>	Plastic with 14 quart (13.24 liter) capacity tank
<b>BATTERY LEADS</b>	7' (2.1m) with alligator clips
<b>SUCTION HOSE</b>	8' (2.4m) oil and heat resistant
<b>WEIGHT</b>	Empty - 6lb (2.7kg)

# Chemical Resistance Guide 10

Introduction  
Chemical Resistance Guide



# 10 Chemical Resistance Guide

## INTRODUCTION

### Introduction

This Chemical Resistance Guide is offered to assist in selecting pump materials that are most resistant to the chemicals that may be used with a Xylem pump. The information is based on Xylem laboratory tests, field testing programs, and general data from industry sources. It should be used only as a guide in the selection of pump materials. Suitability for the application should be determined by actual use and is the full responsibility of the customer. No warranty, expressed or implied, can be extended by Xylem where failure is caused by chemical attack on pump materials. Temperature, aeration, concentration, and other factors may change the effect of the specific fluid on the pump materials. Data shown is based on results at ambient temperatures, unless otherwise noted.

#### RATING SYSTEM

The "A" rating indicates little effect on the physical properties of the material (Generally Satisfactory).

The "B" rating indicates minor to moderate effect (Generally Satisfactory but Should be Qualified By Testing).

The "C" rating indicates a change in the physical properties in excess of acceptable tolerances could occur (Generally Not Satisfactory, Must be Qualified By Testing).

The "D" rating indicates rapid physical deterioration, swelling of check valves, or diaphragm, or chemical attack on the pump housing material (Not Satisfactory).

Where no rating is shown, data is not currently available, and pump materials should be qualified by testing.

It is recommended that the pump be thoroughly flushed with water or other neutralizing agent after each use whenever possible.

ELASTOMER	PROPERTIES	GENERAL CHEMICAL RESISTANCE	
		RESISTANT TO	ATTACKED BY
Buna-N	Excellent resistance to petroleum-based fluids. Good physical properties.	Many hydrocarbons, fats, oils, greases, hydraulic fluids, chemicals.	Ozone (except PVC blends), ketones, esters, aldehydes, chlorinated and nitro hydrocarbons.
EP/PP blend (Santoprene)	Resistant to a wide variety of solvents and chemicals. Excellent abrasion resistance and long mechanical flex life in hot and cold environments.	High polar fluids such as alcohols, ketones, glycols, esters, and aqueous solutions of acids, salts and bases.	Most hydrocarbons and petroleum- or oil-based products
EPDM	Excellent ozone, chemical, and aging resistance. Poor resistance to petroleum-based fluids.	Animal and vegetable oils, ozone, strong and oxidizing chemicals.	Mineral oils and solvents, aromatic hydrocarbons.
FFKM (Kalrez)	Excellent chemical resistance. Excellent high and low temperature properties.		
FKM (Viton)	Excellent oil and air resistance both at low and high temperatures. Very good chemical resistance.	All aliphatic, aromatic and halogenated hydrocarbons, acids, animal and vegetable oils.	Ketones, low molecular weight esters and nitro-containing compounds, and nitro hydrocarbons.
Fluoro-silicone	Moderate or oxidizing chemicals, ozone, aromatic chlorinated solvents, bases.	Brake fluids, hydrazine, ketones.	
Natural rubber	Excellent physical properties including abrasion and low temperature resistance. Poor resistance to petroleum-based fluids.	Most moderate chemicals, wet or dry, organic acids, alcohols, ketones, aldehydes and alkalies.	Ozone, strong acids, fats, oils, greases, most hydrocarbons including benzene, toluene, gasoline, and lubricating oils.
Neoprene	Good weathering resistance. Flame retarding. Moderate resistance to petroleum-based fluids.	Moderate chemicals and acids, ozone, oils, fats, greases, many oils and solvents.	Strong oxidizing acids, esters, ketones, chlorinated, aromatic and nitro hydrocarbons.
Silicone	Excellent high and low temperature properties. Fair physical properties.	Moderate or oxidizing chemicals, ozone, concentrated sodium hydroxide.	Many solvents, oils, concentrated acids, dilute sodium hydroxide.



#### GAS WARNING

No pump manufactured by Xylem should be used for gasoline or any fluid with a flash point below 100°F (38°C).